

MARYLAND  
GEOLOGICAL  
SURVEY

VOL.V  
1905

MARYLAND  
GEOLOGICAL SURVEY



Ref. #1656

**MGS LIBRARY**

MGS LIBRARY

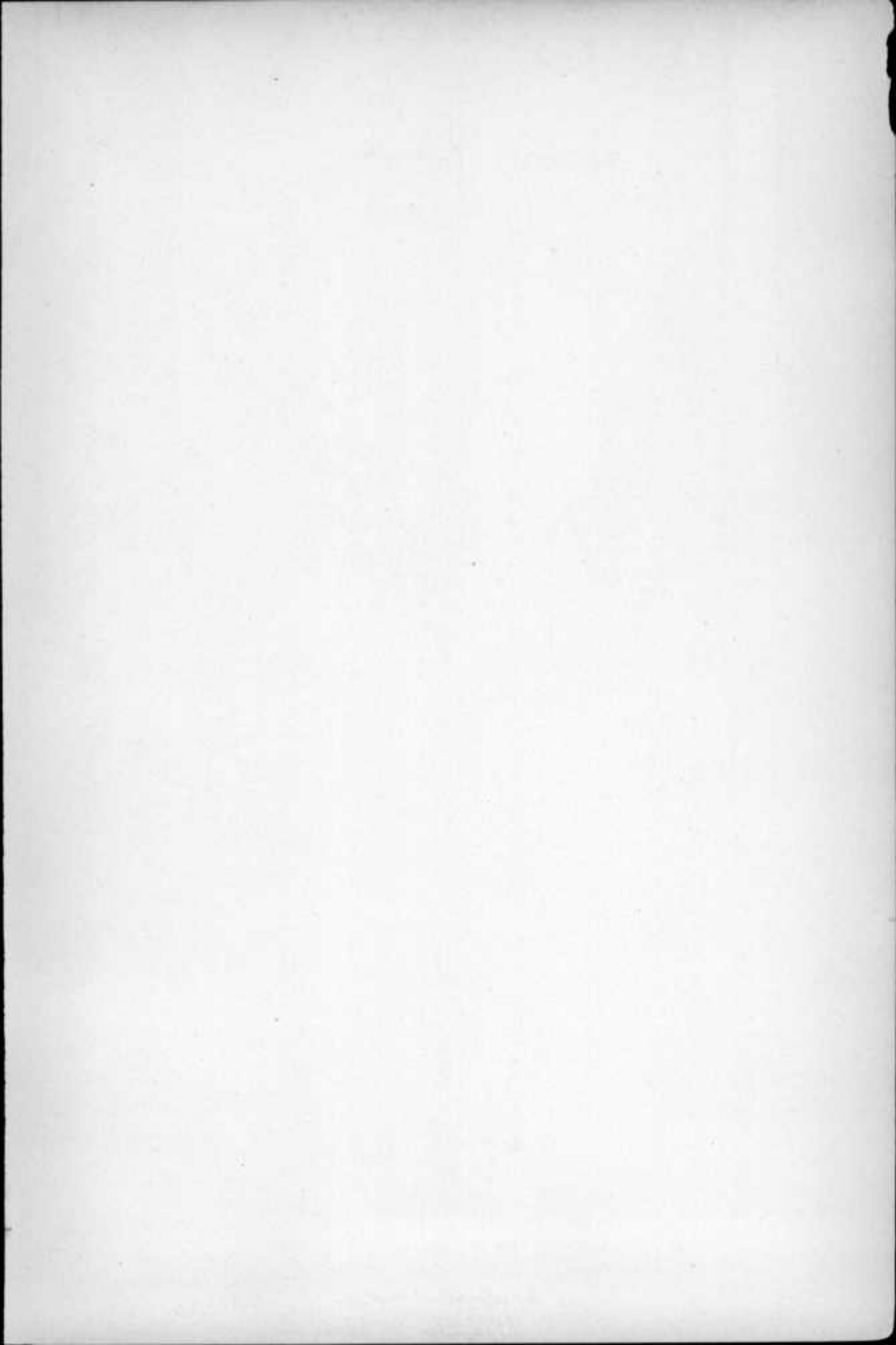



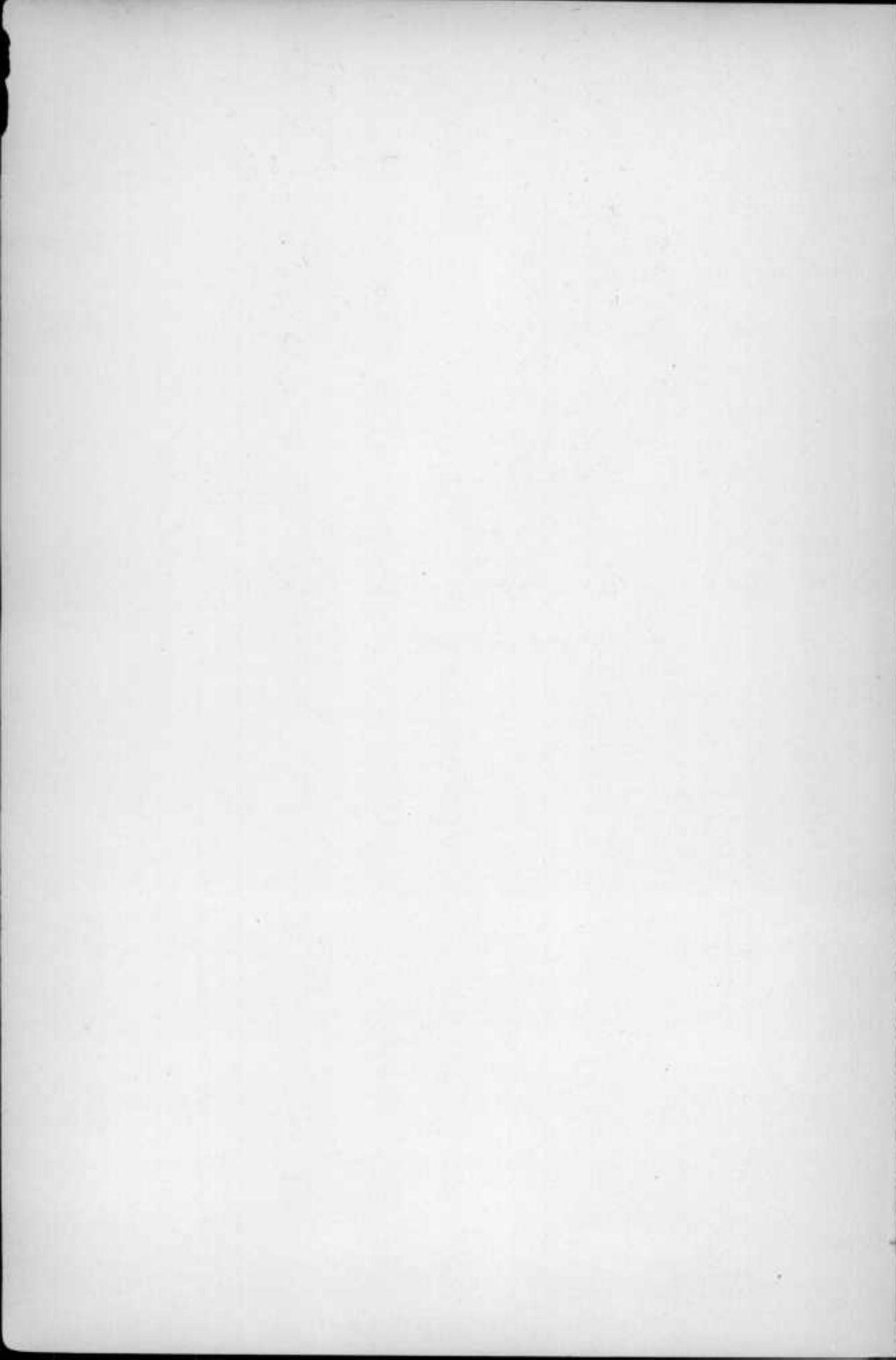

MARYLAND GEOLOGICAL SURVEY

VOLUME FIVE

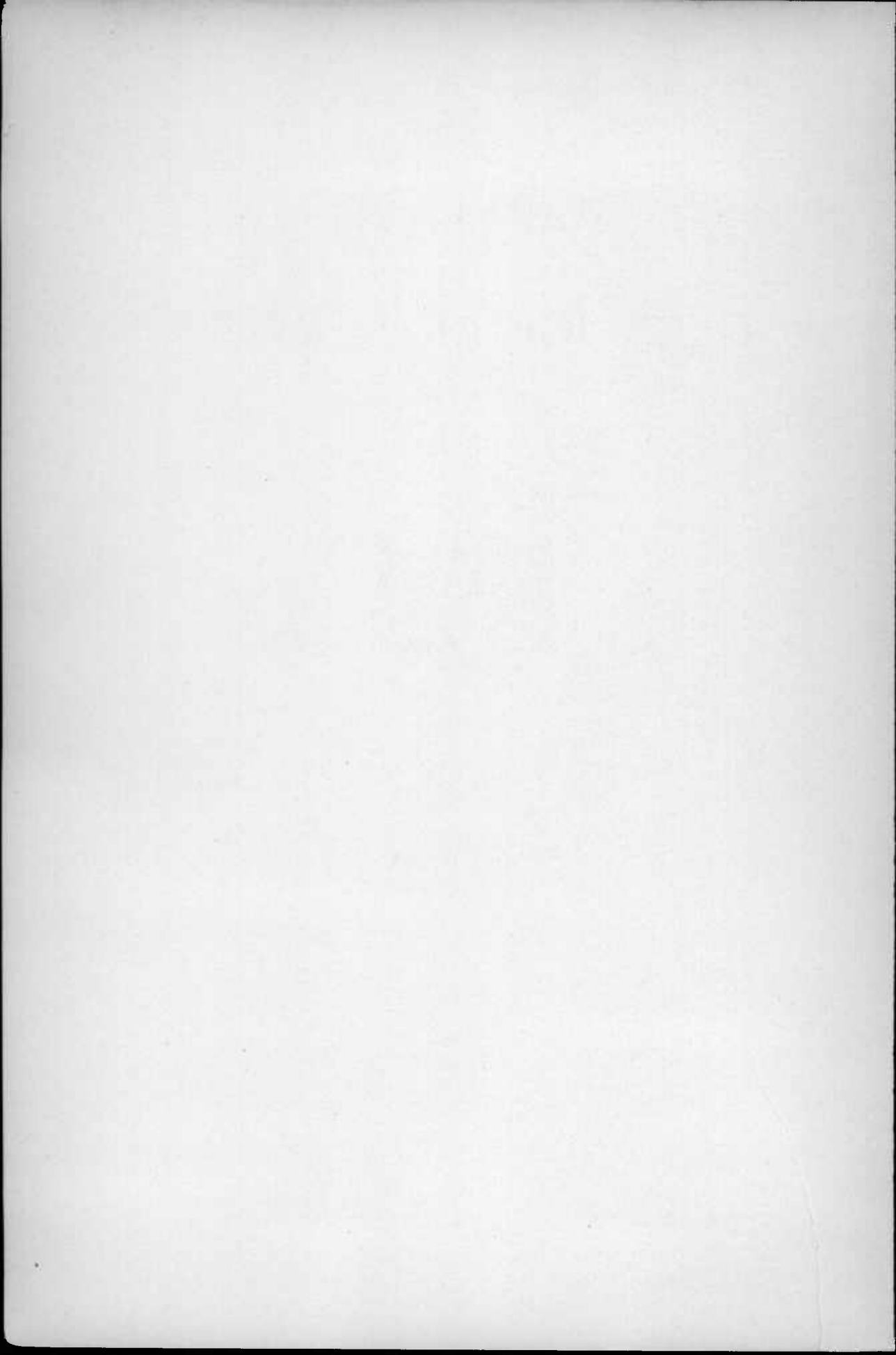

MARYLAND  
GEOLOGICAL SURVEY



VOLUME FIVE

BALTIMORE  
THE JOHNS HOPKINS PRESS  
1905



*The Friedenwald Company*  
BALTIMORE, MD., U. S. A.

## COMMISSION

EDWIN WARFIELD, . . . . . PRESIDENT.  
GOVERNOR OF MARYLAND.

GORDON T. ATKINSON, . . . . .  
COMPTROLLER OF MARYLAND.

IRA REMSEN, . . . . . EXECUTIVE OFFICER.  
PRESIDENT OF THE JOHNS HOPKINS UNIVERSITY.

R. W. SILVESTER, . . . . . SECRETARY.  
PRESIDENT OF THE MARYLAND AGRICULTURAL COLLEGE.

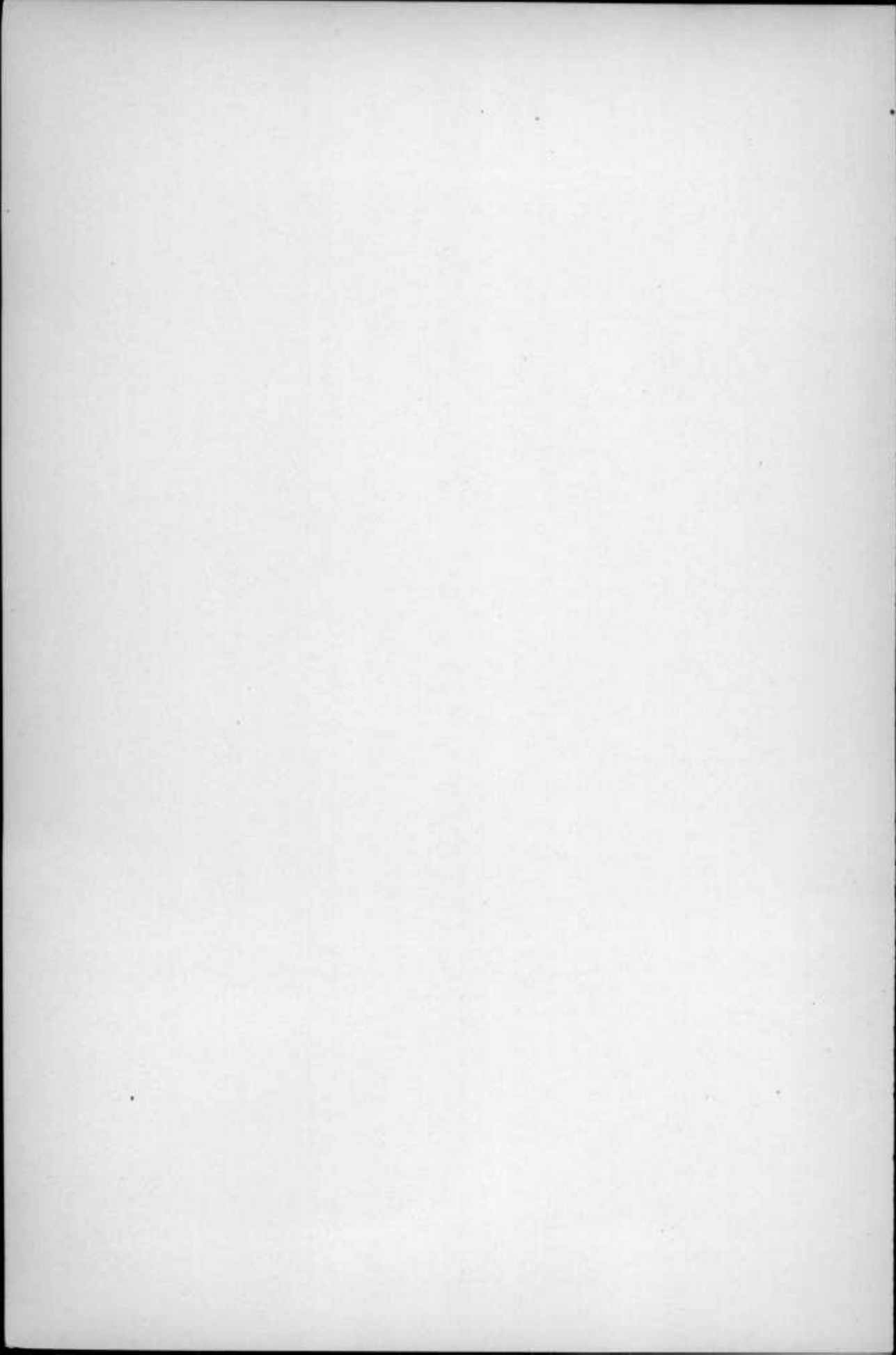

## SCIENTIFIC STAFF

WM. BULLOCK CLARK, . . . . . STATE GEOLOGIST.  
SUPERINTENDENT OF THE SURVEY.

---

EDWARD B. MATHEWS, . . . . . ASSISTANT STATE GEOLOGIST.

GEORGE C. MARTIN, . . . . . GEOLOGIST.

GEORGE B. SHATTUCK, . . . . . GEOLOGIST.

B. L. MILLER, . . . . . GEOLOGIST.

C. K. SWARTZ, . . . . . GEOLOGIST.

---

WALTER W. CROSBY, . . . . .  
CHIEF ENGINEER OF THE HIGHWAY DIVISION.

L. A. BAUER, . . . . .  
CHIEF OF DIVISION OF TERRESTRIAL MAGNETISM.

And with the cooperation of several members of the scientific  
bureaus of the National Government.



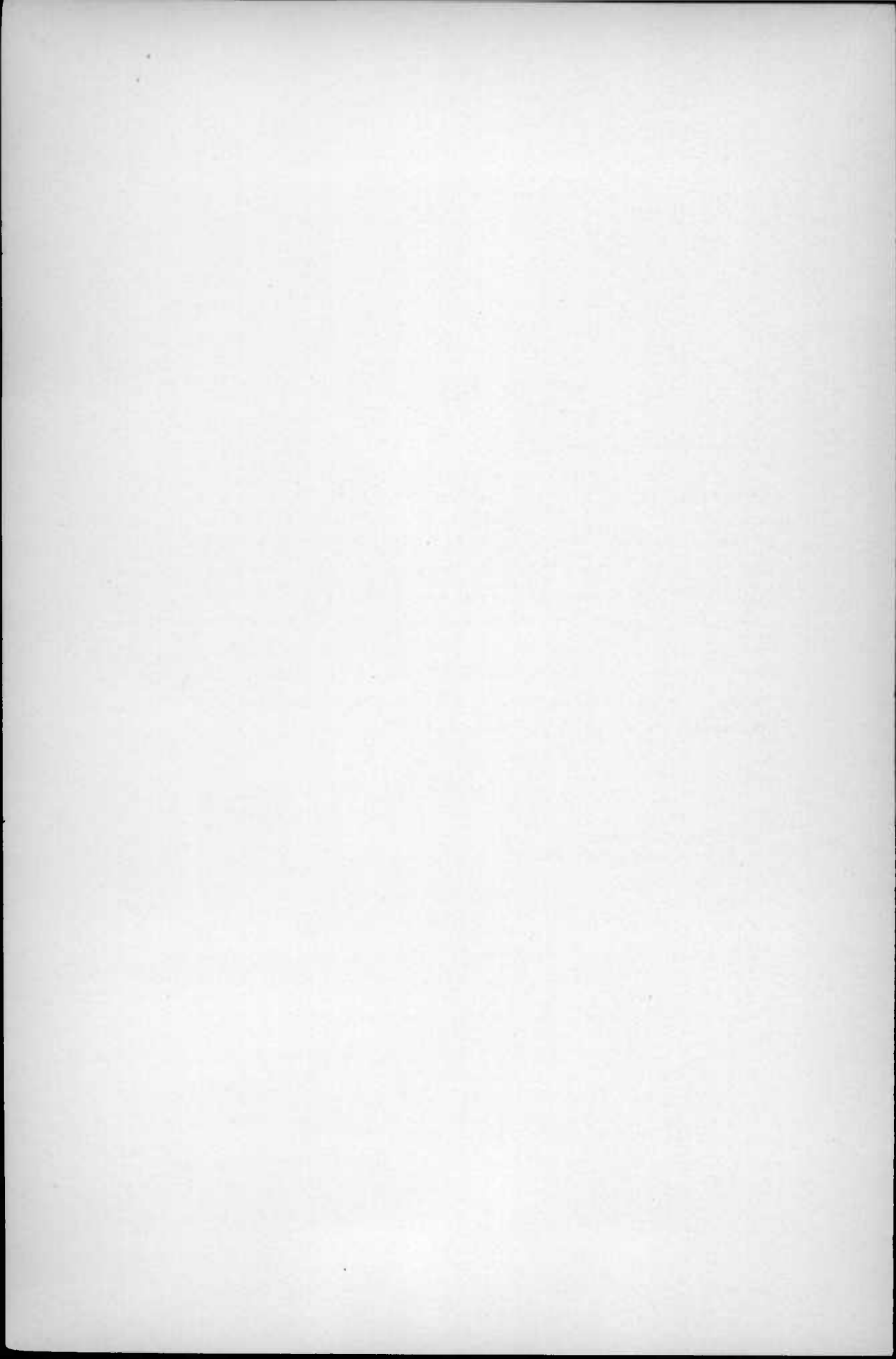

## LETTER OF TRANSMITTAL

To His Excellency EDWIN WARFIELD,  
Governor of Maryland and President of the Geological Survey  
Commission.

*Sir:*—I have the honor to present herewith the fifth volume of the general reports of the Maryland Geological Survey. The several articles contain information of value regarding a variety of subjects which I feel confident will prove of assistance in the development of the mineral resources of the State. The elaborate report dealing with the coal deposits has been in preparation for several years and represents a careful examination of the character and distribution of the several coal seams of the State. I am,

Very respectfully,

WILLIAM BULLOCK CLARK,  
*State Geologist.*

JOHNS HOPKINS UNIVERSITY,  
BALTIMORE, *December, 1905.*

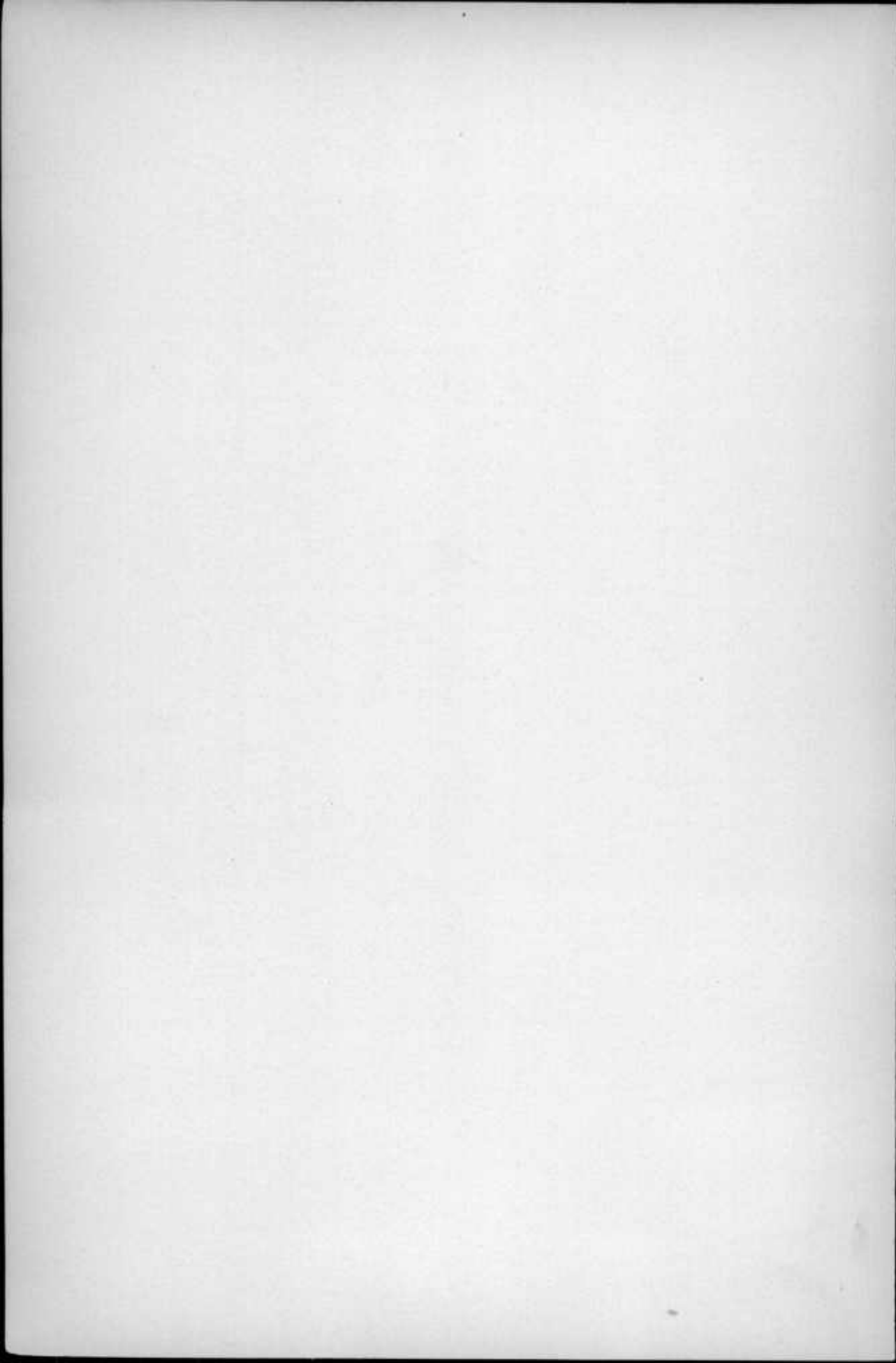

# CONTENTS

	PAGE
PREFACE .....	19
PART I. SECOND REPORT ON MAGNETIC WORK IN MARYLAND.	
By L. A. BAUER .....	23
INTRODUCTION .....	25
THE DISTRIBUTION OF THE MAGNETIC DECLINATION IN MARYLAND FOR JANUARY 1, 1900 .....	28
Explanatory Remarks on the Methods of Observing and Reducing..	28
The Accuracy of the Observations .....	29
Additional Secular Variation Data of the Magnetic Declination ....	42
Map of the Lines of Equal Magnetic Declination for January 1, 1900.	44
DESCRIPTION OF MAGNETIC STATIONS IN MARYLAND .....	45
Magnetic Stations in Maryland between 1896 and 1901 .....	45
Western Boundary of Maryland Stations of 1897, along the "Fairfax" Meridian Line .....	60
Western Boundary of Maryland Stations of 1897, along the "Potomac" Meridian Line .....	60
DESCRIPTION OF RECENT MAGNETIC STATIONS IN THE VICINITY OF MARYLAND OCCUPIED BY THE U. S. COAST AND GEODETIC SURVEY .....	61
Delaware .....	61
Virginia .....	61
West Virginia .....	63
THE DISTRIBUTION OF THE MAGNETIC INCLINATION OR DIP FOR JANUARY 1, 1900 .....	64
Explanatory Remarks as to Isoclinic Map, Methods of Observing and Reducing .....	64
Accuracy of the Observations .....	72
Tables .....	74
THE DISTRIBUTION OF THE HORIZONTAL INTENSITY OF THE EARTH'S MAGNETIC FORCE FOR JANUARY 1, 1900.....	78
Method of Observation .....	78
Reduction to January 1, 1900 .....	80
The Accuracy of the Observations .....	81
Tables .....	82
Map of the Lines of Equal Horizontal Intensity for January 1, 1900..	89
THE MAGNETIC ELEMENTS AND COMPONENTS IN MARYLAND FOR JANUARY 1, 1900 .....	89
Preliminary attempt at an analysis of the Terrestrial Magnetic Field in Maryland .....	96

	PAGE
PART II. FINAL REPORT ON THE SURVEY OF THE BOUNDARY LINE BETWEEN ALLEGANY AND GARRETT COUNTIES. By L. A. BAUER .....	99
INTRODUCTION .....	101
PREVIOUS ATTEMPTS AT A DETERMINATION OF THE BOUNDARY LINE.....	105
Chisholm's Line .....	105
Harned's Line .....	106
THE PROBLEM STATED .....	107
Trial Line Method .....	107
Latitude and Longitude Method .....	109
Triangulation Method .....	110
A "Straight" Line on the Earth's Surface.....	111
THE TRIANGULATION .....	114
Geodetic Coordinates of Triangulation Stations.....	117
TRACING THE TRIAL LINE .....	120
THE TERMINAL POINTS .....	122
Determination of "Middle of Mouth of Savage River" .....	123
Determination of Terminal Point of entire Boundary Line .....	125
The Initial Point of the Line .....	126
THE MARKING OF THE BOUNDARY LINE .....	128
The Manner of Marking .....	128
Location of the Mounds .....	129
MAGNETIC WORK DONE IN CONNECTION WITH THE BOUNDARY LINE.....	133
Additional Magnetic Data .....	137
COURSES AND DISTANCES.....	137
MISCELLANEOUS FIELD NOTES .....	139
Length of Boundary Line .....	140
Azimuth of Boundary Line .....	140
Latitudes and Longitudes .....	141
PART III. THIRD REPORT ON THE HIGHWAYS OF MARYLAND. By A. N. JOHNSON .....	143
INTRODUCTION .....	145
ROAD ADMINISTRATION .....	148
Outline of a Suggested County Road Law .....	149
STATISTICS .....	152
Mileage .....	152
Road Machinery .....	152
Summary of County Road Expenditures .....	153

	PAGE
OPERATIONS DURING 1902 AND 1903 .....	159
Field Work .....	160
Specifications .....	161
Special Road Improvement .....	162
Allegany County .....	162
National Road .....	162
Bedford Road .....	164
Baltimore County .....	165
Garrison Road .....	165
Stevenson Station Road .....	166
Hamilton Avenue .....	166
Eastern Avenue .....	166
Seminary Avenue .....	167
Park Heights Avenue .....	168
Joppa Road .....	168
Hillen Road .....	169
Sherwood Bridge .....	169
Green Spring Avenue .....	169
Park Heights Avenue Extension .....	170
Cecil County .....	170
Rising Sun-Farmington Road .....	170
Elkton-Blue Ball Road .....	172
Garrett County .....	172
Oakland-Mt. Lake Park Road .....	172
Harford County .....	173
Belair-Churchville Road .....	173
Churchville-Havre de Grace Road .....	173
Forest Hill Road .....	174
Fallston Road .....	174
Howard County .....	174
Hollofield Road .....	175
Old Frederick Road, Brown's Hill .....	176
River Road .....	176
Washington and Baltimore Road .....	176
Upper Sykesville Road .....	177
Hood's Mill Road .....	178
Tobacco House Hill Road .....	179
Rockburn Branch Road .....	179
Montgomery County .....	179
Dickerson Road .....	179

	PAGE
Prince George's County .....	180
Riggs Road .....	181
Washington and Baltimore Road .....	182
T B Road .....	182
Central Avenue .....	183
Chesapeake Junction Road .....	184
Queen Anne's County .....	184
Centerville-Chestertown Road .....	184
St. Mary's County .....	186
Leonardtown Square .....	186
LABORATORY WORK .....	187
Tests of Macadam Materials .....	187
Paving Brick Tests .....	190
Rattler Tests .....	191
Rattler Tests with Cast Iron and Steel Shot.....	191
Cement Tests .....	194
Tests of Concrete Bars .....	194
Tensile Strength of Cement .....	195
Wearing Test of Stone and Brick .....	199
SAMPLE FORM FOR SPECIFICATION BLANK .....	203
PART IV. REPORT ON THE COALS OF MARYLAND. BY WM BULLOCK CLARK, with the collaboration of GEORGE C. MARTIN, J. J. RUTLEDGE, B. S. RANDOLPH, N. ALLEN STOCKTON, W. B. D. PENNIMAN, AND ARTHUR L. BROWNE.....	219
PART IVa. ORIGIN, DISTRIBUTION, AND USES OF COAL. BY WM. BULLOCK CLARK .....	221
INTRODUCTION .....	221
HISTORY OF THE USE OF COAL.....	222
ORIGIN OF COAL.....	224
GEOLOGICAL AGE OF COAL.....	227
DISTRIBUTION AND PRODUCTION OF COAL.....	228
THE APPALACHIAN COAL FIELD.....	232
CHARACTER OF COAL AND ITS USES.....	238
PART IVb. THE GEOLOGY OF THE MARYLAND COAL DISTRICT. BY GEO. C. MARTIN.....	241
STRATIGRAPHY OF THE MARYLAND COAL MEASURES.....	241
INTRODUCTORY .....	241
THE POTTSVILLE FORMATION.....	244

	PAGE
THE ALLEGHENY FORMATION.....	246
THE CONEMAUGH FORMATION.....	251
THE MONONGAHELA FORMATION.....	255
THE DUNKARD FORMATION.....	258
GEOLOGICAL STRUCTURE OF THE MARYLAND COAL MEASURES.....	259
THE GEORGES CREEK-POTOMAC SYNCLINE.....	260
Position .....	260
Attitude of the Strata.....	264
General Features .....	265
THE DEER PARK ANTICLINE.....	265
THE CASTLEMAN SYNCLINE.....	265
Position .....	265
Attitude of the Strata.....	266
General Features .....	267
THE UPPER YOUGHIOGHENY SYNCLINE.....	267
Position .....	267
Attitude of the Strata .....	268
General Features .....	269
THE ACCIDENT ANTICLINE.....	269
Position .....	269
THE CRANESVILLE ANTICLINE.....	269
Position .....	269
THE LOWER YOUGHIOGHENY SYNCLINE.....	270
Position .....	270
Attitude of the Strata.....	270
General Features .....	271
CONCLUSIONS .....	271
THE GEOLOGICAL HISTORY OF THE MARYLAND COAL MEASURES.....	274
EARLY PALEOZOIC PERIODS.....	274
EARLY CARBONIFEROUS OR MISSISSIPPIAN PERIOD.....	275
The Pocono Epoch.....	275
The Greenbrier Epoch.....	277
The Mauch Chunk Epoch.....	278
LATER CARBONIFEROUS OR PENNSYLVANIAN PERIOD.....	278
The Pottsville Epoch.....	279
The Allegheny Epoch.....	281
The Conemaugh Epoch.....	283
The Monongahela Epoch.....	287
THE PERMIAN PERIOD .....	289
The Dunkard Epoch.....	289



	PAGE
THE MESOZOIC AND CENOZOIC ERAS.....	289
The Pre-Quaternary Periods.....	289
The Quaternary Period .....	290
SUBSEQUENT HISTORY .....	290
 PART IVc. CORRELATION OF THE FORMATIONS AND MEMBERS.	
By WM. BULLOCK CLARK AND GEO. C. MARTIN.....	291
POTTSVILLE FORMATION .....	293
COMPOSITION AND RELATIONS.....	293
BASAL CONTACT (1).....	294
SHARON SANDSTONE (2).....	295
SHARON COAL (3).....	295
LOWER CONNOQUENESSING SANDSTONE (4).....	295
QUAKERTOWN COAL (5).....	295
UPPER CONNOQUENESSING SANDSTONE (6).....	295
LOWER MERCER COAL (7).....	296
MOUNT SAVAOG FIRECLAY (8).....	296
MOUNT SAVAOG OR UPPER MERCER COAL (9).....	296
HOMEWOOD SANDSTONE (10).....	296
ALLECHENY FORMATION .....	297
COMPOSITION AND RELATIONS.....	297
BROOKVILLE COAL (11).....	298
CLARION COAL (12).....	298
CLARION SANDSTONE (13).....	298
VANPORT OR FERRIFEROUS LIMESTONE (14).....	298
KITTANNING SANDSTONE (15).....	299
" SPLIT-SIX " COAL (16).....	299
LOWER KITTANNING COAL (17).....	299
MIDDLE KITTANNING COAL (18), " SIX-FOOT " OR DAVIS.....	299
UPPER KITTANNING COAL (19).....	299
LOWER FREEPORT SANDSTONE (20).....	300
LOWER FREEPORT LIMESTONE (21).....	300
LOWER FREEPORT COAL (22).....	300
UPPER FREEPORT OR ROARING CREEK COAL (23).....	300
UPPER FREEPORT LIMESTONE AND BOLIVAR FIRECLAY (24).....	300
UPPER FREEPORT COAL (25).....	300
CONEMAUGH FORMATION .....	301
COMPOSITION AND RELATIONS .....	301
LOWER MAHONING SANDSTONE (26).....	301

	PAGE
MAHONING LIMESTONE (27).....	301
MAHONING COAL (28).....	303
UPPER MAHONING SANDSTONE (29).....	303
BRUSH CREEK COAL (30).....	303
LOWER CAMBRIDGE LIMESTONE (31).....	304
BUFFALO SANDSTONE (32).....	304
GRANTSVILLE ("BEACHY") COAL.....	304
UPPER CAMBRIDGE LIMESTONE (33).....	305
LOWER RED SHALES.....	305
BAKERSTOWN COAL (34).....	305
SALTSBURG SANDSTONE (35).....	305
MAYNADIER COAL.....	306
FRIENDSVILLE COAL.....	306
AMES OR CRINOIDAL COAL (37).....	307
ELKCLICK COAL (38).....	307
MORGANTOWN SANDSTONE (39).....	307
LONACONING COAL.....	307
CLARKSBURG LIMESTONE (40).....	307
FRANKLIN OR LITTLE CLARKSBURG (41).....	308
CONNELLSVILLE SANDSTONE (42).....	308
LOWER PITTSBURG LIMESTONE (43).....	308
LOWER PITTSBURG COALS (44).....	308
MONONGAHELA FORMATION.....	308
COMPOSITION AND RELATIONS.....	308
PITTSBURG COAL (45).....	310
REDSTONE LIMESTONE (46).....	310
REDSTONE COAL (47).....	310
SEWICKLEY LIMESTONE (48).....	311
LOWER SEWICKLEY COAL (49).....	311
UPPER SEWICKLEY OR TYSON COAL (50).....	311
SEWICKLEY SANDSTONE (51).....	311
UNIONTOWN COAL (52).....	312
UNIONTOWN SANDSTONE (53).....	312
WAYNESBURG LIMESTONE (54).....	312
WAYNESBURG COAL (55).....	312
DUNKARD FORMATION.....	312
COMPOSITION AND RELATIONS.....	312
WAYNESBURG SANDSTONE (56).....	314

	PAGE
WAYNESBURG "A" COAL (57).....	314
WASHINGTON COAL (58).....	314
UPPER WASHINGTON LIMESTONE (59).....	314
JOLLYTOWN COAL (60).....	314
JOLLYTOWN LIMESTONE (61).....	314
CONCLUSIONS .....	315
PART IVd. DISTRIBUTION AND CHARACTER OF THE MARYLAND COAL BEDS. By WM. BULLOCK CLARK, GEO. C. MARTIN, AND J. J.	
RUTLEDGE .....	317
GENERAL RELATIONS .....	317
THE GEORGES CREEK BASIN.....	321
THE POTTSVILLE COALS OF THE GEORGES CREEK BASIN.....	323
Sharon Coal .....	323
Quakertown Coal .....	324
Mount Savage or Upper Mercer Coal.....	324
THE ALLEGHENY COALS OF THE GEORGES CREEK BASIN.....	326
Brookville (Bluebaugh) Coal .....	329
Clarion (Parker) Coal.....	331
"Split-six" Coal .....	333
Lower (and Middle) Kittanning (Davis or "Six-foot") Coal.....	334
Upper Kittanning Coal.....	339
Lower Freeport Coal.....	340
Upper Freeport (Thomas or "Three-foot") Coal.....	341
THE CONEMAUGH COALS OF THE GEORGES CREEK BASIN.....	344
Mahoning Coal .....	344
Brush Creek (Masontown) Coal.....	345
Bakerstown (Barton or "Four-foot") Coal.....	350
Friendsville (Crinoidal) Coal.....	368
Elklick Coal .....	369
Lonaconing Coal .....	369
Franklin (Little Clarksburg or "Dirty nine-foot") Coal.....	371
Little Pittsburg Coal .....	376
THE MONONGAHELA COALS OF THE GEORGES CREEK BASIN.....	379
Pittsburg (Elkgarden, "Fourteen-foot" or "Big Vein") Coal....	380
Redstone Coal .....	399
Lower Sewickley Coal .....	399
Upper Sewickley (Tyson) Coal.....	399
Uniontown Coal .....	404
Waynesburg (Koontz) Coal .....	404
THE DUNKARD COALS OF THE GEORGES CREEK BASIN.....	406
Washington Coal .....	406

	PAGE
THE POTOMAC BASIN .....	407
THE POTTSVILLE COALS OF THE POTOMAC BASIN.....	408
THE ALLEGHENY COALS OF THE POTOMAC BASIN.....	409
Brookville (Bluebaugh) Coal .....	409
Clarion Coal .....	409
Lower (and Middle) Kittanning (Davis or "Six-foot") Coal.....	413
Upper Kittanning Coal.....	429
Lower Freeport Coal.....	431
Upper Freeport (Thomas or "Three-foot") Coal.....	432
THE CONEMAUGH COALS OF THE POTOMAC BASIN.....	438
Mahoning Coal .....	438
Brush Creek (Masontown) Coal.....	439
Bakerstown (Barton or "Four-foot") Coal.....	440
Friendsville (Crinoidal) Coal.....	448
Other Coals .....	449
THE MONONGAHELA COALS OF THE POTOMAC BASIN.....	449
THE CASTLEMAN BASIN.....	452
THE POTTSVILLE COALS OF THE CASTLEMAN BASIN.....	452
Mount Savage Coal.....	453
THE ALLEGHENY COALS OF THE CASTLEMAN BASIN.....	453
Brookville (Bluebaugh) Coal.....	455
Clarion (Parker) Coal.....	455
Lower (and Middle) Kittanning (Bender) Coal.....	456
Lower Freeport Coal.....	459
Upper Freeport Coal.....	460
THE CONEMAUGH COALS OF THE CASTLEMAN BASIN.....	461
Mahoning Coal .....	462
Brush Creek (Masontown) Coal.....	463
Grantsville (Beachy) Coal.....	463
Bakerstown (Honeycomb) Coal .....	468
Maynadier Coal .....	474
Friendsville (Crinoidal) Coal.....	475
Other Coals .....	477
THE UPPER YOUGHIOGHENY BASIN.....	477
THE POTTSVILLE COALS OF THE UPPER YOUGHIOGHENY BASIN.....	477
Mt. Savage (Upper Mercer) Coal.....	478
THE ALLEGHENY COALS OF THE UPPER YOUGHIOGHENY BASIN.....	479
Clarion Coal .....	479
Lower (and Middle) Kittanning Coal.....	480
Lower Freeport Coal.....	489
Upper Freeport ("Sandrock") Coal.....	491

	PAGE
THE CONEMAUGH COALS OF THE UPPER YOUGHIOGHENY BASIN.....	493
Bakerstown Coal .....	494
THE LOWER YOUGHIOGHENY BASIN.....	494
THE POTTSVILLE COALS OF THE LOWER YOUGHIOGHENY BASIN.....	496
THE ALLEGHENY COALS OF THE LOWER YOUGHIOGHENY BASIN.....	496
"Split-six" Coal .....	496
Lower (and Middle) Kittanning ("White Rock" or "Four-foot") Coal .....	497
Lower Freeport Coal.....	503
Upper Freeport ("Sandrock" or "Four-foot") Coal.....	504
THE CONEMAUGH COALS OF THE LOWER YOUGHIOGHENY BASIN.....	506
Mahoning Coal .....	507
Brush Creek Coal .....	509
Bakerstown Coal .....	510
Friendsville (Crinoidal) Coal.....	510
Franklin (Little Clarksburg) Coal.....	511
Little Pittsburg Coal.....	511
PART IVe. HISTORY OF THE MARYLAND COAL REGION. By B. S.	
RANDOLPH .....	513
LABOR .....	523
PART IVf. THE COAL MINES OF MARYLAND. By N. ALLEN STOCK-	
TON .....	529
INTRODUCTORY .....	529
THE GEORGES CREEK-UPPER POTOMAC BASIN.....	529
THE PITTSBURG SEAM OR "BIG VEIN".....	530
THICKNESS OF THE "BIG VEIN".....	531
WORKING THE "BIG VEIN" COAL BED.....	532
ROOF COAL, PROPS, ETC.....	534
"BREAK-THROUGHS" .....	535
LIFTING BOTTOMS .....	535
DRAWING PILLARS .....	536
CULLING THE COAL .....	539
WIRE-ROPE HAULAGE .....	542
ANOTHER METHOD OF UNDERGROUND HAULAGE.....	543
MINE TRACKS .....	544
VENTILATION .....	545
GASES .....	548

	PAGE
LIGHT .....	549
DRAINAGE .....	549
METHOD OF CONVEYING THE COAL FROM THE MINES TO THE TIPPLES.....	551
SIGNALS .....	552
TIPPLES .....	553
MINE CARS .....	556
IRREGULARITIES OF THE "BIG VEIN".....	557
CLEAVAGE PLANES .....	558
"SMALL VEINS" .....	558
COAL OPERATIONS .....	560
THE CONSOLIDATION COAL COMPANY.....	561
THE UNION MINING COMPANY AND COMPANIES ASSOCIATED WITH IT....	573
THE GEORGES CREEK COAL AND IRON COMPANY.....	577
THE MARYLAND COAL COMPANY.....	586
THE AMERICAN COAL COMPANY.....	589
THE NEW CENTRAL COAL COMPANY.....	591
THE CUMBERLAND BASIN COAL COMPANY.....	593
THE GEORGES CREEK AND BALD KNOB COAL COMPANY.....	594
THE BORDEN MINING COMPANY.....	595
THE BRADDOCK COAL COMPANY.....	595
THE FROSTBURG COAL MINING COMPANY .....	596
THE CHAPMAN COAL COMPANY.....	598
THE PIEDMONT AND GEORGES CREEK COAL COMPANY .....	598
THE MIDLAND MINING COMPANY.....	599
THE PHOENIX AND GEORGES CREEK MINING COMPANY .....	600
THE PIEDMONT-CUMBERLAND COAL COMPANY.....	601
THE MOSCOW-GEORGES CREEK MINING COMPANY.....	601
THE CUMBERLAND-GEORGES CREEK COAL COMPANY.....	603
THE PIEDMONT MINING COMPANY.....	604
THE LONACONING COAL COMPANY.....	604
THE COROMANDEL COAL COMPANY.....	606
G. C. PATTISON'S MINES.....	606
THE MONROE COAL MINING COMPANY.....	607
THE UPPER POTOMAC MINING COMPANY.....	610
THE DATESMAN COAL COMPANY.....	610
THE STOYER RUN COAL COMPANY.....	611
THE BLAINE MINING COMPANY AND GARRETT COUNTY COAL AND MINING COMPANY .....	611
THE DAVIS COAL AND COKE COMPANY.....	614

	PAGE
PART IVg. THE CHEMICAL AND HEAT-PRODUCING PROPERTIES OF MARYLAND COALS. By W. B. D. PENNIMAN and ARTHUR L. BROWNE .....	619
INTRODUCTORY .....	619
PREPARATION OF SAMPLES .....	619
ANALYSES .....	620
PROXIMATE ANALYSES .....	621
ULTIMATE ANALYSES .....	622
CALORIFIC OR HEATING VALUES .....	622
EXAMINATION OF THE ASH .....	625
RESULTS .....	625
TABLES OF ANALYSES OF MARYLAND COALS .....	628
INDEX .....	637

## ILLUSTRATIONS

PLATE	FACING PAGE
I. Eight-inch Theodolite .....	25
II. Map of Lines of Equal Magnetic Declination for Maryland.....	44
III. Map of Equal Magnetic Declination for Gaithersburg.....	44
IV. Map of Lines of Equal Magnetic Inclination for Maryland....	64
V. Map of Lines of Equal Horizontal Intensity.....	90
VI. Fig. 1.—Mound on Mason and Dixon Line.....	112
Fig. 2.—Mound on National Road.....	112
VII. Map of Boundary Line between Allegany and Garrett Counties.	120
VIII. Fig. 1.—Confluence of Savage River and North Branch of the Potomac .....	128
Fig. 2.—Triangulation Station (M <sub>1</sub> ).....	128
IX. Fig. 1.—Eastern Avenue, Baltimore County, Macadam Road with Trap-rock Top and Slag Foundation.....	166
Fig. 2.—Rising Sun-Farmington Road, Cecil County, Macadam Road, all Courses made of Trap-rock.....	166
X. Fig. 1.—Belair-Churchville Road, Harford County, Finishing a Macadam Road .....	174
Fig. 2.—Chestertown-Centerville Road, Queen Anne's County..	174
XI. Roads Built under Plans of Maryland Geological Survey.....	182
Fig. 1.—T B Road, Prince George's County, Deep Cut made to Reduce the Grade of Wilson's Hill.....	182
Fig. 2.—T B Road, Prince George's County, Concrete Culvert and Embankment at the Foot of Wilson's Hill.....	182
XII. Hydraulic Cement Testing Machine.....	198
Fig. 1.—Machine with Cement Ring in Position ready for a Test .....	198
Fig. 2.—Machine after a Test with the Top Cap removed....	198
XIII. Map showing the Distribution of Coal Measures of Maryland..	221
XIV. Map showing the Distribution of the Coal Fields of the United States .....	230
XV. Map showing the Northern Appalachian Coal Field.....	238
XVI. Views of Pottsville Formation.....	244
Fig. 1.—Lower Sharon Coal and Sandstone, near Western- port, Allegany County.	
Fig. 2.—Upper Connoquenessing Sandstone, Swallow Falls, Garrett County.	



PLATE	FACINO PAGE
XVII. Views of Allegheny Formation.....	250
Fig. 1.—Clarion Sandstone, near Windom, Garrett County.	
Fig. 2.—Lower Kittanning Coal and Sandstone, near Barnum, W. Va., Garrett County.	
XVIII. Views of Conemaugh Formation.....	254
Fig. 1.—Franklin Coal, near Lonaconing, Allegany County.	
Fig. 2.—Morgantown Sandstone, near Lonaconing, Allegany County.	
XIX. Views of Monongahela Formation.....	256
Fig. 1.—Knob with Bench at Pottsville Seam Horizon, one mile south of Barnum, W. Va., Garrett County.	
Fig. 2.—View of "Big Vein" Coal in Ocean Mine No 3.	
XX. Views of Monongahela and Dunkard Formations.....	258
Fig. 1.—Outcrop of Pittsburg Seam, near Lonaconing, Alle- gany County.	
Fig. 2.—Dunkard Slope, near Frostburg, Allegany County.	
XXI. Views of Maryland Mining Towns.....	322
Fig. 1.—Frostburg.	
Fig. 2.—Lonaconing.	
XXII. Views of Mining Plants.....	326
Fig. 1.—Consolidation Coal Company, Ocean No. 1.	
Fig. 2.—Consolidation Coal Company, Pumping Shaft.	
XXIII. Views of Coal Mining Plants.....	330
Fig. 1.—Consolidation Coal Company, Ocean No. 3.	
Fig. 2.—Consolidation Coal Company, Ocean No. 7.	
XXIV. Map showing the Distribution of the Lower Kittanning Coal...	334
XXV. Views of Coal Mining Plants.....	338
Fig. 1.—Black, Sheridan and Wilson, Union No. 1.	
Fig. 2.—Black, Sheridan and Wilson, Carlos.	
XXVI. Map showing the Distribution of the Upper Freeport Coal.....	342
XXVII. Views of Coal Mining Plants.....	346
Fig. 1.—Georges Creek Coal and Iron Company, Gilmor.	
Fig. 2.—Georges Creek Coal and Iron Company, Gilmor.	
XXVIII. Views of Coal Mining Plants.....	354
Fig. 1.—New Central Coal Company, Koontz.	
Fig. 2.—American Coal Company, Jackson No. 5.	
XXIX. Map showing the Distribution of the Bakerstown Coal.....	362
XXX. Views of Coal Mining Plant.....	370
Fig. 1.—Piedmont Mining Company, Moscow.	
Fig. 2.—Maryland Coal Company, Appleton.	
XXXI. Views of Coal Mining Plants.....	378
Fig. 1.—Davis Coal and Coke Company, Henry No. 7.	
Fig. 2.—Davis Coal and Coke Company, Henry.	

PLATE	FACING PAGE
XXXII. Map of Georges Creek Coal Basin, showing the location of Mining Properties and the Areal Extent of the Pittsburg ("Big Vein") and Lower Coals.....	386
XXXIII. Views of Coal Mining Plants.....	394
Fig. 1.—Piedmont and Georges Creek Coal Company, Washington No. 1.	
Fig. 2.—Braddock Mining Company.	
XXXIV. Map showing the Distribution of the Upper Sewickley Coal.....	402
XXXV. Map showing the Distribution of the Waynesburg Coal.....	406

FIGURE	PAGE
1. Diurnal Variation of the Magnetic Declination at Washington, D. C. (1888-1890) .....	70
2. Diurnal Variation of the Magnetic Inclination at Washington, D. C. (1889-1890) .....	71
3. Diurnal Variation of Curve of Declination and Inclination at Washington, D. C. (1889-1890).....	71
4. Diurnal Variation of the Horizontal Intensity at Washington, D. C. (1889-1890) .....	82
5. Diurnal Variation of the Vertical Intensity at Washington, D. C. (1890) .....	83
6. Diurnal Variation of the Total Intensity at Washington, D. C. (1890).	83
7. Triangulation Stations of U. S. Geological Survey.....	111
8. Diagram showing effect of Convergence of True and Magnetic Meridians .....	113
9. Triangulation Connecting Terminal Points of Boundary Line.....	115
10. Profile of Boundary Line.....	118
11. Secondary Triangulation at Mouth of Savage River.....	119
12. Sketch showing Triangulation at Mouth of Savage River.....	123
13. Profile of Line of Levels across the Top of Big Savage Mountain.....	127
14. Typical Cross-section of Eastern Avenue, Baltimore County, showing Macadam Construction with Slag Foundation and Trap-rock Top Course .....	167
15. Results of 15 Rattler Tests of Soft Brick, showing per cent of wear..	193
16. Results of 15 Rattler Tests of Hard Brick, showing per cent of wear.	193
17. Sketch showing plan, Half Section and Half Elevation of Mould for making Cement Rings used to Determine the Tensile Strength of Cements .....	198
18. Sketch showing Half Section and Half Elevation of Machine for making Wearing Tests of Stone and Brick.....	201
19. Section showing Relative Positions of Prominent Beds in Maryland Coal Measures .....	243

FIGURE	PAGE
20. Map showing Anticlines and Synclines of Coal District.....	260
21. Columnar Sections of Pottsville Formation.....	293
22. Columnar Sections of Allegheny Formation.....	297
23. Columnar Sections of Conemaugh Formation.....	301
24. Columnar Sections of Monongehela Formation.....	309
25. Columnar Sections of Dunkard Formation.....	313
26. Map showing Location of Coal Basins in Maryland.....	318
27. Generalized Section showing Vertical Position of Coal Seams.....	319
28. Diagram showing a Section of the Workings of the "Big Vein" for Mine No. 1, Georges Creek Coal and Iron Company.....	532
29. Coal-cutting Machine, called by the Miners "A Punching Machine" ..	540
30. Sketch illustrating the usual Arrangement of Tracks, Props, and Cross-bars in Rooms.....	544
31. Sketch showing Relations of Overcast and Intake Airways.....	547
32. Sketch of Miner's Lamp used in Georges Creek Basin.....	549
33. Sketch showing Form of Tipple commonly employed in Georges Creek Region .....	553
34. Automatic Pin-puller used by Maryland Coal Companies.....	554
35. Sketch of Body of Mine Cars used by Consolidation Coal Company...	555
36. Sketch of Track Arrangement at Ocean No. 1, Consolidation Coal Company .....	562
37. Sketch showing Track Arrangement, Ocean No. 7, Consolidation Coal Company .....	566
38. Sketch showing Main Tipple, Ocean No. 7, Consolidation Coal Com- pany .....	568
39. Sketch showing Rocker for Dumping Coal used by Consolidation Coal Company .....	569
40. Sketch of Track Arrangement, Ocean No. 8, Consolidation Coal Com- pany .....	570
41. Sketch showing Track Arrangement, Union No. 1, Georges Creek Coal and Iron Company.....	574
42. Sketch of Basket employed in Loading Cars by Georges Creek Coal and Iron Company.....	579
43. Sketch showing Track Arrangement, Union Nos. 9 and 10, Georges Creek Coal and Iron Company.....	582
44. Sketch showing Arrangement of Tipple and Prop-lift, Pine Hill, Georges Creek Coal and Iron Company.....	583
45. Sketch showing Track Arrangement at Appleton and Kingsland Mines, Maryland Coal Company.....	587
46. Sketch showing Track Arrangements, New Detmold Mine, Maryland Coal Company .....	588
47. Sketch showing Tracks and Three-chute Tipple, Jackson Mine, Amer- ican Coal Company.....	590

FIGURE	PAGE
48. Sketch showing Tipple and Tracks, Koontz Mine, New Central Coal Company .....	592
49. Sketch showing Tipple and Plane, Morrison Mine, Frostburg Coal Company .....	596
50. Sketch showing Track Arrangements and Tipples, Moscow Mines....	602
51. Sketch showing Plan of Haulage System, Shamrock Mine, Lonaconing Coal Company .....	605
52. Tipple of the Barnum and Lay Mines, Monroe Mining Company....	608
53. Tipples of the Blaine Mining Company and Garrett County Coal Company at Dill.....	612
54. Track Arrangement of the Blaine Mining Company.....	613
55. View of Calorimeter used in testing coals.....	623

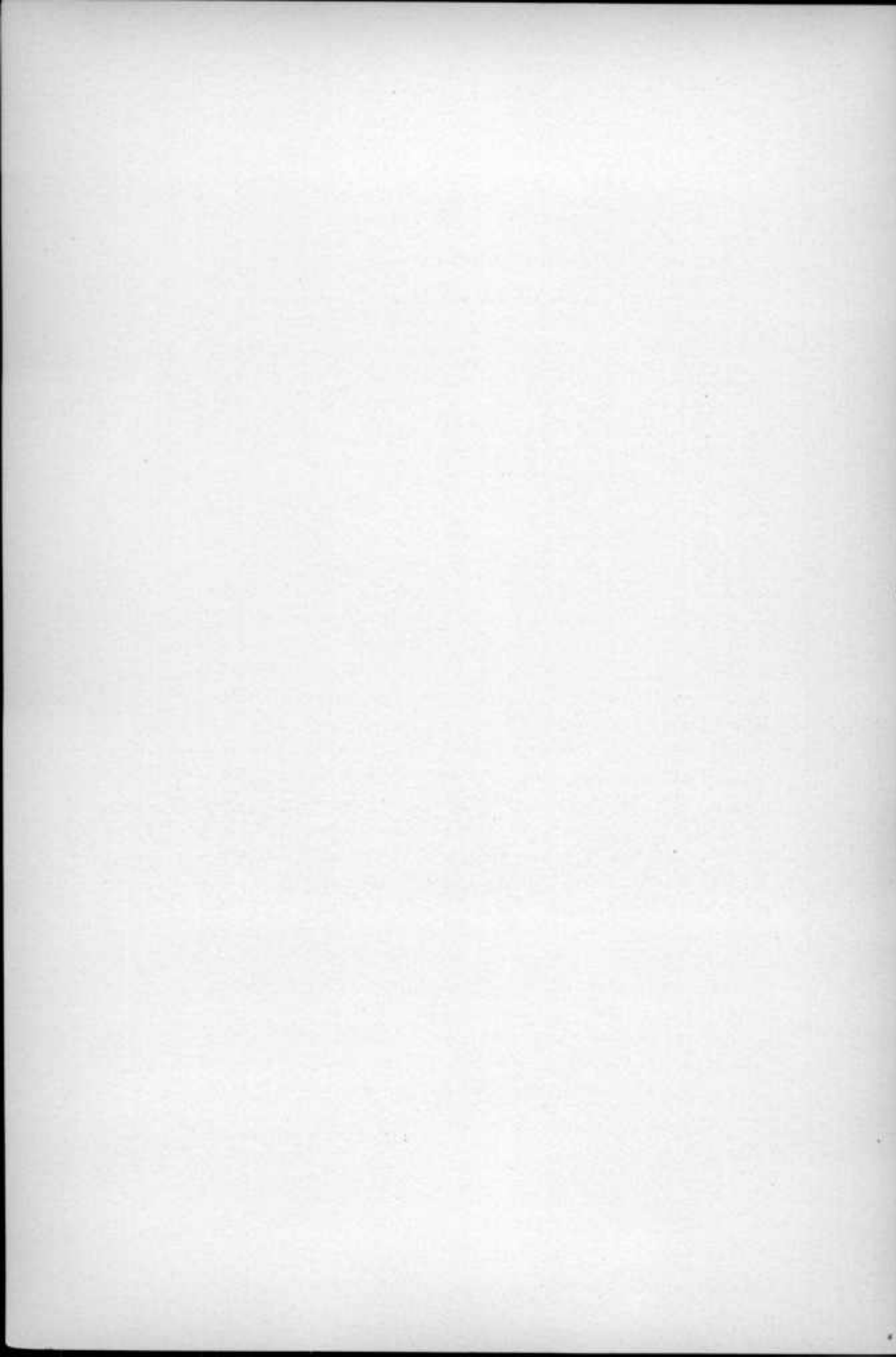

## PREFACE

The present volume, which forms the fifth in the series of general reports, is largely devoted to economic subjects. Each of the parts constituting the volume, has been issued separately at different times, the exact date of which will be indicated in subsequent paragraphs.

The *Second Report on Magnetic Work in Maryland*, by L. A. Bauer forms Part 1 of the volume and completes the account of the detailed magnetic survey which was conducted under the direction of Dr. Bauer during the years 1896 to 1901. Dr. Bauer began this work in 1896 when connected with the University of Chicago, the State Survey meeting nearly all of the cost of his work down to 1899 when he assumed charge of the magnetic operations of the U. S. Coast and Geodetic Survey with which organization the work was further extended under a plan of co-operation which relieved the State of a large part of the expense. The magnetic survey of Maryland is the most complete of any magnetic survey in the world except that of Holland and has resulted in the establishment on the average of one station to every one hundred square miles of territory. Through this survey the magnetic declination, the magnetic inclination, and the magnetic force have been determined in every portion of the State. Maps have been prepared showing each of these several factors. Tables showing the magnetic declination at various periods since early colonial days have been furnished the authorities of every county and have proved of great value in the determination of old property lines and have already been the means of bringing to harmonious settlement many disputed claims. This paper was published in separate form in November, 1902.

The *Final Report on the Survey of the Boundary Line between Allegany and Garrett Counties*, in accordance with an Act passed by the General Assembly in 1898, Chapter 304, by L. A. Bauer

constitutes Part 2 of the volume. The Survey was conducted during the season of 1898, and a preliminary report issued the same year. Dr. Bauer, who was chief of the surveying party, established with great precision a straight line "beginning at the summit of Big Back Bone or Savage Mountain, where that mountain is crossed by Mason's and Dixon's line, and running thence . . . . to the middle of Savage River where it empties into the Potomac River; thence in a straight line to the nearest point or boundary on the State of West Virginia," as required by the Act of 1872 setting off the county of Garrett from that of Allegany. Dr. Bauer clearly shows in his report that the methods employed in the running of the earlier lines were such that straight lines could not be laid off, the result being that the attempts to mark the boundary resulted in lines that do not conform to the provisions of the Act. Since the completion of this report and its publication in special form, the Court has decided that the Chisholm line, run in 1872 and long considered to mark the western limits of Allegany County, shall be in future the boundary line. This report was published in separate form in April, 1903.

The *Third Report on the Highways of Maryland*, with especial reference to the operations of the Highway Division during 1902 and 1903, by A. N. Johnson, comprises Part 3 of the volume. This report contains a discussion of road administration with an outline of a suggested county road law. A table is given showing the mileage of different kinds of roads in Maryland and the estimated cost of the road machinery owned by the several counties of the State. There is also a table showing the road expenditures in each county from 1899 to 1903. The greater portion of the report is devoted to a description of the operations of the Highway Division during 1902 and 1903. Work was carried on in ten counties of the State on 36 different highways, for many of which complete surveys, plans, and specifications were prepared. A large amount of testing was also conducted in the laboratory. This report was published in separate form in December, 1903.

The *Report on the Coals of Maryland*, by Wm. Bullock Clark, with the collaboration of George C. Martin, J. J. Rutledge, B. S. Randolph, N. Allen Stockton, W. B. D. Penniman, and Arthur L. Browne, comprises Part 4 of the volume. This report is the result of many years' investigation of the coal deposits of western Maryland. Elaborate surveys of the coal measures which afforded in part the basis for the reports on Allegany and Garrett counties were made. Many details not incorporated in the county reports are brought out in the present volume including great numbers of sections of the various coal seams together with chemical analyses and calorimetric tests. A series of maps showing the distribution of the several seams is also included, although the large scale maps accompanying the county reports must be employed by those who desire to locate carefully the outcrops of the several seams. The chapters on the History of the Maryland Coal Region by B. S. Randolph and the description of the Coal Mines of Maryland by N. Allen Stockton, well-known mining engineers of the Georges Creek region add much to the value of the report. The tables of chemical analyses and calorimetric tests by the analytical chemists Penniman and Browne, will be greatly appreciated by those seeking information regarding the character of Maryland coal. The other authors have been members of the staff of the State Geological Survey and have been engaged for many years in the study of the geological formations of the western counties of the State. This report was brought out in separate form in December, 1905.

The illustrations employed in this volume have been secured from various sources. Most of them have been made by the members of the State Geological Survey, others have been secured from private sources.

The Survey is especially indebted to the Director of the U. S. Geological Survey, Hon. Charles D. Walcott, who through his Chiefs of Division has co-operated at nearly all points with the State Survey Staff. Much of the information contained in the general chapters of the coal report has been adapted from the more extensive publications issued by the National Survey.



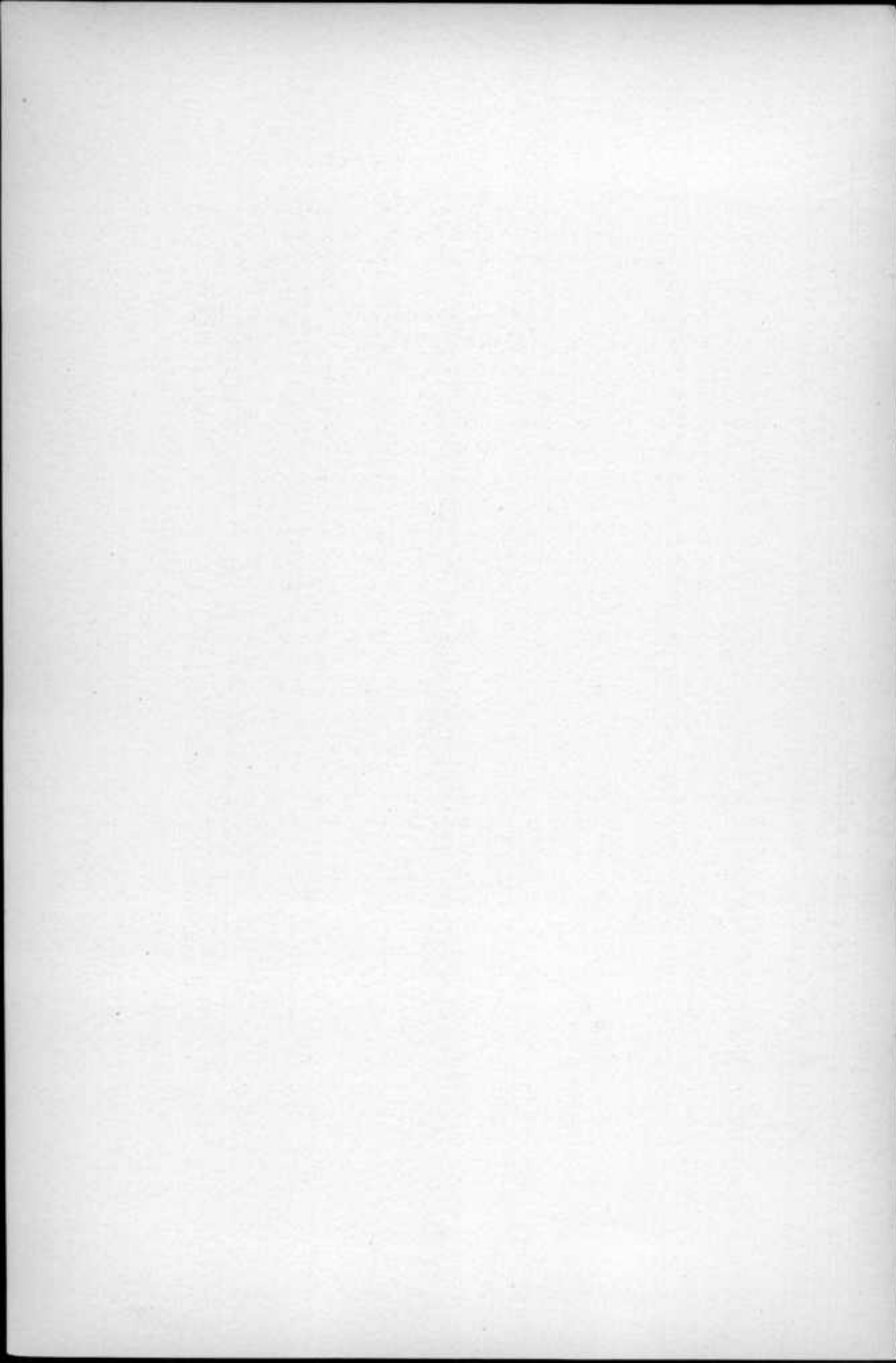

PART I

SECOND REPORT ON MAGNETIC WORK  
IN MARYLAND

BY

L. A. BAUER

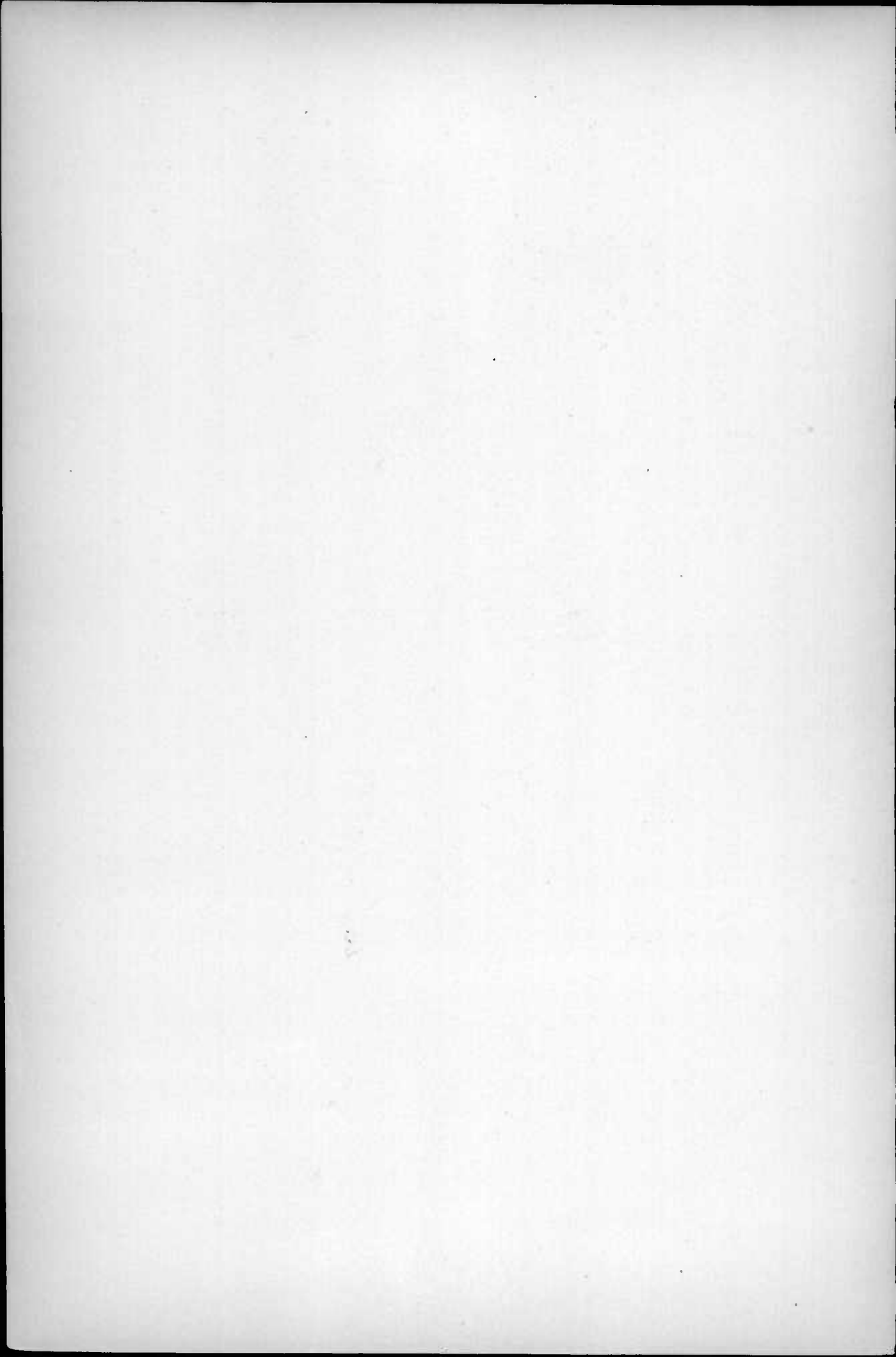



EIGHT-INCH THEODOLITE.

# SECOND REPORT ON MAGNETIC WORK IN MARYLAND

BY

L. A. BAUER.

---

## INTRODUCTION.

The present report gives an account of the magnetic work done in Maryland during the years 1897-1901, and summarizes all of the results obtained thus far.

Most of the observations were made personally by the writer before he took charge of the magnetic work of the United States Coast and Geodetic Survey in May, 1899, and hence were obtained without the facilities which are now at his command. The work would have been greatly facilitated, for example, if, during its progress, the magnetic observatory of the United States Coast and Geodetic Survey, now at Cheltenham, Maryland, 16 miles southeast of Washington, had been in operation.

The magnetic instruments used by him throughout the work were those described and illustrated in the First Report upon the Magnetic Work in Maryland.

The later observations have been made by various members of the Coast and Geodetic Survey under the writer's direction, the results being included in this Report with the courteous permission of the Superintendent of the Survey, Mr. O. H. Tittmann.

The expenses for the 1896, 1897 and 1898 work were borne entirely by the Maryland Geological Survey, with the exception of the stations along the western boundary of the State, the expenses of which were defrayed by the Western Boundary Survey. In 1899, when the writer, as stated, assumed charge of the magnetic operations of the United States Coast and Geodetic Survey, the cost of the

work was shared by the Maryland Geological Survey and the Coast and Geodetic Survey, the latter Survey meeting the observer's salary, and the former paying the incidental expenses. The subsequent work has been done entirely at the expense of the Coast and Geodetic Survey. Thus in 1900, Mr. Baylor, in response to the request of the State Geologist, was instructed by the Superintendent of the Coast and Geodetic Survey, to make magnetic observations and establish meridian lines at the eleven remaining county seats where no such lines had as yet been permanently marked.

The general field work has now been brought to a close. Hereafter the operations will consist, on the part of the Coast and Geodetic Survey, in the re-occupying of certain well-chosen stations, known as "repeat stations," for the purpose of ascertaining the amount of annual change of the magnetic elements. These stations will be distributed over the State in such a manner, that the following two important questions may be solved:

a. Is the annual change (secular change) of the magnetic elements, within a limited region, the same or different over disturbed and undisturbed areas?

b. What are the limits of the region over which the annual change is of the same amount throughout the area?

With the aid of the results from the repeat observations the magnetic maps of Maryland can always be brought up-to-date.

The future work on the part of the State will consist in the delineation of the disturbed areas and the correlation of the magnetic disturbances with geological formations. What a material help the two sciences of geology and terrestrial magnetism may be to each other will appear later.

The State of Maryland now possesses the most detailed magnetic survey of any country, with the exception of Holland. For the sake of comparison the following statement is given:

The magnetic survey of Holland embraces, on the average, one station to every 40 square miles, that of Maryland, one to every 100 square miles, that of England, one to every 139 square miles and that of Missouri, one to every 438 square miles. In this list New

Jersey is not given, since only declinations were observed. The general magnetic survey of the United States contemplates one station to an area about 25-30 miles square.

The "First Report upon Magnetic Work," forming Part V, Vol. I, of the Maryland Geological Survey Reports, will be referred to in the following pages, briefly, as the "First Report." After giving a brief account of the "History and Objects of Magnetic Surveys," it describes the magnetic work of 1896 and gives a tabulation of the results, dealing almost exclusively, however, with the declination observations alone. This, as set forth in that Report, was done for the purpose of putting the results of interest to the land-surveyor in a convenient and compact form. The many letters received from surveyors and others showed their hearty appreciation of the form of presentation of magnetic facts adopted in that Report. It has also been a source of encouragement to all concerned in the work, to note the favorable comments this Report received from reviewers at home and abroad.

The Second Report can hardly hope to compete in popular interest with the first one. It must necessarily deal with more abstruse facts, and abound with numerous tabular statements of the results of the magnetic work up to the present date.

In view of the contemplated early completion of the magnetic surveys of the states surrounding Maryland, by the Coast and Geodetic Survey, it has not been deemed advisable to undertake, in the present Report, to do more than to set forth in sufficient detail the results obtained and to put them in a form convenient for future use. Owing to the irregularity of the area of Maryland, a mathematical analysis of the results would present needless difficulties which will be removed within a very short time by the extension of the work as above stated. With this mathematical analysis will follow most advantageously the discussion of the relationship between local or regional magnetic disturbances and geological features.

It gives me great pleasure to acknowledge gratefully, on behalf of the State Geological Survey, the assistance rendered and the encour-

agement given by the local authorities throughout the State. The newspapers especially deserve mention for the interest shown at all times in the work.

The invaluable assistance given by the Coast and Geodetic Survey in the loan, to the State of Maryland, for four consecutive years of one of its best magnetic outfits, and for coöperating with the State in 1899 and 1900, not only in the field work, but in the labor of reduction of the field results is appreciatively acknowledged. Mention should likewise be made of the aid rendered by the Director of the Canadian Meteorological Service, Professor R. F. Stupart, who has charge of the Toronto Magnetic Observatory, by supplying us promptly with information regarding magnetic storms.

#### THE DISTRIBUTION OF THE MAGNETIC DECLINATION IN MARYLAND FOR JANUARY 1, 1900.

##### EXPLANATORY REMARKS ON THE METHODS OF OBSERVING AND REDUCING.

The present chapter gives a summary of all the results for magnetic declination reduced to January 1, 1900. For an account of the methods of observation and computation and a description, with views, of instruments used, the reader is referred to the First Report.

Tables I-VIII inclusive contain the magnetic declination observations in detail. The headings of the various columns are self-explanatory and require no further remark. Table IX summarizes and condenses all of the declination results obtained between 1896 and 1901, and arranges them alphabetically according to the names of the counties in which the stations are located. Table X gives the latest additional results in the vicinity of Maryland.

As stated in the Introduction, the magnetic observatory of the Coast and Geodetic Survey, at Cheltenham, Maryland, had not yet been established during the progress of the magnetic survey of Maryland; and furthermore, the records of the magnetic observatory at the Naval Observatory at Washington were vitiated by their proximity to electric car-lines to such an extent that all work had to be abandoned. There was, therefore, no nearer magnetic observatory than the one near Toronto, Canada. On account of the distance of the



observatory, however, but limited use was made of it in the reduction of the observations.

A rediscussion, with the aid of the additional observations at the base station of the magnetic survey, Linden, again gave, as in the First Report, *for the present average annual change of the magnetic declination + 3'.0, i. e., west declination is increasing, on the average, annually 3'.*

#### THE ACCURACY OF THE OBSERVATIONS.

An idea of the accuracy attained in the work can be obtained by examining the residuals in the last column of Table I. These differences of the individual results for declination from the mean of all represent the combined effect of the observing error and of the reduction error, the latter, consisting as set forth on page 445 of the First Report of the several parts: *a*, the diurnal variation; *b*, the disturbance variation; *c*, the secular variation, and *d*, the annual variation. It will be seen that a few residuals amount to a little over 2' but that the majority fall below this amount. No. 12, differing 4', has been excluded in taking the mean. From these residuals we find that the *mean square error* of a single result is

$$\mu = \sqrt{\frac{[vv]}{n-1}} = \pm 1'.5 \text{ and}$$

the *probable error* of a single result is

$$\epsilon = \pm .6745 \sqrt{\frac{[vv]}{n-1}} = \pm 1'.01$$

In view of the fact that these figures represent the combined error, as stated, of observation and reduction to mean of day January 1, 1900, the conclusion must be reached that the declinations have been observed and reduced with all needful accuracy.

TABLE I.

Magnetic declinations observed at Base Station, Linden, Montgomery County, between the years 1896 and 1901.

No. of Station.	No. of observation.	DATE OF OBSERVATION.		Local mean time <sup>1</sup> of observation.	Magnetic declination at date of observation (West).	Reduction to Jan. 1, 1900.	Magnetic declination at Jan. 1, 1900 (West).	Difference from mean.
		Month and Day.	Year and Decimal.					
1	1	July 19-30	1896 .56	} Various times } a. m. and p. m. 15:05 9:40, 13:54, 16:29 16:19, 17:12 8:19, 8:58, 9:12, 9:55, 13:38 } Various times during day	3° 25'.8 <sup>2</sup>	+ 10'.33	3° 36'.1	+ 1'.9
	2	August 3, 5	1896 .59		3 29.1	+ 10.23	39.3	- 1.3
	3	September 7	1896 .68		3 25.9	+ 10.03	35.9	+ 2.1
	4	September 28	1896 .74		3 29.4	+ 9.83	39.2	- 1.2
	5	October 4	1896 .76		3 28.9	+ 9.73	38.6	- 0.6
	6	Nov. 24, 25	1896 .90		3 26.7	+ 9.33	36.0	+ 2.0
	7	April 14	1897 .28		3 30.0	+ 8.23	38.2	- 0.2
	8	June 21	1897 .47		3 31.5	+ 7.63	39.1	- 1.1
	9	July 23	1897 .56		3 30.6	+ 7.33	37.9	+ 0.1
	10	July 24	1897 .56		3 30.9	+ 7.33	38.2	- 0.2
	11	September 18	1898 .72		3 34.0	+ 3.83	37.8	+ 0.2
	12	September 19	1898 .72		3 38.5	+ 3.83	42.3	
	13	May 10	1899 .36		3 37.9	+ 1.93	39.8	- 1.8
	14	July 6	1899 .51		3 36.3	+ 1.53	37.8	+ 0.2
	15	July 7	1899 .52		3 35.3	+ 1.53	36.8	+ 1.2
	16	July 8	1899 .52		3 37.2	+ 1.53	38.7	- 0.7
	17	July 18	1900 .55		3 40.2	- 1.63	38.6	- 0.6
	18	July 19	1900 .55		3 42.9	- 1.63	41.3	- 3.3
	19	July 20	1900 .55		3 41.1	- 1.63	39.5	- 1.5
	20	May 17, 18	1901 .37		3 42.2	- 4.13	38.1	- 0.1
	21	May 31,	1901 .42		3 40.4	- 4.33	36.1	+ 1.9
	22	June 1	1901 .42		3 39.9	- 4.33	35.6	+ 2.4
Mean of all except No. 12..					3		38.03	

<sup>1</sup> The hours are counted from midnight, 0 to 24 hours.

<sup>2</sup> Mean of four practice sets made before the magnetic survey was begun.

The true meridian or true bearing of mark was determined at various times throughout the series. All observations were made by L. A. Bauer except Nos. 14, 15 and 16 which were made by J. A. Fleming of the Coast and Geodetic Survey, both using the same instruments.

TABLE II.

Magnetic declinations observed at various stations in Maryland between the years 1896 and 1899.

[All observations made by L. A. Bauer.]

No. of Station.	Station.	Date of Observation.		Local mean time of observations for				Declination at date of observation (West).	Reduction to Jan. 1, 1900.	Declination at Jan. 1, 1900 (West)	Remarks.
		Month and Day.	Year and Decimal 1890+	True Meridian.		Magnetic Meridian.					
2	Upper Marlboro.	Sept. 9	6.69	h. m.	h. m.	h. m.	h. m.	4 59.0	+9.9	5 08.9	
3	La Plata	" 10	6.69	8:31	9:11, 9:34	10:24	9:49, 10:34, 15:58	4 36.8	+9.9	4 46.7	
	"	June 3	7.42	Various times.		14:27, 15:22, 16:22	16:52	4 39.4	+7.7	47.1	Meridian Line.
	"	" 4-5	7.42			16:07, 9:21		4 38.8	+7.7	46.5	
								Mean, 4 46.8			
5	Mechanicsville	Sept. 11	6.70	7:18		10:09		4 43.4	+9.9	4 53.3	
6	Leouardtown	" 12	6.70	16:47		8:44		4 43.2	+9.9	4 53.1	
7	Easton, Hotel	" 16	6.71	9:20		13:32, 14:51		5 32.3	+9.9	5 42.2	
7A	" F. G.	June 24	7.48	14:56, 15:03		15:27, 15:52		5 34.3	+7.6	5 41.9	
7B	" C. H.	" 23-24	7.48	Various times.		11:48, 12:21, 12:41	13.48	5 48.3	+7.6	5 55.9 <sup>1</sup>	} Meridian Line.; Art. L. A.
8	Centreville Acad.	Sept. 17	6.71	14:39		15:43, 16:14		5 47.4	+9.9	5 57.3	
		May 27	7.40	8:46		15:56, 16:23, 16:51		5 57.5	+7.8	6 05.3 <sup>2</sup>	
								Mean, 6 01.3			
8A	" C. H.	" 26, 27	7.40	Various times.		11:29, 12:58		5 58.9	+7.8	6 01.7	Meridian Line.
9	Massey	Sept. 18	6.72	10:00		10:52		6 25.0	+9.8	6 34.8	
10	Ridgely	" 19	6.72	9:32		8:14		5 44.3	+9.8	5 54.1	
11	Hurlock	" 19	6.72	15:07		15:58, 16:34		5 24.9	+9.8	5 34.7	
12	Ocean City	" 21	6.72	10:52		15:54, 16:55		5 27.5	+9.8	5 37.3	
13	Berlin	" 23	6.73	11:08		9:55, 10:23		5 25.3	+9.8	5 35.1	
14	Snow Hill	" 23	6.73	16:54		15:42, 16:33		5 03.8	+9.8	5 13.6	
15	Pocomoke City	" 24	6.73	9:23		10:01, 10:23, 11:03		5 11.8	+9.8	5 21.6	
16	Princess Anne	" 24	6.73	15:33		16:41, 17:31		5 04.3	+9.8	5 14.1	
17	Salisbury, C. H.	" 25	6.73	9:11		10:45, 11:30		5 15.7	+9.8	5 25.5	Artificial L. A.
17A	" M. L.	Dec. 5	6.93	Various times.		8:52, 12:24		5 09.7	+9.2	5 18.9	Meridian Line.
18	Parsonsburg	Sept. 25	6.73	14:58		14:22		5 22.9	+9.8	5 32.7	
19	Cokeysville	" 26	6.74	15:30		14:21		6 02.1	+9.8	6 11.9	
20	Frederick, Asy.	Oct. 5	6.76	16:27, 16:40		15:49, 17:18		4 42.2	+9.7	4 51.9	
20A	" C. H.	" 7	6.77	Various times.		15:32, 16:07		4 41.0	+9.7	4 50.7	Meridian Line.
21	Westminster	" 8	6.77	10:53, 14:02		15:23, 16:01		5 06.9	+9.7	5 16.6	
22	Hagerstown	" 9	6.77	14:16		15:01, 15:47		4 34.2	+9.7	4 43.9	
23	Cumberland	" 10	6.77	15:05		15:55, 16:29		4 02.7	+9.7	4 12.4	
23A	" M. L.	Aug. 14	7.62	Various times.		16:44		4 06.4	+7.1	4 13.5	Meridian Line.
24	Oakland, S. H.	Oct. 12	6.78	10:51		8:57, 9:57, 12:51, 13:24		3 14.5	+9.7	3 24.2	Severe mag. storm
24A	" C. H.	July 29	7.57	Various times.		17:26		3 23.0	+7.3	3 30.3	} Meridian Line, South Stone.
		Aug. 2	7.58			10:02, 10:50, 13:49, 14:50, 16:30, 15:39		3 25.7	+1.7	27.4	
		June 5	9.43			8:05, 8:37, 19:15, 10:00, 13:09, 13:51		Mean, 3 28.8			
27	Elkton	Oct. 15	6.79	8:23, 8:33		9:42, 10:24, 12:25		5 12.0	+9.6	5 21.6	
28	Prince Frederlek.	" 19	6.80	15:36, 8:42		16:27, 16:59		5 10.4	+9.6	5 20.0	
29	Belair, Hotel	" 20	6.80	9:56		10:56, 11:31		5 38.4	+9.6	5 48.0	
	" " "	May 7	7.35	16:20, 16:21		8:35, 9:46, 10:06, 10:55		5 44.6	+8.0	5 52.6	} Region of marked disturb- ance; gabbro rocks.
								Mean, 5 50.3			
29A	" Dallam	" 6	7.34	15:29		5:36		4 35.8	+8.0	4 43.8	
	" " "	" 15	7.37	14:29, 14:35		14:40		4 38.5	+7.9	4 46.4	
								4 45.1			

<sup>1</sup> Mr. R. H. Blain found on February 12-14, 1900, the declination at the West Monument to be 6° 07', some additional changes in the Court House having been made since my observations in 1897.

<sup>2</sup> The Station of 1897 was close to that of 1896, and there seemingly was no cause for artificial local disturbance. The large difference of 8' from the 1896 result, unless it is to be referred to a magnetic storm, cannot be accounted for.

TABLE II.—Concluded.

Magnetic declinations observed at various stations in Maryland between the years 1896 and 1899.

[All observations made by L. A. Bauer.]

No. of Station.	Station.	Date of Observation.		Local mean time of observations for				Declination at date of observation (West).	Reduction to Jan. 1, 1900.	Declination to Jan. 1, 1900 (West)	Remarks.
		Month and Day.	Year and Decimal. 1890+	Truo meridian.		Magnetic Meridian.					
29B	Belair N. E. M....	May 6, 7	7.34	h. m. h. m. h. m.	h. m. h. m. h. m.	5 01.0	+8.0	5 09.0	Meridian Line; Art. L. A.		
30	Annapolis .....	Oct. 21	6.80	10:31, 10:42...	14:38, 15:11 .....	5 16.1	+9.6	5 25.7			
31	Ellicott City.....	" 22	6.81	15:07 .....	15:51, 16:22 .....	4 44.3	+9.6	4 53.9			
33	Belcamp .....	Nov. 6	6.85	10:20 .....	13:31, 13:40 .....	6 05.7	+9.4	6 15.1			
37	Cardiff, R. R. ....	" 7	6.85	10:39, 10:41 .....	11:27 .....	4 25.9	+9.4	4 35.3	Region of marked disturbance due to serpentine rocks.		
37B	" Bd. St. ....	May 14	7.37	9:21 .....	9:54 .....	5 35.5	+7.9	5 43.4			
37J	" Sch. H. ....	" 14	7.37	7:48, 7:54, 7:58	8:36 .....	7 27.7	+7.9	7 35.6			
37K	" P. S. Q. ....	" 14	7.37	11:05, 11:06 .....	11:26 .....	6 51.1	+7.9	6 59.0			
38	Forest Hill ...	Nov. 7	6.85	15:43 .....	15:08 .....	5 24.5	+9.4	5 33.9			
40	Unity .....	" 14	6.87	9:17 .....	10:09, 10:37 .....	5 36.0	+9.4	5 45.4			
41	Damascus .....	" 14	6.87	16:09 .....	15:31, 15:55 .....	4 02.8	+9.4	4 12.2			
42	Forest Glen .....	" 25	6.90	12:51 .....	10:30, 10:56 .....	3 37.0	+9.3	3 46.3			
1A	Linden, A. S. ....	" 25	6.90	14:41 .....	15:38 .....	3 39.0	+9.3	3 48.3			
43	Crisfield .....	Dec. 7	6.93	9:25, 15:53 ...	8:55, 10:04, 11:10	4 44.4	+9.2	4 53.6			
44	Cambridge .....	April 17	7.29	Various times.	16:03, 17:11 .....	5 24.0	+8.1	5 32.1	Meridian Line.		
45	Tilghman I. ....	" 19	7.30	9:53, 17:00 ...	10:55, 11:20, 12:57.	5 23.4	+8.1	5 31.5			
47	Towson, N. M. ..	" 24	7.31	Various times.	10:11, 13:41 .....	5 50.0	+8.1	5 58.1	Meridian Line.		
	" " ..	" 27	7.32	.....	15:56, 16:16 .....	5 52.7	+8.0	6 00.7			
						Mean,		5 59.4			
47A	" S. M. ....	" 26	7.32	.....	17:30, 17:44 .....	5 41.6	+8.0	5 49.6			
		" 27	7.32	.....	8:18 .....	5 42.2	+8.0	5 50.2			
						Mean,		5 49.9			
48	Hyde's .....	May 7	7.35	17:06 .....	17:22 .....	5 44.7	+8.0	5 52.7			
49	Churchville.....	" 8	7.35	10:53 .....	11:23 .....	5 43.2	+8.0	5 51.2			
50	Thomas Run .....	" 8	7.35	14:02 .....	14:32 .....	5 37.8	+8.0	5 45.8			
52	Highland .....	" 14	7.37	14:13 .....	14:34 .....	5 33.2	+7.9	5 41.1			
53	Minefield .....	" 14	7.37	16:51 .....	17:01 .....	6 53.7	+7.9	7 01.6			
54	Dublin .....	" 15	7.37	7:39 .....	6:52 .....	10 00.9	+7.9	10 08.5	On gabbro rock.		
56	Bradshaw .....	" 15	7.37	16:05 .....	16:26 .....	5 18.8	+7.9	5 26.7			
57	Chestertown, C. H.	" 28	7.41	1:37 .....	11:43, 13:34, 16:46.	5 50.0	+7.8	5 57.8	Meridian Line; Art. L. A.		
	" " ..	" 29	7.41	Various times.	9:16, 13:41, 14:20.	5 50.0	+7.8	5 57.8			
57A	" Coll. ....	" 31	7.41	15:39, 15:48 ...	16:13, 16:27, 16:40, 17:25.	5 47.0	+7.8	5 54.8			
58	Telchester .....	June 1	7.41	16:03 .....	17:04 .....	5 37.1	+7.8	5 44.9			
59	Oxford .....	" 25	7.48	15:52, 15:59 ..	14:51, 15:31 .....	5 33.9	+7.6	5 41.5			
60	Fair Haven .....	" 26	7.49	14:46 .....	12:18, 14:30 .....	5 23.2	+7.5	5 30.7			
62	Rockville .....	July 7-8	7.51	7:19, 7:22 ...	18:02, 7:46 .....	5 24.6	+7.5	5 32.1			
63	Webb .....	" 16	7.54	17:19 .....	17:04, 17:54 .....	5 02.3	+7.4	5 09.7			
64	Kent L. S. B. ....	" 19	7.55	9:11, 9:17, 15:11	10:05, 11:45, 14:46.	5 21.4	+7.4	5 28.8			
67	Seneca .....	" 26	7.57	15:00 .....	15:22 .....	2 30.9	+7.3	2 38.2			
68	Maryl. Heights, S.	" 27	7.57	16:37 .....	15:59, 16:58 .....	4 24.0	+7.3	4 31.3			
68A	" " F. ....	" 28	7.57	9:05, 9:09, 9:12	10:08, 10:46 .....	4 14.4	+7.3	4 21.7			
69	Hancock .....	" 28	7.57	15:12, 15:18 ..	15:56, 16:36 .....	4 24.9	+7.3	4 32.2			
70	Corunna .....	" 31	7.58	10:25, 10:33, 13:08, 13:15 ...	11:35, 12:05, 14:40.	3 16.2	+7.3	3 23.5			
71	Westernport .....	Aug. 3	7.59	15:16 .....	14:44 .....	3 46.2	+7.2	3 53.4			
82	Lonaconing .....	" 31	8.60	Various times.	15:51 .....	3 51.0	+4.0	3 55.0			

<sup>3</sup> In order to obtain the effect from the large gabbro rocks in this locality, the observation was purposely made over one of the largest of these rocks jutting out of the ground.

<sup>4</sup> This low value has been verified by H. W. Vehrenkamp, Aid, C. & G. S., who obtained, at a slightly different station, on July 23, 1899, 2° 31'.4; his value reduced to 1900. 0 is 2° 32'.8.

TABLE III.

*Magnetic declinations observed by Western Boundary Survey of Maryland in 1897.*

[These observations were made along the western boundary line of Maryland, by L. A. Bauer, astronomer and magnetician to the Western Boundary Survey. The same instruments and methods were used as in the magnetic survey.]

No. of Station.	Station.	Date of Observation.		Local mean time of observations for						Declination at date of observation (West).	Reduction to Jan. 1, 1900.	Declination at Jan. 1, 1900 (West)	Remarks.		
		Month and Day.	Year and Decimal 1890+	True Meridian.			Magnetic Meridian.								
72	Fairfax Stone...	Aug. 4, 6	7.59	Various times, p.m.			15:49, 16:15, 16:27			3 09.2	+7.2	3 16.4	} 463 ft. N. of 72		
72A	" " ....	" 5, 6	7.59	From angles.....			Various times a & p			3 05.2	+7.2	3 12.4			
73	Camp Fairfax....	" 7	7.60	10:12, 10:20, 13:20, 13:27.....			7:42, 13:56.....			3 06.5	+7.2	3 13.7			
		" 8	7.60	.....			7:55, 10:00, 14:02..			3 05.1	+7.2	3 12.3			
							Mean,					3 13.0			
74	Backbone Mtn...	" 22	7.64	} Horizontal angles			11:21, 13:54, 16:30, 17:50.....			3 09.2	+7.1	3 16.3			
		" 23	7.64				8:34, 10:30, 13:15, 15:44.....			6.0			+7.1	3 13.1	
		" 28	7.65				8:42, 13:47, 17:16...			5.5			+7.0	3 12.5	
										Mean,					3 14.0
76	Foley Mountain..	Sept. 16	7.71	} " "			8:03, 9:53, 13:54...			3 16.0	+6.9	3 22.9			
		" 21	7.72				12:19, 13:12, 16:19			16.0			+6.8	3 22.8	
										Mean,					3 22.8
77	Lower Hill.....	" 25	7.74	} " "			16:49.....			3 16.7	+6.8	3 23.5			
78	Snaggy Mountain.	" 28	7.74				13:16.....			} 3 37.2			+6.8	3 44.0	
		" 29	7.74				10:44, 12:58.....								
79	Taylor's Hill....	" 30	7.75	} " "			14:37.....			3 31.7	+6.8	3 38.5			
		Oct. 1	7.75				8:56, 10:06.....								
80	Fike's Hill, E....	" 8	7.77	} " "			14:49, 15:11.....			3 40.3	+6.7	3 47.0			
81	" " W.....	" 13	7.78				13:36.....						3 40.4	+6.7	3 47.1
82	Mason & Dixon L.	" 16	7.79	} " "			10:33.....			3 47.5	+6.6	3 54.1			

TABLE IV.

*Magnetic declinations observed under the joint auspices of the Maryland Geological Survey and the United States Coast and Geodetic Survey in 1899.*

[These observations were made by L. A. Bauer with same magnetometer as used in previous work. The main purpose was to map the regions of marked disturbance.]

No. of Station.	Station.	Date of Observation.		Local mean time of observations for						Declination at date of observation (West).	Reduction to Jan. 1, 1900.	Declination at Jan. 1, 1900 (West)	Remarks.	
		Month and Day.	Year and Decimal 1800+	True meridian.			Magnetic Meridian.							
				h. m.	h. m.	h. m.	h. m.	h. m.	h. m.	° /	'	° /	'	
84	Gaithersburg . . . . .	May	159.37	14:38,	14:49	15:43,	16:13	5 17.1	+1.9	5 19.0 <sup>1</sup>				
85	Lisbon . . . . .	"	169.37	9:36,	9:43	10:49		4 41.8	+1.9	4 43.7				
86	Sykesville . . . . .	"	169.37	15:15,	15:21, 15:29	16:11,	16:34	6 24.0	+1.9	6 25.9				
87	Reisterstown . . . . .	"	179.38	9:57,	10:14	10:59,	11:24	7 02.6	+1.9	7 04.5				
88	Manchester . . . . .	"	199.38	6:59,	7:12	7:45		5 34.7	+1.9	5 36.6				
89	Taneytown . . . . .	"	199.38	14:20,	14:28	15:48		4 57.8	+1.9	4 59.7				
90	Liberty . . . . .	"	209.38	9:47,	10:03	7:42,	8:30, 0:38,							
						13:01		4 47.2	+1.9	4 49.1				
91	McHenry . . . . .	June	69.43	10:11,	10:22	11:10,	12:47	3 36.3	+1.7	3 38.0				
92	Accident . . . . .	"	69.43	16:41,	16:49	17:22,	17:57	3 44.8	+1.7	3 46.5				
93	Grantsville . . . . .	"	79.43	14:54,	15:03	13:19,	14:00	3 58.4	+1.7	4 00.1				
94	New Germany . . . . .	"	89.44	10:07,	14:31, 14:35	7:34,	8:20, 9:17,							
						13:07,	13:38, 14:13	3 59.0	+1.7	4 00.7				
95	Swanton . . . . .	"	99.44	7:29,	7:37	9:13,	11:43	3 36.6	+1.7	3 38.3				
96	Paw Paw . . . . .	"	129.45	14:46		8:56,	9:26, 12:52	4 10.8	+1.6	4 12.4 <sup>2</sup>				
97	Parkton . . . . .	"	149.45	9:26,	10:44	11:39,	11:54	5 59.1	+1.6	6 00.7				
98	Havre de Grace . . . . .	"	209.47	10:29,	10:35, 15:38,									
				15:52		7:58,	8:39, 9:48,							
						14:50		5 24.4	+1.6	5 26.0				
99	Betterton . . . . .	"	219.47	9:42,	9:58, 16:54,	11:05,	11:49, 13:43,							
				17:08		14:32		4 03.9	+1.6	4 05.5 <sup>3</sup>				
100	Rising Sun . . . . .	"	229.47	10:56,	11:10, 14:08,	8:59,	9:26, 13:34	5 08.8	+1.6	5 10.4 <sup>3</sup>				
				14:15										
101	Calvert . . . . .	"	229.47	15:37,	15:42	16:02,	16:18	5 26.0	+1.6	5 27.6				

<sup>1</sup> See additional stations at Gaithersburg further on. Mr. E. Smith, of the Coast and Geodetic Survey, obtained May 3, 4, 1898, at same station as No. 84, 5° 13'.2, which reduced to 1900 gives 5° 18'.2. Mean of the two values, 5° 18'.6.

<sup>2</sup> Clouds prevented getting a complete set of azimuth observations. The meridian depends upon a single altitude, telescope direct, and collimation observations; the declination may be out several minutes of arc. *This station is in West Virginia.*

<sup>3</sup> Observation made under L. A. Bauer's supervision by J. A. Fleming, Ald. C. & G. S.

TABLE V.

Magnetic declinations observed by the United States Coast and Geodetic Survey in the vicinity of Gaithersburg in 1899.

[These observations were made under L. A. Bauer's direction, using same kind of instruments as heretofore.]

No. of Station.	Station.	Date of Observation.		Local mean time of magnetic observations.	Declination at date of observation (West).	Reduction to Jan. 1, 1900.	Declination at Jan. 1, 1900 (West)	Observer.	Remarks.
		Month and Day.	Year and Decimal 1890+						
84A	Gaithersburg I.	July 6	9.51	h. m. h. m. h. m.	5 45.3	+1.55	46.8	J. A. Bauer.	Purpose of these observations was to map out regions of marked local disturbance in vicinity of Gaithersburg.
		" 7	9.52	11:40 . . . . .	5 41.7	+1.45	43.1	H. W. Vehrenkamp.	
		" 10	9.52	8:00, 8:26, 9:32, 13:42, 14:06 . . . . .	5 42.0	+1.45	43.4	J. A. Fleming.	
		" 24	9.56	7:47, 8:16, 9:29, 13:33	5 41.5	+1.35	42.8	H. W. Vehrenkamp.	
84B	II.	" 8	9.52	9:00, 13:41 . . . . .	5 57.5	+1.45	55.9	"	
		" 11	9.52	7:57, 8:27, 9:35, 11:23, 13:52 . . . . .	5 51.6	+1.45	53.0	J. A. Fleming.	
84C	III.	" 10	9.52	7:59, 8:17, 8:42, 13:20	5 26.8	+1.45	28.2	H. W. Vehrenkamp.	
102	Waring . . . . .	" 13	9.53	8:29, 9:20, 13:16, 13:41 . . . . .	0 48.8	+1.40	50.2	"	
103	Middlebrook . . .	" 14	9.53	8:35, 9:07, 10:01, 13:24 . . . . .	4 49.7	+1.44	51.1	"	
104	Cross Roads I.	" 15	9.54	7:54, 8:16, 13:21 . . .	6 03.0	+1.46	04.4	"	
105	Cross Roads II. . .	" 17	9.54	7:45, 8:13, 13:26 . . .	6 09.4	+1.46	10.8	"	
106	Redland . . . . .	" 18	9.54	8:01, 8:28, 9:30, 13:21	6 37.4	+1.46	38.8	"	
107	Derwood . . . . .	" 19	9.55	7:43, 8:06, 13:22 . . .	8 22.5	+1.48	23.9	"	
108	Hunting Hill. . . .	" 20	9.55	7:58, 8:28, 9:34, 13:28	6 08.5	+1.46	09.9	"	
109	Quince Orchard. . .	" 21	9.55	8:00, 8:22, 9:27, 13:42	4 15.1	+1.44	16.5	"	
67A	Seneca . . . . .	" 22	9.56	10:13, 13:27 . . . . .	2 31.4	+1.32	32.7	"	
110	Cheltenham I.	{ Sept. 18,	9.72	Various times . . . . .	4 55.6	+0.84	56.4	J. A. Fleming.	
		19, 20. . . . .							
		Sept. 21, 22							
		{ Sep. 23, 25							
110A	Cheltenham I.	III. { Oct. 2	9.74	" " . . . . .	4 57.9	+0.84	58.7	"	
		IV. Sept. 27	9.74	" " . . . . .	5 02.0	+0.85	02.8	"	
		V. " 28	9.74	" " . . . . .	5 02.8	+0.85	03.6	"	
		VI. " 29	9.74	" " . . . . .	4 58.5	+0.84	59.3	"	
	VII. " 30	9.75	" " . . . . .	5 14.0	+0.85	14.8	"		

Examining site for proposed magnetic observatory.

TABLE VI

*Magnetic declinations observed in 1898 along boundary line between Allegany and Garrett Counties, Maryland.*

[These observations were made in connection with the survey of the boundary line in the summer of 1898, L. A. Bauer being chief of party and W. M. Brown the observer. Mr. Brown's readings, taken with the needle to his engineer's transit were reduced to the mean of day and epoch and referred to Coast and Geodetic Survey Magnetometer No. 18. See Report on the Boundary Line. The stations are fully described in the Boundary Report.]

No.	Station.	Latitude.	Longitude West of Greenwich.	Declination	
				Middle of 1898 (West).	At Jan. 1, 1900 (West).
111	Mound 1.....	39° 48'.4	78° 54'.8	4° 07'.7	4° 12'.2
112	" 2.....	39 42.5	78 55.4	4 06.5	4 11.0
113	Sampson Rock.....	39 42.4	78 55.7	3 58.4	4 02.9
114	Mound 4.....	39 41.2	78 56.1	4 04.1	4 08.6
115	" 5.....	39 40.5	78 56.6	4 04.7	4 09.2
116	" 7.....	39 39.3	78 57.3	3 59.9	4 04.4
117	" 8.....	39 38.6	78 57.7	3 59.3	4 03.8
118	" 9.....	39 37.9	78 58.2	4 03.4	4 07.9
119	" 10.....	39 37.3	78 58.5	3 57.9	4 02.4
120	" 13.....	39 35.7	78 59.5	3 53.3	3 57.8
121	" 14.....	39 35.1	78 59.9	3 54.3	3 58.8
122	" 15.....	39 34.7	79 00.1	3 54.6	3 59.1
123	" 18.....	39 33.0	79 01.2	3 56.4	4 00.9
124	" 19.....	39 32.8	79 01.3	3 55.6	4 00.1
125	" 21.....	39 31.8	79 01.9	3 51.3	3 55.8
126	" 22.....	39 31.0	79 02.4	3 51.2	3 55.7
127	" 23.....	39 30.1	79 03.0	3 48.5	3 53.0
128	" 24.....	39 29.7	79 03.3	3 47.5	3 52.0
129	" 26.....	39 28.8	79 04.0	3 40.1	3 44.6
130	" 27.....	39 28.8	79 04.0	3 07.1	3 11.6 <sup>1</sup>
131	Daniels Δ <sup>2</sup> .....	39 28.0	79 02.7	3 11.1	3 15.6 <sup>1</sup>

<sup>1</sup>Local disturbing influence exists at these stations.

<sup>2</sup>This station is in West Virginia, on the hills back of Piedmont.



TABLE VII.

Magnetic declinations observed by the United States Coast and Geodetic Survey in 1900.

No.	Station.	Date of Observation.		Declination at date of observation (West).	Reduction to Jan. 1, 1900.	Declination at Jan. 1, 1900 (West)	Observer.	Remarks.
		Month and Day.	Year and Decimal 1890+					
26A	Dickerson . . . . .	March	31	10.25 2° 33'.0	- 1.8	3° 32'.2	J. D. Thompson	
70	Corunna . . . . .	May	28, 29	10.41 3 22.9	-1.2	3 21.7	W. M. Brown.	N. Merid. Stone.
14A	Snow Hill, . . . S	June	1	10.41 5 23.6	-1.2	5 22.4	J. B. Baylor.	S. "
14B	" " N	"	1	10.41 5 23.8	-1.2	5 22.6	"	N. "
16A	Princess Anne, S	"	4	10.42 5 16.6	-1.3	5 15.3	"	S. "
16B	" " N	"	4	10.42 5 11.8	-1.3	5 10.5	"	N. "
132	Denton . . . . . S	"	7	10.43 5 54.8	-1.3	5 53.5	"	S. "
132A	" " N	"	7	10.43 6 04.3	-1.3	6 03.0	"	N. "
27A	Elkton . . . . . S	"	9	10.44 5 21.3	-1.3	5 20.0	"	S. "
27B	" " N	"	9	10.44 5 51.5	-1.3	5 50.2	"	N. "
31A	Ellicott City. S	"	12, 13	10.45 5 12.9	-1.4	5 11.5	"	S. "
31B	" " N	"	12, 13	10.45 4 59.6	-1.4	4 58.2	"	N. "
21A	Westminster. S	"	15	10.45 4 45.0	-1.4	4 43.6	"	S. "
21B	" " N	"	18	10.46 4 48.1	-1.4	4 46.7	"	N. "
30A	Annapolis . . . S	"	21	10.47 5 30.8	-1.4	5 29.4	"	S. "
30B	" " N	"	21	10.47 5 34.8	-1.4	5 33.4	"	N. "
28A	Prince Frederick . . . . . S	"	25	10.48 5 24.3	-1.4	5 22.9	"	S. "
28B	" " N	"	25	10.48 5 18.6	-1.4	5 17.2	"	N. "
2A	Up. Marlboro. S	"	29	10.49 5 06.6	-1.5	5 05.1	"	S. "
2B	" " N	"	29	10.49 5 05.0	-1.5	5 03.5	"	N. "
6A	Leonardtwn S	"	27	10.49 4 54.6	-1.5	4 53.1	"	S. "
62A	Rockville. . . . . S	July	2	10.50 5 46.2	-1.5	5 44.7	"	S. "
22A	Hagerstown . . . N	June	9	10.44 4 36.7	-1.3	4 35.4	J. A. Fleming.	N. "

TABLE VIII.

Magnetic Declinations by Surveyors.

[These observations were made with care, using ordinary compass needle belonging to Mr. Brown's transit which he had repeatedly compared with Magnetometer No. 18.]

No.	Station.	Latitude.	Longitude West of Greenwich.	Date.		Declination at date of observ'n (West).	Reduction to January 1, 1900.	Declination at Jan. 1, 1900 (West)	Observer.
				Day and Month.	Year and Decimal 1890+				
83	Lonaconing . . . . .	39° 33'.6	78° 59'.1	Sept. 1	8.67	3° 53'.6	+4.0	3° 57'.6	W. M. Brown.
				Dec. 23	8.98	3 52.3	+3.1	3 55.4	
				Mean,				3 56.5	
70	Corunna . . . . .	39 16.6	79 22.6	Sept. 5	8.68	3 19.1	+4.0	3 23.1	"
				Dec. 20	8.97	3 13.5	+3.1	3 16.6	
				Feb. 23	9.15	3 18.1	+2.6	3 20.7	
				Mean,				3 20.1	
24	Oakland . . . . .	39 24.6	79 24.6	June 24	8.48	3 24.4	+4.6	3 29.0	"
				Jan. 13	9.04	3 22.2	+2.9	3 25.1	
				June 13	9.45	3 19.8	+1.6	3 21.4	
				Mean,				3 25.2	

TABLE IX.

Recapitulation of all values of the magnetic declinations observed in Maryland between 1896-1901, reduced to January 1, 1900, and arranged alphabetically according to county.

No.	Station.	County.	Latitude.	Longitude.	Declination Jan. 1, 1900, (West.)	Remarks.
71	Westernport .....	Allegany .....	39 28.979	02.2	3 53.4	North Bank Potomac.
96	Paw Paw .....	" .....	39 32.178	26.2	4 12.4	Field, S. R. R. Sta., [W. Va.]
83	Lonaconing .....	" .....	39 33.678	59.1	3 55.0	Near Md. Coal Co's Office.
23	Cumberland .....	" .....	39 39.278	46.4	4 12.4	Camp Hill.
23A	" .....	" .....	39 40.078	46.0	4 13.5	Mer. L., S. M., Poor H.
131	Daniel's Farm .....	Allegany-Garrett Boundary Line.	39 28.079	03.7	3 15.6	[W. Va.]  Boundary Line Allegany and Garrett Counties. [For further information see Report on Boundary Line.]
130	Mound 27 .....		39 28.879	04.0	3 11.6	
129	" 26 .....		39 28.879	04.0	3 44.6	
128	" 24 .....		39 29.779	03.3	3 52.0	
127	" 23 .....		39 30.179	03.0	3 53.0	
126	" 22 .....		39 31.079	02.4	3 55.7	
125	" 21 .....		39 31.879	01.9	3 55.8	
124	" 19 .....		39 32.879	01.3	4 00.1	
123	" 18 .....		39 33.079	01.2	4 00.9	
122	" 15 .....		39 34.779	00.1	3 59.1	
121	" 14 .....		39 35.178	59.9	3 58.8	
120	" 13 .....		39 35.778	59.5	3 57.8	
119	" 10 .....		39 37.378	58.5	4 02.4	
118	" 9 .....		39 37.978	58.2	4 07.9	
117	" 8 .....	39 38.678	57.7	4 03.8		
116	" 7 .....	39 39.378	57.3	4 04.4		
115	" 5 .....	39 40.578	56.6	4 09.2		
114	" 4 .....	39 41.278	56.1	4 08.6		
113	Sampson Rock .....	39 42.478	55.7	4 02.9		
112	Mound 2 .....	39 42.578	55.4	4 11.0		
111	" 1 .....	39 43.478	54.8	4 12.2		
60	Fair Haven .....	Anne Arundel .....	38 45.476	33.4	5 30.7	Hill near Steamboat Landing.
30	Annapolis .....	" .....	38 58.976	29.1	5 25.7	Nav. Acad., near Obs'y.
30A	" .....	" .....	38 59.176	29.5	5 29.4	Merid. L., S. M. } Nav.
30B	" .....	" .....	38 59.176	29.5	5 33.4	" " N. M. } Acad.
63	Webb .....	" .....	39 05.376	40.5	5 09.7	Near Triang. Sta.
32	Baltimore .....	Baltimore .....	39 15.976	34.9	5 32.1	Fort McHenry.
47	Towson .....	" .....	39 24.076	36.4	5 59.4	Merid. L., N. Mon.
47A	" .....	" .....	39 24.076	36.4	5 49.9	" " S. "
56	Bradshaw .....	" .....	39 25.376	22.6	5 26.7	Col. Taylor's grounds.
87	Reisterstown .....	" .....	39 27.876	50.0	7 04.5	Near Franklin School.
48	Hyde's .....	" .....	39 29.176	29.2	5 52.7	Garden back R. R. office.
19	Cockeysville .....	" .....	39 29.176	38.6	6 11.9	Cockey's Lot.
97	Parkton .....	" .....	39 39.076	40.0	6 00 7	Hill, w. R. R.
28	Prince Frederick .....	Calvert .....	38 32.476	34.9	5 20.0	1896 Sta., C. H.
28A	" .....	" .....	38 32.476	34.9	5 22.9	Merid. L., S. M. } C. H.
28B	" .....	" .....	38 32.476	34.9	5 17.2	" " N. M. } Square.
132	Denton, S. M. .....	Caroline .....	38 53.375	52.0	5 53.5	Merid. L., S. Mon.
132A	" N. M. .....	" .....	38 53.375	52.0	6 03.0	" " N. "
10	Ridgely .....	" .....	38 57.475	52.6	5 54.1	School House.
86	Sykesville .....	Carroll .....	39 22.376	57.7	6 25.9	Field near Brick School.
89	Taneytown .....	" .....	39 39.577	10.7	4 59.7	Meier's Academy.
88	Manchester .....	" .....	39 39.676	52.8	5 36.6	Lot back School House.
21	Westminster .....	" .....	39 34.676	59.7	5 16.6	C. H. Lot; Loc. Dis.
21A	" .....	" .....	39 34.676	59.7	4 43.6	Merid. L., S. M. } West. Md.
21B	" .....	" .....	39 34.676	59.7	4 46.7	" " N. M. } Col.
27	Elkton .....	Cecil .....	39 36.575	49.5	5 21.6	High School, near S. M.
27A	" .....	" .....	39 36.575	49.5	5 20.0	Merid. L., S. M.
27B	" .....	" .....	39 36.575	49.5	5 50.2	" " N. M., Loc. Dis.

TABLE IX.—Continued.

Recapitulation of all values of the magnetic declinations observed in Maryland between 1896-1901, reduced to January 1, 1900, and arranged alphabetically according to county.

No.	Station.	County.	Latitude.	Longitude.	Declination Jan. 1, 1900. (West.)	Remarks.
100	Rising Sun.....	Cecil .....	39 41.576 03.3	76 03.3	5 10.4	H. J. Briscoe's Field.
101	Calvert .....	" .....	39 41.875 57.7	57.7	5 27.6	School Lot.
3	La Plata.....	Charles .....	38 31.876 58.7	58.7	4 46.8	Meridian Line.
44	Cambridge.....	Dorchester .....	38 34.376 04.6	04.6	5 32.1	Merid. L., S. E. Mon.
11	Hurlock .....	" .....	38 38.075 52.7	52.7	5 34.7	School " "
20	Frederick.....	Frederick .....	39 24.777 24.8	24.8	4 51.9	Deaf and Dumb Asylum.
20A	" .....	" .....	39 25.077 24.6	24.6	4 50.7	Merid. L., C. H. Lot } Possible Local Dist. }
90	Libertytown .....	" .....	39 29.077 13.9	13.9	4 49.1	Near Liberty Hotel.
72	Fairfax Stoue .....	Garrett .....	39 11.679 29.2	29.2	3 16.4	At the Stone.
72A	" .....	" .....	39 11.779 29.2	29.2	3 12.4	463 feet North Sta. 72.
73	Camp Fairfax .....	" .....	39 12.779 29.0	29.0	3 13.0	Flynn's Farm.
74	Backbone Mtn. ....	" .....	39 14.179 29.2	29.2	3 14.0	Niehler Mon.
76	Foley Mtn. ....	" .....	39 20.879 30.4	30.4	3 22.8	Near Brookside, W. Va.
77	Lower Hill.....	{Western Bound	39 21.979 29.2	29.2	3 23.5	Near L. A. B. Mon.
78	Snaggy Mtn. ....	ary Line].	39 29.179 29.2	29.2	3 44.0	Near Michler Mon.
79	Taylor's Hill.....	" .....	39 30.079 30.4	30.4	3 38.5	Near Merid. Sta.
80	Fike's Hill, East .....	" .....	39 34.779 29.2	29.2	3 47.0	Near Michler Mon.
81	" " West.....	" .....	39 33.979 30.4	30.4	3 47.1	North end of Clearing.
82	Mason and Dixon Line.	" .....	39 43.379 29.2	29.2	3 54.1	273 feet north Michler Mon.
70	Corunna .....	Garrett .....	39 16.679 22.6	22.6	3 22.6	M. L., N. Mon., '97 and 1900.
24A	Oakland .....	" .....	39 24.579 24.5	24.5	3 28.8	Merid. L., S. Mon.
24	" .....	" .....	39 24.679 24.6	24.6	3 24.2	School Lot.
95	Swanton .....	" .....	39 27.079 12.3	12.3	3 38.3	W. H. Lohr's Garden.
91	Mcllenry .....	" .....	39 33.479 21.2	21.2	3 38.0	School Lot.
92	Accident.....	" .....	39 37.679 19.0	19.0	3 46.5	" "
94	New Germany .....	" .....	39 37.979 07.2	07.2	4 00.7	Otto's Farm.
93	Grantsville.....	" .....	39 41.679 09.1	09.1	4 00.1	" "
33	Belcamp .....	Harford .....	39 28.276 14.4	14.4	6 15.1	Walsh Farm.
29	Belair .....	" .....	39 31.976 20.8	20.8	5 50.3	Eagle Hotel
29A	" .....	" .....	39 31.976 20.7	20.7	4 45.1	Dallam Lot
29B	" .....	" .....	39 31.976 20.7	20.7	5 09.0	Merid. L., N. E. M. } Region Local } Dist. }
98	Havre de Grace.....	" .....	39 32.476 05.1	05.1	5 26.0	Light House.
40	Churchville .....	" .....	39 33.676 15.1	15.1	5 51.2	Garden, Forwood's Hotel.
38	Forest Hill.....	" .....	39 34.976 22.9	22.9	5 33.9	Tucker's Lot.
50	Thomas Run .....	" .....	39 35.476 16.9	16.9	5 45.8	Maj. Caldwell's Farm.
53	Minefield .....	" .....	39 39.276 22.3	22.3	7 01.6	} Loc. Dist. Not to be used.
54	Dublin .....	" .....	39 39.176 15.7	15.7	10 08.8	
52	Highland .....	" .....	39 40.576 22.1	22.1	5 41.1	Field S. Presby. Ch.
37	Cardiff .....	" .....	39 43.376 20.1	20.1	4 35.3	1896 Sta.
37B	" .....	" .....	39 43.276 20.1	20.1	8 43.4	Bound. Stone
37J	" .....	" .....	39 43.276 20.1	20.1	7 35.6	School Lot
37K	" .....	" .....	39 42.676 19.0	19.0	6 59.0	Peerless Slate Q. } Region Local } Dist. }
31	Ellicott City.....	Howard .....	39 16.276 48.2	48.2	4 53.9	School Lot.
31A	" .....	" .....	39 16.276 48.2	48.2	5 11.5	Merid. L., S. M. } Patapsco
31B	" .....	" .....	39 16.276 48.2	48.2	4 58.2	" " N. M. } Institute.
85	Lisbon .....	" .....	39 20.177 04.1	04.1	4 43.7	School Lot.
57	Chestertown.....	Kent .....	39 13.076 05.0	05.0	5 57.8	Merid. L., N. E. & S. W. Mon's.
57A	" .....	" .....	39 12.976 04.0	04.0	5 54.8	College Campus.
58	Tolchester .....	" .....	39 12.976 14.3	14.3	5 44.9	Race Track.
9	Massey .....	" .....	39 18.575 48.5	48.5	6 34.8	Near School House.
99	Betterton .....	" .....	39 21.976 03.9	03.9	4 05.5	Hill W. Betterton Hotel.
1	Linden .....	Montgomery .....	39 00.577 03.1	03.1	3 38.3	Base Station.
1A	" .....	" .....	39 00.777 03.1	03.1	3 48.3	Auxiliary Station.
42	Forest Glen .....	" .....	39 00.877 03.2	03.2	3 46.3	Lot front Cath. Church.

TABLE IX.—Concluded.

Recapitulation of all values of the magnetic declinations observed in Maryland between 1896-1901, reduced to January 1, 1900, and arranged alphabetically according to county.

No.	Station.	County.	Latitude.	Longitude.	Declination Jan. 1, 1900. (West.)	Remarks.
67	Seneca.....	Montgomery.....	39 04.877 20.6		2 38.2	'97 Sta., J. West's Field.
67A	".....	".....	39 04.877 20.7		2 32.7	99 Sta., H. " "
62	Rockville.....	".....	39 05.077 09.2		5 32.1	Field back C. H.
62A	".....	".....	39 05.077 09.0		5 44.7	Merid. L., S. Mon., Academy.
108	Hunting Hill.....	".....	39 05.877 12.5		6 09.9	I. B. Ward's Field.
109	Quince Orchard.....	".....	39 07.277 15.4		4 16.5	J. T. Higden's Field.
107	Derwood.....	".....	39 07.277 09.5		8 23.9	W. W. Stewart's Property.
84	Gaithersburg.....	".....	39 08.177 11.2		5 18.6	T. I. Fulk's Garden.
84A	".....	".....	39 08.277 12.5		5 44.0	} Different Stations } near Latitude } Observatory. } Magnetic House.
84B	".....	".....	39 08.277 12.5		5 56.0	
84C	".....	".....	39 08.277 12.5		5 28.2	
84D	".....	".....	39 08.277 12.5		6 25.9	
106	Redland.....	".....	39 08.577 08.6		6 38.8	T. F. Cashell's House.
102	Waring.....	".....	39 09.677 15.1		0 50.2	Waring's Field.
103	Middlebrook.....	".....	39 10.777 14.2		4 51.1	J. T. Buxton's Property.
104	Cross Roads, I.....	".....	39 11.477 11.6		6 04.4	Trundle's Field.
105	" " II.....	".....	39 09.877 09.3		6 10.8	B. R. Codwise's Field.
26A	Dickerson.....	".....	39 13.577 25.2		2 32.2	Dickerson Farm.
40	Unity.....	".....	39 13.777 03.5		5 45.4	Lot back Water's Store.
41	Damascus.....	".....	39 17.477 12.5		4 12.2	Dr. Lamsdale's Lot.
110B	Cheltenham.....	Prince George's.....	38 44.076 50.5		5 02.5	Magnetic Observatory.
110A	".....	".....	38 44.176 50.5		5 05.1	Mean Sta's IV, V, VI, VII.
110	".....	".....	38 44.376 51.0		4 58.2	Mean Sta's I, II, III.
2	Upper Marlboro.....	".....	38 49.076 45.2		5 08.9	C. H. Lot.
2A	".....	".....	38 49.076 45.2		5 05.1	Merid. L., S. M.
2B	".....	".....	38 49.076 45.2		5 03.5	" " N. M.
64	Kent I., S. B.....	Queen Anne's.....	38 53.976 22.0		5 28.8	Price Farm.
8	Centerville.....	".....	39 02.576 03.7		6 01.3	1896 Sta., Boy's Academy.
8A	".....	".....	39 04.076 04.0		6 01.7	Merid. Line, E. S. E. Mon.
43	Crisfield.....	Somerset.....	37 59.575 49.9		4 53.6	Near Academy.
16	Princess Anne.....	".....	38 12.475 42.5		5 14.1	1896 Sta., High School.
16A	".....	".....	38 12.475 42.5		5 15.3	Merid. Line, S. M. } High
16B	".....	".....	38 12.475 42.5		5 10.5	" " N. M. } School.
6	Leonardtown.....	St. Mary's.....	38 17.476 38.1		4 53.1	1896 Station, C. H.
6A	".....	".....	38 17.476 38.1		4 53.1	Merid. Line, S. M.
5	Mechanicsville.....	".....	38 26.676 44.7		4 53.3	Hotel Mattingly.
59	Oxford.....	Talbot.....	38 41.476 10.5		5 41.5	Beach, Sinclair's Hotel.
45	Tilghman I.....	".....	38 42.976 20.0		5 31.5	Sinclair's Field.
7A	Easton.....	".....	38 46.076 04.4		5 41.9	Fair Grounds.
7B	".....	".....	38 46.576 05.0		6 07.0	Merid. Line, Art. L. D.
68	Maryland Heights.....	Washington.....	39 19.777 43.5		4 31.3	Summit near old Fort.
68A	".....	".....	39 20.477 43.0		4 21.7	Hughes Farm.
22	Hagerstown.....	".....	39 38.477 42.8		4 43.9	Academy.
22A	".....	".....	39 38.177 44.9		4 35.4	Merid. L., N. M., Alms H.
69	Hancock.....	".....	39 41.678 10.3		4 32.2	Brosius' Field.
17	Salisbury.....	Wicomico.....	38 22.075 38.0		5 25.5	C. H. Lot; Loc. Dist.
17A	".....	".....	38 22.475 38.2		5 18.9	Merid. Line, N. and S.
18	Parsonsburg.....	".....	38 23.875 26.6		5 32.7	Lot South B. C. A. R. R. Sta.
15	Pocomoke City.....	Worcester.....	38 04.875 33.8		5 21.6	
14	Snow Hill.....	".....	38 10.575 23.8		5 13.6	C. H., Local Dist.
14A	".....	".....	38 10.175 23.8		5 22.4	Merid. L., S. M. } Race
14B	".....	".....	38 10.175 23.8		5 22.6	" " N. M. } Track.
13	Berlin.....	".....	38 19.975 13.3		5 35.1	Buckingham H. S.
12	Ocean City.....	".....	38 20.075 05.8		5 37.3	Life Saving Sta.

TABLE X.  
*Values of the magnetic elements observed in the vicinity of Maryland by the U. S. Coast and Geodetic Survey between 1896-1899 and reduced to January 1, 1900.*

No.	Station.	State.	Latitude.	Longtude W. of Gr.	Date of Obs'n.	D		I		H Horizon- tal Intensity.	Reduction to Jan. 1, 1900.			Magu. Elements in 1900.0			Observer.
						Obs'n. West. Decl'n.	Obs'd. Inclina- tion.	Obs'd. Inclina- tion.	D		I	H	W. Decl'n.	Incl'n	Hor. Int.		
1	Dagsboro . . . . .	Del.	38 32.975	15.6	1899.495	29.870	13.00	2030	+1.5	—	.8	0	5	31.370	12.20	2030	J. A. Fleming.
2	Seaford . . . . .	"	38 38.375	36.7	1899.49	...	70 12.90	2045	—	.8	0	0	...	70 12.10	2045	"	
3	Cape Henlopen . . . . .	"	38 46.775	05.2	1885.584	59.670	39.60	1985	+4.3	-21.6	-10.5	1	5	42.970	18.00	1984	J. B. Baylor.
4	Harrington . . . . .	"	38 55.175	34.9	1899.496	05.670	29.90	2000	+1.5	—	.8	0	6	07.170	29.10	2000	J. A. Fleming.
5	Dover . . . . .	"	39 09.075	31.3	1897.356	18.870	25.40	1998	+8.0	-4.0	-2	0	2	66.870	21.40	1996	O. B. French.
6	Bombay Hook . . . . .	"	39 21.575	31.0	1899.486	31.870	45.40	1973	+1.6	—	.8	0	6	33.470	44.60	1973	J. A. Fleming.
7	Newark . . . . .	"	39 41.075	44.5	1899.485	19.671	04.00	1975	+1.6	—	.8	0	5	21.271	03.20	1975	"
9	Alderson . . . . .	W. Va.	37 43.080	39.3	1898.421	58.669	01.60	2149	+4.7	-2.4	-1	2	03.868	59.20	2148	E. Smith.	
10	Pickens . . . . .	"	38 39.080	12.7	1898.512	45.870	02.70	2073	+4.5	-2.2	-1	2	50.370	00.50	2071	"	
12	Beverly . . . . .	"	38 50.579	53.4	1898.582	45.370	00.60	2047	+4.3	-2.1	-1	2	49.669	58.50	2046	"	
13	Buckhannon . . . . .	"	38 59.180	14.3	1898.508	00.070	05.80	2053	+4.5	-2.2	-1	3	04.570	03.60	2057	"	
15	Weston . . . . .	"	39 02.080	28.5	1898.512	31.370	12.80	2061	+4.5	-2.2	-1	2	35.870	10.60	2060	"	
16	Hendricks . . . . .	"	39 03.679	37.8	1898.582	55.370	17.60	2028	+4.3	-2.1	-1	2	59.670	15.50	2027	"	
19	Phillipi . . . . .	"	39 08.180	03.2	1898.573	27.070	12.00	2042	+4.3	-2.1	-1	3	31.870	09.90	2041	"	
20	Charlksburg . . . . .	"	39 16.980	19.6	1898.482	49.570	29.00	2032	+4.6	-2.3	-1	2	34.170	26.70	2031	"	
22	Grafton . . . . .	"	39 22.480	01.1	1898.563	29.070	35.60	2035	+4.3	-2.2	-1	3	33.370	23.40	2034	"	
23	Keyser . . . . .	"	39 26.978	50.4	1898.593	29.470	41.40	1998	+4.2	-2.1	-1	3	33.670	39.30	1997	"	
29	Leesburg . . . . .	Va.	39 07.077	34.0	1897.484	34.870	26.00	1953	+7.6	-3.8	-2	4	42.470	22.20	1953	"	
30	Round Hill . . . . .	"	39 08.077	46.0	1897.474	11.770	43.30	1946	+7.6	-3.8	-2	4	19.370	39.50	1944	C. H. Sinclair.	
31	Christiansburg . . . . .	"	37 08.080	23.9	1897.590	58.768	42.10	2159	+7.2	-3.6	-2	1	05.968	38.50	2157	O. B. French.	
32	Richmond . . . . .	"	37 32.677	28.0	1897.563	38.269	03.40	2124	+7.9	-4.0	-2	3	46.168	59.40	2122	J. B. Baylor.	
33	Accomac . . . . .	"	37 41.175	42.0	1897.384	44.969	25.90	2088	+7.9	-3.9	-2	4	52.869	22.00	2086	"	
34	Lexington . . . . .	"	39 47.379	26.8	1897.602	06.069	32.00	2092	+7.2	-3.6	-2	2	13.269	28.40	2090	O. B. French	
35	Charlottesville . . . . .	"	38 02.678	30.3	1897.553	21.969	41.00	2072	+7.4	-3.7	-2	3	29.369	37.30	2070	"	
36	Culpeper . . . . .	"	38 28.677	59.1	1897.541	56.670	20.20	1995	+7.4	-3.7	-2	2	04.070	16.50	1993	"	
37	Fairfax C. H . . . . .	"	38 50.677	18.5	1897.524	24.870	06.70	2047	+7.4	-3.7	-2	4	32.270	03.00	2045	"	
38	Woodstock . . . . .	"	38 52.578	31.6	1897.613	45.570	16.80	2029	+7.2	-3.6	-2	3	52.770	13.20	2027	"	
39	Cherrydale . . . . .	"	38 53.877	06.7	1896.745	09.370	42.00	1930	+9.8	-4.9	-2	5	19.170	37.1	...	E. D. Preston.	
	"	"	38 53.877	06.7	1898.625	16.770	40.20	1994	+4.1	-2.1	-1	5	20.870	38.10	1993	"	

Mean for Cherrydale, 5 20.070 37.60 1993

The following additional data for determining the amount of change in the magnetic declination from year to year has been secured since the publication of the First Report and is given here, in tabular form, for future use.

TABLE XI.

*Additional secular variation data of the magnetic declination.*

[The stations were in no case precisely identical.]

Station.	Latitude.	Longitude West of Greenwich.	Date, Year and Decimal.	Magnetic Declination.	Remarks.
Chesapeake Bay below mouth of Potomac . . . . .	37°55'	76°10'	1732	4°58' W	Walter Hoxton, on three voyages from London to Maryland. See Hansteen's <i>Magnetismus der Erde</i> , Christiania, 1819, Tafel III, p. 57. The latitudes and longitudes have been approximately assigned by me. L. A. B.
Chesapeake Bay mouth of Patuxent . . . . .	38 20	76 20	1732	4 47 W	
Ocean City . . . . .	38 20.0	75 05.8	1853.73	2 33.0 W	J. E. Hilgard, 1st Rep. p. 490, station Davis, in latitude 38° 20.4 and longitude 75° 06.4
			1896.72	5 27.5 W	
Oxford . . . . .	38 41.4	76 10.5	1707.5	5 04.0 W	Observed by L. A. Bauer as follows: Plat of Oxford 1707 gives magnetic bearings of certain streets. <sup>1</sup> Selecting the two best preserved street lines, their true directions were determined by observations on the sun June 25, 1897. Thus for <i>Tilghman Street</i> the true bearing was found to be, 66° 36' 0 E of N whereas the magnetic bearing in 1707 was, 71° E of N, hence (a) magnetic declination in 1707, 4° 24' W. For <i>Morris Street</i> the true bearing was, 22° 44' S E of S and the magnetic bearing in 1707, 17° E of S, hence (b) magnetic declination in 1707, 5° 45' W. Adopting the mean of (a) and (b), the magnetic declination for 1707.5 is 5° 04' W.
			1856.64	2 41.3 W	
			1897.48	5 33.9	
					C. A. Schott, First Report, p. 490. L. A. Bauer, Second Report Table II, Station 59.

<sup>1</sup>The following magnetic bearings are taken from "A Platt of the Town and Port of Oxford Surveyed in 1707 by Wm. Turbitt" belonging to the town of Oxford and brought to my attention by R. H. Bain, C. E., Easton. The map, which is on sheepskin, was inspected in the office of Col. Os. Tilghman, Easton, June 25, 1897. Magnetic Bearing (1707)

1st Street, now Morris Street. . . . . S 17 E.

[Leads down to Steamboat wharf past Todd's Hotel. In front of Hotel street bends, bearing given applies to street above, hence my astronomical observations were made at the corner of Morris and Tilghman streets.]

2nd Street (parallel to Morris Street). . . . . S 17 E.

Intersecting Streets:

Market	} old names. . . . . N 17 E.
Strand	
Bach	

[Tilghman is one of these streets.]

The azimuth observations were made at the corner of Morris and Tilghman Streets. The offsets on the streets in order to get the middle of street were measured on both sides by Mr. R. H. Bain and as long a line as possible secured. Impending shower interrupted further work.

L. A. B.

TABLE XI—Concluded.

*Additional secular variation data of the magnetic declination.*

[The stations were in no case precisely identical.]

Station.	Latitude.	Longitude, West of Greenwich.	Date, Year, and Decimal.	Magnetic Declination.	Remarks.
Chestertown . . . . .	39 12.9	76 04.0	1702 1897.41	5 06.0 W 5 47.0 W	Obtained by L. A. Bauer by determining on June 1, 1897 the astronomical direction of main street laid out in 1702 to run magnetically northwest and southeast. The data gave for the magnetic declination in 1702: (a) 5° 30' weight 3 (b) 3 55 " 1 (c) 5 05 " 2 5 06
Kent I. S. B. . . . .	38 53.9	76 22.0	1845.42 1897.55	2 24.3 W 5 21.4 W	T. J. Lee, First Report, p. 490. L. A. Bauer, Second Report, p. 34.
Webb . . . . .	39 05.8	76 40.5	1850.89 1868.73 1897.54	2 07.9 W 2 55.6 W 5 02.3 W	G. W. Dean, C. & G. S. Archives. C. O. Boutelle, First Rep. p. 490. L. A. Bauer, Second Report, p. 32.
Baltimore . . . . .	39 17.8	76 37.0			No additional data. See First Report, p. 473.
Maryland Heights. . .	39 20.4	77 43.0	1870.82 1897.57	2 56.0 W 4 31.3 W	C. O. Boutelle, First Report, p. 490. L. A. Bauer, Second Report, p. 32.
Havre de Grace. . . .	39 32.4	76 05.1	1847.51 1899.47	2 13.7 W 5 24.4 W	T. J. Lee, First Report, p. 490 (Susq. Lt.) L. A. Bauer, Second Report, Table IV, Station 98.
Western Boundary of Maryland. . . . .	39 36.7	79 29.2	1860.5 1897.77	1 23.0 W 3 42.4 W	J. de la Camp, mean of 9 stations, with small Schmalkalder compass. <sup>2</sup> L. A. Bauer, combining stations Nos. 78, 80 and 82, Table III.

<sup>2</sup> *Magnetic Declinations Observed in July, 1860 along the Michler Meridian Line.*

These readings were made presumably by the surveyor John de la Camp who cites them in his printed pamphlet addressed to the Senate of West Virginia in February, 1868. They were made on the line and doubtless with the Schmalkalder compass in the outfit of the surveying party. *No evidence can be had as to the correctness of the pointings or as to the error of the compass.* The latitudes and longitudes were assigned with the aid of the distances given in the last column.

Location.	Latitude.	Longitude.	Magnetic Declination.	Distance from Fairfax Stone, miles.
Near Clisholm's Mill. . . . .	39° 19' .1	79° 29' .2	1° 00' W	8.6
Near Cranesville. . . . .	39 33 .4	79 29 .2	1 25	25.0
On Fike's Hill. . . . .	39 34 .8	79 29 .2	1 10	26.6
5 miles north of Fike's Hill. . . . .	39 39 .2	79 29 .2	1 15	31.6
5 miles south of Pennsylvania line. . . . .	39 38 .9	79 29 .2	1 32	31.3
4 miles south of Pennsylvania line. . . . .	39 39 .8	79 29 .2	1 30	32.3
3 miles south of Pennsylvania line. . . . .	39 40 .7	79 29 .2	1 30	33.3
2½ miles south of Pennsylvania line. . . . .	39 41 .1	79 29 .2	1 35	33.8
Intersecting with Mason and Dixon line . . . . .	39 43 .3	79 29 .2	1 30	36.3
Mean. . . . .	39 36 .7	79 29 .2	1 23.0	

MAP OF THE LINES OF EQUAL MAGNETIC DECLINATION FOR  
JANUARY 1, 1900.

[Plate II.]

The present map supersedes the preliminary one published in the First Report and is based on all observations up to the present time—about three times as many as for the first publication. The lines have been drawn again with a free hand to conform as nearly as possible with the observed values of the magnetic declination.

As was to be expected, in the region of uniform distribution, viz., in the southern, southeastern and western parts of Maryland, the preliminary lines required scarcely any modification, even where the number of the stations has been greatly increased, as was the case in western Maryland. In the central and northeastern parts, however, the greatly increased number of stations necessitated material changes. Even now, owing to the greatly disturbed character of the distribution of the earth's magnetism in this region, it should not be understood that the present lines represent the actual facts in every particular. They serve, however, to point out the extent and general character of the disturbances.

The pronounced disturbance in the vicinity of Gaithersburg revealed itself when members of the Coast and Geodetic Survey made observations in various localities, near Washington, for the purpose of determining the most suitable site for a Magnetic Observatory. Plate III exhibits, on a larger scale, the isogonies, or lines of equal magnetic declination, for this locality. Gaithersburg appears to be right in the midst of the disturbance, the extreme values of the magnetic elements occurring on either side; thus at Waring, about 3 miles northwest, the declination is  $0^{\circ}50.'2$  W, the dip,  $71^{\circ}45.'6$ , the horizontal intensity 0.1880 c. g. s. units, and at Derwood, about three miles southeast, the declination is  $8^{\circ}23.'9$  W, the dip,  $70^{\circ}16.'5$  and the horizontal intensity, 0.2038.

A mathematical analysis of the forces producing the disturbances in this locality traces their source to parallel ridges running approxi-



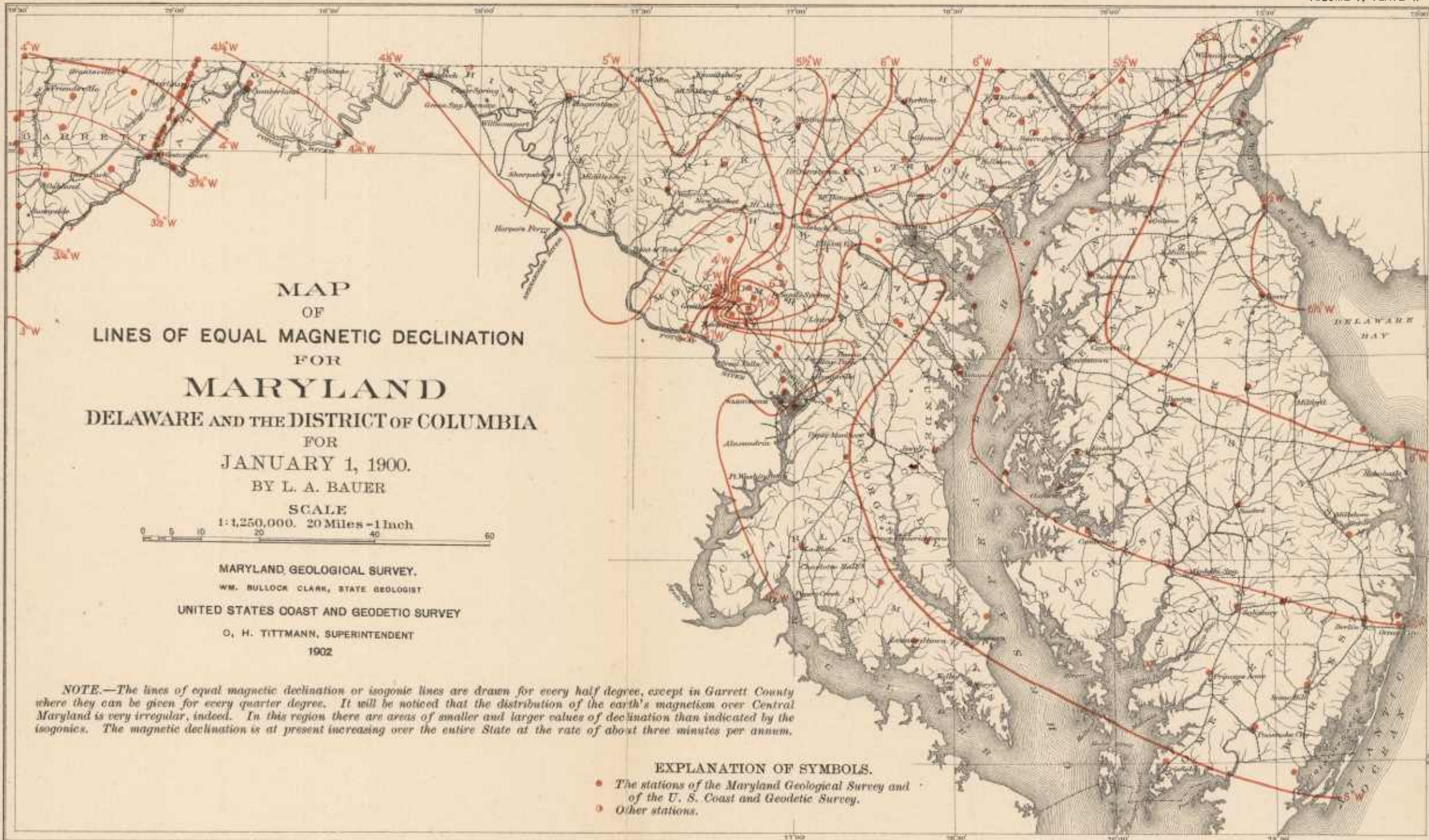

P. 44 B

P. 44 B



R. H. C.

414

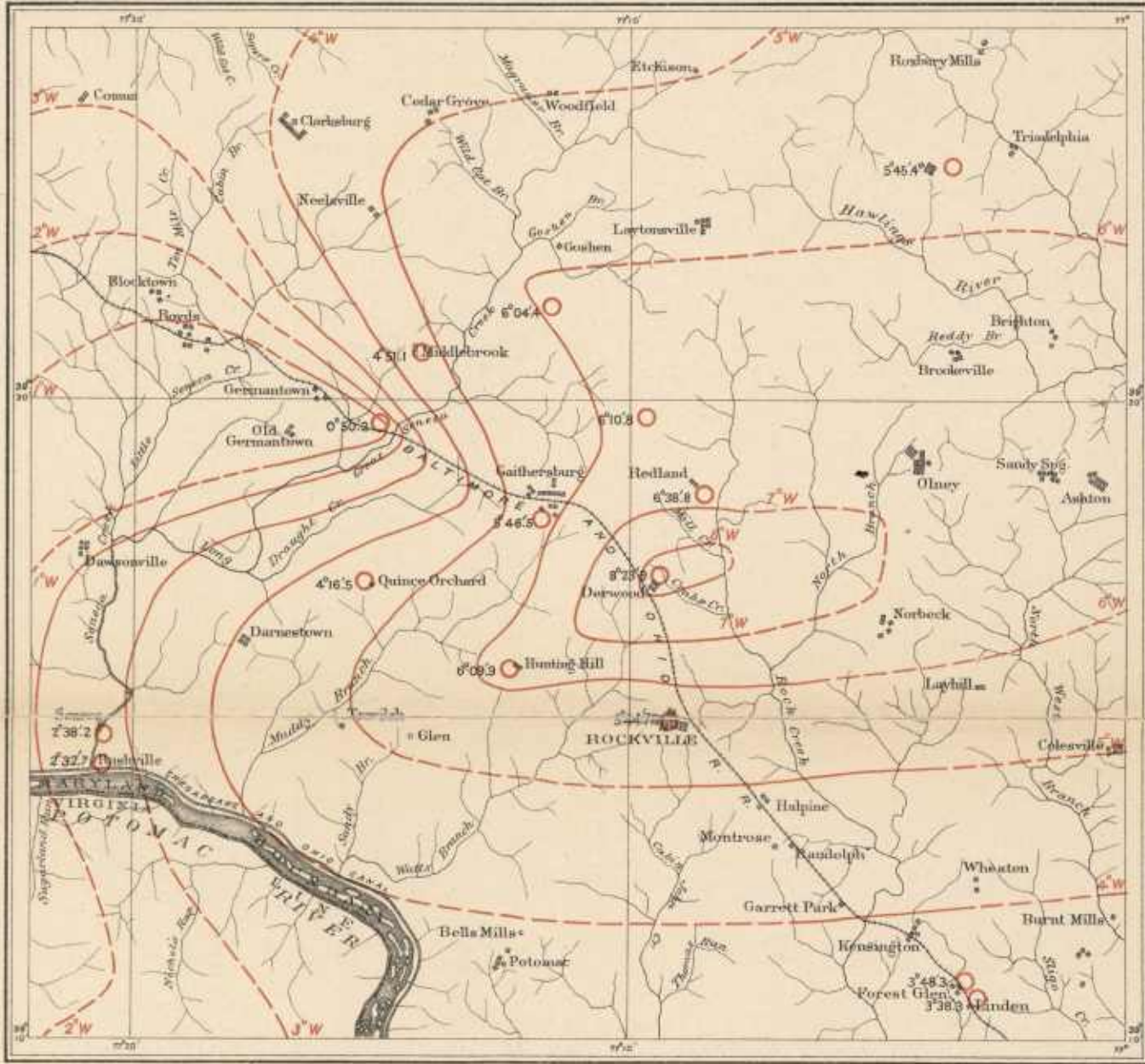

LINE OF EQUAL MAGNETIC DECLINATION IN NEIGHBORHOOD OF GAITHERSBURG, MD., FOR JAN. 1, 1900.

mately in a northeast and southwest direction, and as this direction agrees with that of the serpentine beds, as mapped by the geologists, the inference would be that these beds, as in the northeastern part of Maryland, are the cause of the magnetic disturbances.

For an account of the change in the distribution of the magnetic declination with the lapse of time, the reader is referred to pages 494-497 of the First Report where there is given an approximate representation of the distribution for the years 1700 and 1800.

*As already stated, the magnetic declination is at present increasing at the rate of 3' per year.*

#### DESCRIPTIONS OF MAGNETIC STATIONS IN MARYLAND.

##### MAGNETIC STATIONS IN MARYLAND BETWEEN 1896 AND 1901.

The arrangement of the stations is alphabetical. The number indicates the general order in which the stations were occupied, and at the same time serves as a brief method of designating the various stations. When an additional station was obtained in the same town or locality a capital letter is attached to the number.

All the stations were temporarily marked at the time of observation by wooden stubs with brass nails or screws in their tops. These stubs were left in the ground. No money was available, except when meridian lines were established, for marking the stations more permanently, nor was it particularly advisable, except in a few cases, to spend any great amount of time or money in this way. The descriptions below will, in general, suffice for future observations at the identical station and they include all stations obtained from the beginning of the magnetic survey in 1896 to 1901. At a few of the stations no declinations were observed for various reasons.

92. ACCIDENT, GARRETT COUNTY, 1899.—In the south corner of school lot opposite Bellevue Hotel. Marked by a stake which is 62.9 feet from east corner of frame school house and 93.7 feet from west corner.

30. ANNAPOLIS, ANNE ARUNDEL COUNTY, 1896.—On the Naval Academy grounds, in the open area near the Observatory; 45 paces west-northwest of Observatory and 62 paces northeast of Herndon Monument. Site was

chosen by Professor Terry, in charge of the Physical Department of the Academy.

30A and B. ANNAPOLIS, ANNE ARUNDEL COUNTY, 1900. Observations were made over both ends of the meridian line located on the Naval Academy grounds in the large open space south of the Naval Cemetery. The North stone is 93 feet from the Cemetery Road, 190 feet from the Severn County Road and about 300 feet from the south stone.

32. BALTIMORE, FORT MCHENRY.—The description furnished by the Coast and Geodetic Survey of their station occupied in 1895 by J. B. Baylor, Assistant, is as follows: New station selected is in the large open space in the extreme eastern part of the Fort next to the outer sea-wall;  $16\frac{1}{2}$  yards from the outer sea-wall and 13 yards from a locust tree, and is marked by a substantial locust post with a copper tack in it, and sunk flush with ground. Site is quite free of artificial disturbing influences, such as pipes, ordnance materials, etc.

The Magnetic Survey station, 1896, was placed as near as possible to above station. The locust post could not be found, but with the aid of the orderly who had assisted Mr. Baylor, it was possible to locate within a few feet of Mr. Baylor's station.

[The former C. and G. S. station of 1877 and 1885 in another part of the grounds had to be abandoned on account of proximity of electric cars. The commander of the Fort states that there was a bed of iron below the grounds of the Fort.]

66. BAY RIDGE, ANNE ARUNDEL COUNTY, 1897.—In the field south of summer resort. Only dip observations were made.

29. BELAIR, HARFORD COUNTY, 1896.—In the garden back of Rouse House, known later as Eagle Hotel; 110 paces back of the house, 41 paces north of south barbed-wire fence and 34 paces west of east fence at a point where stands a small willow tree. Site appears to be free from any artificial disturbing influence.

29A and B. BELAIR, HARFORD COUNTY, 1897.—When establishing a true northeast and southwest line, observations were made at various points in the vicinity of the court-house; station 29B is over the Northeast monument and is subject to artificial local disturbance. The 1896 station back of the hotel was also reoccupied and a new station, 29A, established in the Dallam lot, back of the jail. Belair is in the midst of great regional disturbances and a small change in the position of the station will produce large changes in the magnetic elements. Compare, *e. g.*, the declinations for 29 and 29A, two stations not over one-quarter of a mile apart.

33. BELCAMP, HARFORD COUNTY, 1896.—On the farm belonging to Mr. James Walsh and occupied at present by Mr. E. J. Cottle, about 400 feet back of railroad station, 34 paces west of first locust tree, 25 paces south of wild cherry tree.

13. BERLIN, WORCESTER COUNTY, 1896.—In the northwest corner of Buckingham High School grounds; 61.2 feet from the northwest corner of the

frame building and 21.8 feet (at right angles) from the fence in the rear of grounds.

99. BETTERTON, KENT COUNTY, 1899.—Station is on the hill west of Betterton Hotel owned by Mr. John Henry Crew. Precise spot is in line with chestnut tree, on the northeast side of the hill, and the northeast corner of Mr. Crew's house, about  $\frac{1}{8}$  of the way from said tree. Point is marked by a wooden peg.

56. BRADSHAW, BALTIMORE COUNTY, 1897.—On the grounds of Col. Taylor, east of the Baltimore and Ohio station, 25 paces south-southeast of locust tree.

4. BRANDYWINE, PRINCE GEORGE'S COUNTY, 1896.—In the woods about 100 yards east of railroad station. Dip only observed. Soil, sandy.

101. CALVERT, CECIL COUNTY, 1899.—Station is near the southeastern corner of school lot, about in line with the eastern edge of school and 16 paces north of large oak.

44. CAMBRIDGE, DORCHESTER COUNTY, 1897.—In the grounds on the south side of the court-house, over the Southeast monument of the true northwest-southeast line established in 1897. This monument owing to the nature of the soil and of the surroundings had to be placed on the grounds adjacent to the court-house lot and owned by Mr. James Wallace. Water was struck about three feet below the surface. This monument is a granite post, 7 x 7 inches square and  $4\frac{1}{2}$  feet long, projecting about 8 inches above the ground and having in its center a brass bolt with a cross cut in to mark the northwest-southeast line. The Northwest monument is a similar pillar and is fully 350 feet away. There may be a slight local disturbance near the latter owing to vicinity of court-house. The Southwest monument is doubtless free from local attraction, near the jail, however, a decided local disturbing influence makes itself felt.

37. CARDIFF, HARFORD COUNTY, 1896.—In the open lot about 100 yards southeast of railroad station; 32 paces from the white wooden fence and 8 paces from wire fence.

37A-K. CARDIFF, HARFORD COUNTY, 1897.—Region of serpentine quarries. In 1897, 11 additional stations in this vicinity were occupied for the purpose of mapping the disturbed area. At most of the additional stations simply the dip was observed.

37A. Was in the baseball field southwest of the station near the Slate Ridge church.

37B. On mine hill (serpentine rocks) about 27 feet west of State Boundary Stone (date 1774).

37C. In South Delta. Over a quartz boulder in Wm. Ramsey's field and west of the railroad track about 400 feet.

37D. Dip circle placed directly on the serpentine rocks of quarry opposite railroad station.

37E. On the hill east of track, near slate quarry.

37F. About one-quarter of a mile west of railroad station and near the Pennsylvania line.

37G. At Whiteford Postoffice. On top of Mr. Whiteford's serpentine quarry. According to Mr. C. Whiteford, surveyor, the slate ridge runs about south 50° 30' west and the serpentine rocks about parallel to the slate ridge.

37H. On the property of Caroline Flaherty about one-quarter of a mile north-northeast of station 37G.

37I. At Cambria and about one mile south of station. Hole nearby from which iron ore was obtained and which shows the contact of slate and sandstones.

37J. Cardiff schoolhouse lot. The station is in the back lot and is marked by a hole cut in the largest gray stone sticking out of the ground.

37K. On the property of the Peerless Slate Quarry, about one mile east of Cardiff.

8. CENTERVILLE, QUEEN ANNE'S COUNTY, 1896.—In the grounds of the Centerville Academy for boys, about one-eighth of a mile east of court-house; 62 feet south of south corner of Academy and 44 feet west of young sycamore tree. Soil, sand and clay.

8A. CENTERVILLE, QUEEN ANNE'S COUNTY, 1897.—When establishing a true west-northwest and east-southeast line in 1897, the station of 1896 was reoccupied. Station 8A is over the East-southeast monument and is subject to artificial local disturbance.

110 and 110A. CHELTENHAM, PRINCE GEORGE'S COUNTY, 1899.—I. On the grounds of the Reform School about 50 feet due north of farm house; II. On the grounds of the Reform School about 226 paces west of the old Hospital and about 1314 feet south-southwest of I; III. On the grounds of the Reform School about 1641 feet southwest of I and about 985 feet west-northwest of II; IV. About 1 mile magnetically north of the Reform School on the property of the Barbour heirs, at present occupied by Mr. Harrison; V. About  $1\frac{1}{3}$  mile magnetically south of the Reform School on the property of Mr. Wm. Saccor, at present occupied by Mr. F. Peacock; VI. About  $1\frac{1}{4}$  mile magnetically west of Reform School, in the third meadow from Mr. Hill's house; VII. About 1 mile magnetically east of Reform School in Mr. E. G. Ellis' field.

110B. CHELTENHAM, PRINCE GEORGE'S COUNTY, 1901.—At the U. S. Coast and Geodetic Survey Magnetic Observatory.

57 and 57A. CHESTERTOWN, KENT COUNTY, 1897.—A true northeast-southwest line was marked permanently in 1897 on the grounds of the court-house. As there exists at this place a small artificial local attraction another station (57A), in the grounds of Washington College was occupied in order to obtain the corrections for the court-house station; 57A is the magnetic station adopted.



49. CHURCHVILLE, HARFORD COUNTY, 1897.—In the orchard back of Churchville hotel owned by Laurenee Forwood and between the first two apple trees.

19. COCKEYSVILLE, BALTIMORE COUNTY, 1896.—On Mr. Coekey's property, a large, open lot on right of road near stone bridge. Station is about 500 feet west of road and 25 feet east of a clump of three willow trees.

70. CORUNNA, GARRETT COUNTY, 1897 and 1900.—On Mr. W. McCulloh Brown's estate south of Oakland. Precise point was over the North monument of the meridian line established by L. A. Bauer in 1897.

35. CRESWELL, HARFORD COUNTY, 1896.—About half-way between Creswell and Fountain Green on the road to Belair, about one-sixth of a mile from Winchester crossing on a small triangular plat opposite Mr. W. H. Michael's place; about four miles from Belair. Only dip was observed.

44. CRISFIELD, SOMERSET COUNTY, 1896.—In the large, open lot west of the Academy on 12th and ——— Street; 60 paces from southwest corner of Academy (a frame building) in a line with rear side of Academy.

101. CROSS ROADS I, MONTGOMERY COUNTY, 1899.—The station is in a wheat field belonging to Mr. Trundle and occupied by Mr. E. L. Hain, 84 paces from nearest corner of tobacco house and 48 paces from road. Tobacco house is 330 paces from creek.

106. CROSS ROADS II, MONTGOMERY COUNTY, 1899.—The station is located in a large open field belonging to Mr. B. R. Codwise, 39 paces from road and 195 paces south by southwest of a tree near center of field.

23. CUMBERLAND, ALLEGANY COUNTY, 1896.—In the large, open arca on Camp Hill, north of Rose Hill Cemetery and south of Wills Creek. To find station, go 75 paces along the north iron fence of cemetery, starting from northeast corner, then 75 paces at right angles towards Wills Creek. According to town map, this area is subdivided into lots and streets, but no sign of the latter on the ground at present. Station may have been between Sedgwick and Niagara Streets. According to the map it is about 4667 feet due west of middle point of Decatur Street, on which Mosman's astronomical and magnetic stations of 1864 were located. Station is also about 2744 feet west of court-house and about 1280 feet north, and may possibly be over a cement mine. Site was selected in the absence of the County Surveyor by Thomas L. Patterson.

23A. CUMBERLAND, ALLEGANY COUNTY, 1897.—At the South Meridian Stone of the County Meridian Line on the Poor House Farm, established by L. A. Bauer in 1897. [For further information, see the Allegany County Report, pp. 253-262.]

41. DAMASCUS, MONTGOMERY COUNTY, 1896.—On Dr. Lansdale's lot, 18 paces from west corner and 42 paces from small house at east corner.

132 and 132A. DENTON, CAROLINE COUNTY, 1900.—Observations were made over both ends of the meridian line which is located in the court-house yard. The North stone, 132A, is 55 feet east of the fence of the jail-yard.

The South stone, station 132, is 260 feet from the North stone and 2 feet north of the edge of the walk along the south side of the square.

108. DERWOOD, MONTGOMERY COUNTY, 1899.—This station is on the property of Mr. W. W. Stewart, occupied by Mr. H. E. Clark, 62½ paces from a cherry tree on the edge of the road and 65½ paces from the northeastern corner of the barn in field.

26. DICKERSON, MONTGOMERY COUNTY, 1896 and 1900.—Station of 1896 was on Mr. Dickerson's farm directly north of railroad depot, in the direction towards Sugarloaf Mountain, near a clump of locust trees about 500 feet from depot, 27 paces west of locust trees about 18 paces south of wooden fence. The station of 1900 is near that of 1896.

54. DUBLIN, HARFORD COUNTY, 1897.—The station was in the field back of the hotel and was purposely placed on the largest gabbro rock jutting out of the ground; the desire being to ascertain the effect from such rocks. It will be seen that the elements are disturbed, the declination, for example, being about 4° too high. *The surveyor should make no use of the values given for this place.*

7. EASTON, TALBOT COUNTY, 1896.—In the northeast corner of the garden on the east side of Avon Hotel, 45 feet west of east wooden fence, 26 feet south of north wooden fence and 74 feet north of large willow tree. Soil, sand and loam. This station, because of artificial local disturbance, has been abandoned.

7A and B. EASTON, TALBOT COUNTY, 1897.—When establishing the meridian line in 1897, magnetic observations were made at various points. The station 7A which is located in the Fair Grounds outside the city is the one adopted in the Magnetic Survey. Station 7B is over the monument in the court-house grounds and is subject to artificial local disturbance.

31. ELLICOTT CITY, HOWARD COUNTY, 1896.—In the grounds back of public school up on the hill near the court-house and west of old Patapsco Institute; 40 paces back of frame school building near oak tree and 7 paces north of south wooden fence.

31A and B. ELLICOTT CITY, HOWARD COUNTY, 1900.—Observations were made on both ends of the meridian line on the grounds of the Patapsco Institute on the hill, a short distance from the court-house. The north stone (31B) is 22 feet from the north fence and 88 feet from the west fence. Station 31A is over the South stone.

27. ELKTON, CECIL COUNTY, 1896.—In the south corner of grounds around new high school building just nearing completion; about 49 paces from the nearest edge of building, 13 paces from fence in the rear and 11 paces from fence on the side.

27A and B. ELKTON, CECIL COUNTY, 1900.—The station 27A is the South stone of the meridian line in the high school grounds. It is 36 feet from the west fence, 34.5 feet from the south fence and about 270 feet from the north stone, station 27B.



60. FAIR HAVEN, ANNE ARUNDEL COUNTY, 1897.—On the hill not far from the steamboat landing.

42. FOREST GLEN, MONTGOMERY COUNTY, 1896.—On the grass plat under maple tree east of road directly in front of Catholic cemetery.

38. FOREST HILL, HARFORD COUNTY, 1896.—In the large, open lot of Messrs. E. Tucker & Co., west of railroad depot; 200 paces from fence corner nearest the depot and 46 paces east-northeast of cherry tree.

36. FOUNTAIN GREEN, HARFORD COUNTY, 1896.—In large open field on Mr. Grant's place; about 200 feet west of store at corner of road and about 25 feet from the middle of the road to Belair; about two miles east of Belair. Only dip was observed.

20. FREDERICK, FREDERICK COUNTY, 1896. *First Station*.—In the southeast part of the grounds back of the State Deaf and Dumb Asylum. Marked by two stakes, one  $1\frac{1}{4} \times 1\frac{1}{4} \times 8$  inches, and another four feet west  $\frac{1}{2} \times 2 \times 8$  inches; the former marks the station and was driven flush with the ground; the station is 26 paces north of the south hedge fence and 34 paces from southeast corner of hedge fence. This station is the preferable one.

20A. FREDERICK, FREDERICK COUNTY, *Second Station*, 1896.—North meridian stone in the grounds on the side east of the courthouse—subject to artificial local disturbance.

84. GAITHERSBURG, MONTGOMERY COUNTY, 1899.—Same as Mr. Edwin Smith's station of 1898 and described by him as follows: "The station is immediately in front of Mr. T. I. Fulk's farm house. The point is marked with a stone below surface of ground with a cross on it."

84A, B and C. GAITHERSBURG, MONTGOMERY COUNTY, 1899.—The three magnetic stations here are on that part of the property of Mr. T. I. Fulks, occupied by the International Geodetic Association for the purpose of making latitude observations. Station I (84A) is northeast by east of a large chestnut tree to north of Observatory plat by 96.1 feet, while station II (84B) is in the same azimuth ( $24^{\circ} 01'$  W. of S.) with I and ridge of eastern end of roof of small shed of Mr. Johnson (colored). Station III (84C) is in line with chestnut tree about at right angles to line of I and II and about 15 feet north of southern line of plat.

84D. GAITHERSBURG, MONTGOMERY COUNTY, 1900-1901.—The small magnetic house erected by the U. S. Coast and Geodetic Survey near the International Geodetic Association Observatory (see 84A).

93. GRANTSVILLE, GARRETT COUNTY, 1899.—Near the west corner of schoolhouse lot, opposite Farmers' Hotel. Marked by a cherry stake,  $2 \times 2$  inches square; with brass screw in the top, and having a pine stake driven alongside as a wedge. This stake is 69.25 feet from east corner of schoolhouse and 32.8 feet from second locust tree east of gate of entrance to school.

22. HAGERSTOWN, WASHINGTON COUNTY, 1896.—In the grounds on the east side of the Hagerstown Academy, down on the slope near the second maple tree on the right-hand side of path to railroad station. The tracks of Western Maryland railroad are about 300 feet to the west and those of the Cumberland railroad about 500 feet to the east. Site was chosen by the County Surveyor, Mr. Piper. Marked by an ash stave which broke off when driven. Limestone rocks crop out of the ground.

22A. HAGERSTOWN, WASHINGTON COUNTY, 1900.—The station is the North stone of the U. S. Geological Survey meridian line on the almshouse farm about  $1\frac{3}{4}$  miles north of the city. The stone is 296.5 feet east of the schoolhouse and 4 feet south of the fence line. The mark or range used was the lightning rod on the square tower of the almshouse and bears  $20^{\circ} 26.2'$  east of true south.

34. HARFORD FURNACE, HARFORD COUNTY, 1896.—About one-fifth of a mile from the village along the road to Belair; on Mr. A. H. Strausbaugh's farm, 15 paces from the road and opposite "hay bag" on Mrs. Mary D. Walsh's estate. Only dip was observed.

98. HAVRE DE GRACE, HARFORD COUNTY, 1899.—Station is on the grounds between the Havre de Grace light and the light-keeper's house, about in line with light and porch of house and 26 paces east of house. Precise point is a  $\frac{1}{2}$ -inch hole drilled in a solid stone flush with the ground, which at one time formed the northwest pier of a small dwelling. There is a similar stone 7 paces south, another 8 paces east and still another 13 paces east.

51. HICKORY, HARFORD COUNTY, 1897.—On Mr. Thomas Poole's field, opposite Mrs. A. C. Grafton's millinery store and 33 paces from the road. Only the dip was observed.

52. HIGHLAND, HARFORD COUNTY, 1897.—In the field south of the Presbyterian Church.

109. HUNTING, HILL, MONTGOMERY COUNTY, 1899.—Station is on the wheat field of Mr. I. B. Ward north of road, 280.2 feet from northeast corner of Mr. Ward's store and 381 feet from southwest corner of his barn and stable.

11. HURLOCK, DORCHESTER COUNTY, 1896.—Directly in front of frame schoolhouse on the right-hand side of road to East Newmarket; near the road. Soil, sandy.

48. HYDES, BALTIMORE COUNTY, 1897.—On Mr. Hyde's tract back of garden behind the store and railroad office, about 125 paces west of railroad track.

64. KENT ISLAND, QUEEN ANNE'S COUNTY, 1897.—Near the so-called South Base station of 1845 (see pp. 490 and 505, First Report). The 1897 station is in the field west of old dwelling house on the old Price farm. The farm is now owned by the National Bank of Centerville and the present tenant

is Mr. Palmer. The precise point is 100 paces southwest of present entrance to dwelling-house, 39 paces from southwest corner of garden fence and 45 paces north of row of three pear trees. The site of the monument<sup>1</sup> marking the South Base station in 1845 is now about  $\frac{1}{2}$  or  $\frac{3}{4}$  mile in the Chesapeake Bay.

65. KENT ISLAND. STEVENSVILLE, QUEEN ANNE'S COUNTY, 1897.—In the field of the brick church opposite Lowry's Hotel, 75 paces in direction of cherry tree. Tent stake was left standing. On account of rain no meridian could be determined, hence, the magnetic declination was not obtained.

3. LA PLATA, CHARLES COUNTY, 1896 and 1897.—In the northwest corner of new court-house grounds, 40 feet southeast of northwest corner-stone of lot and 28 feet south of locust (?) tree and 49 paces northwest of northwest corner of new court-house just nearing completion. Marked by an oak stub with a brass screw. There was no fence around the lot at this time. Soil sandy.

When establishing the meridian line in 1897 in the west grounds of the court-house yard, observations were made at various points and no appreciable local attraction found. The adopted station is the South monument. The 1896 station is now covered by a wooden fence surrounding the grounds.

6. LEONARDTOWN, ST. MARY'S COUNTY, 1896.—In the southwest corner of the court-house lot, 92 feet from southwest corner of court-house and  $23\frac{1}{4}$  feet from southwest corner post of wooden fence. Soil, sand and loam.

6A. LEONARDTOWN, ST. MARY'S COUNTY, 1900.—The station is the South end of the meridian line in the court-house square. It is 9 feet from the wooden fence on south side and 9 feet from west wooden fence. The North stone is about 300 feet distant.

[The granite pillar marking the South Base geodetic station when it was on the point of being washed away was removed by Mr. Alfred Price and put in his front yard and used as a carriage step. In 1897 I found it still there, the inscription on one side being "U. S. Survey of the Coast," on the other the date "1844" is given. The copper plug in the top had been removed by someone and the top of the stone mutilated, a corner being broken off. I also found a large slate stone with a copper bolt in the center which was being used as a kitchen step. Likewise as a step to the front entrance (porch) was a small, smooth granite stone about 10-12 inches square at the base and the top tapering to a point. The apex of the stone was turned down and the flat, bottom side used as the step. Height of stone was about 10 inches. Mr. Norman, 65 years of age, told me that he sat on the S. B. stone in 1860 waiting for the "Great Eastern" to come up the Bay. The stone was then about 25 yards from the water.—L. A. B., July 19, 1897.]

61. LAUREL, PRINCE GEORGE'S COUNTY, 1897.—In the field beyond iron bridge, about  $\frac{1}{4}$  mile from depot and south of first house beyond bridge. No declination observations were obtainable because of cloudy weather.

90. LIBERTYTOWN, FREDERICK COUNTY, 1899.—In the large lot back of schoolhouse opposite Liberty Hotel. The precise point is marked by a solid stub 167.9 feet from north front of schoolhouse, 46.35 feet from northwest corner of small house, 33.35 feet from east fence, and 25.5 from line of locust trees on the west side.

1. LINDEN, BASE STATION, MONTGOMERY COUNTY, 1896-1901.—In the middle of Professor M. H. Doolittle's rear garden, 94.1 feet northwest of northeast corner of frame dwelling-house and 84.1 feet northeast of northwest corner of same house. Station was marked originally by a brass screw in a 2" x 4" x 2 $\frac{1}{2}$ ' yellow pine stub projecting four inches above ground. The primary azimuth mark was the extreme tip of the Chevy Chase standpipe, three miles distant; subsequently, because of growth of trees hiding monument from view, a secondary mark had to be utilized.

This important station was permanently marked in 1897 by a sandstone post, 6 x 6 inches square projecting out of the ground about six inches. A small hole drilled in the middle of the stone marks the precise point.

1A. LINDEN, MONTGOMERY COUNTY, 1896.—In large vacant lot back of base station; about 300 paces nearly due north of base station, 34 feet north of fence of Dr. Wright's Sanitarium and 44 feet southeast of the stile. Now (1901) the site is occupied by houses.

85. LISBON, HOWARD COUNTY, 1899.—Near the southwest corner of schoolhouse lot; a graveyard adjoins the lot. The precise point is 19.3 feet from the west fence (wood), 23.6 feet from the south fence (wood) and 79.3 feet from the southwest corner of schoolhouse, a frame one-story building.

83. LONACONING, ALLEGANY COUNTY, 1898.—In the south part of baseball field south of Maryland Coal Company's office. The precise point is marked by a locust stake and can be pointed out by Mr. F. E. Brackett, Superintendent of the Coal Company.

88. MANCHESTER, CARROLL COUNTY, 1899.—In the lot back of the schoolhouse and the Methodist Church; 37 feet east of large cherry tree and 104.3 feet from northwest corner of schoolhouse. Marked by a tent peg.

68. MARYLAND HEIGHTS, WASHINGTON COUNTY, 1897.—At extreme southern end of fort, in a small open space at end of path leading south from highest point of fort. [It was not easy to find the old C. & G. S. station of 1870 (see pp. 490 and 505, First Report). According to present indications it would seem to fall in a thicket of trees. I therefore chose the best site available at the time.—L. A. B., July 27-'97.]

68A. MARYLAND HEIGHTS, HUGHES FARM, WASHINGTON COUNTY, 1897.—In the little apple orchard back of Mr. Hughes house, 46 feet in line with south garden fence and 42 feet from west garden fence.

9. MASSEY, KENT COUNTY, 1896.—On the north side of road to Clayton near small schoolhouse, about one mile from railroad station; 121 feet north-northwest of northwest corner of schoolhouse.
91. MCHENRY, GARRETT COUNTY, 1899.—Over red sandstone rock in lot south of frame schoolhouse, directly north of Mr. Brison Welsh's house. The point is marked by a  $\frac{1}{2}$ -inch hole drilled in the rock 57.7 feet from southwest corner of schoolhouse and 66.8 feet from southeast corner.
5. MECHANICSVILLE, ST. MARY'S COUNTY, 1896.—In the garden of Hotel Mattingly, 18 feet northeast of mulberry tree and  $9\frac{1}{2}$  feet west of wooden fence. Dip station  $5\frac{1}{2}$  feet north of mulberry tree. Soil, sand and loam.
104. MIDDLEBROOK, MONTGOMERY COUNTY, 1899.—The station is on the property of Mr. J. T. Buxton to the east of the road to Gaithersburg and 37 and 67 paces respectively to the south of old chimney of the ruins of a house built in 1800, and from chimney of present house.
53. MINEFIELD, HARFORD COUNTY, 1897.—Near Rigdon's abandoned iron ore mines. The purpose of making observations at this disturbed place was to ascertain the amount of disturbance.
94. NEW GERMANY, GARRETT COUNTY, 1897.—On Mr. J. C. Otto's farm; in the meadow about 300 feet east of house and about 25 yards east of garden. Precise point is marked by a  $\frac{1}{2}$ -inch hole drilled in large flat sandstone sticking out of the ground. There is another stone about 10 feet west.
24. OAKLAND, GARRETT COUNTY, 1896.—In the lot back of new public school, 60 paces north of latter, 20 paces from east board fence, 16 paces east of oak tree along west fence and 17 paces southwest of large oak tree near north fence.
- 24A. OAKLAND, GARRETT COUNTY, 1897.—In the court-house yard over the South monument of the meridian line established by L. A. Bauer in 1897.
12. OCEAN CITY, WORCESTER COUNTY, 1896.—Near Life Saving Station, 200 paces north and 200 paces west, in large, open, sandy area north of Bruce Cottage, northeast of schoolhouse, between Baltimore and Philadelphia Avenues.
59. OXFORD, TALBOT COUNTY, 1897.—The station was on the beach in front of Sinclair's Hotel and is near Mr. Schott's station of 1856 (see First Report, pp. 490 and 506).
97. PARKTON, BALTIMORE COUNTY, 1897.—On top of the hill west of the railroad station and over the first boundary stone marking the property of the railroad company. This boundary stone is on the hill about 20 yards north of wooden fence leading up the hill.
18. PARSONSBURG, WICOMICO COUNTY, 1896.—In open lot, 170 paces south of Baltimore, Chesapeake and Atlantic railroad station; lot owned by pro-

prietor of saw-mill opposite station. Soil, black clay. Natural gas in vicinity.

15. POCOMOKE CITY, WORCESTER COUNTY, 1896.—In the northeast part of the grounds about the Academy; 36 paces west of Academy, 11 paces west of east hedge fence and 25 paces south of north hedge fence.

25. POINT OF ROCKS, FREDERICK COUNTY, 1896.—About one-sixth mile to the west-northwest of Junction Depot on the knoll on Mr. E. W. Mercer's property back of Mr. H. B. Carter's house to the west of depot. Site of former ore mines, ore being found 40-60 feet below ground. East of station is a sunken shaft of an abandoned ore mine; station is 15 paces west of bank of this shaft and 8 feet south of a projecting boulder.

16. PRINCESS ANNE, SOMERSET COUNTY, 1896.—In the southeast part of the spacious grounds around the new high school building; 62 paces southeast of entrance to school, 40 paces north of large oak tree in southeast corner of lot, 10 paces west of east fence. These grounds have been the site of a schoolhouse for about 100 years.

16A and B. PRINCESS ANNE, SOMERSET COUNTY, 1900.—Observations were made over both ends of the meridian line which is located in the high school grounds. The South stone, 16A, is 55 feet from the south fence, 95 feet from the east fence and about 350 feet from the North stone, 16B.

28. PRINCE FREDERICK, CALVERT COUNTY, 1896.—In the grounds of the court-house, between its southwest corner and small frame building occupied at the time by a shoemaker; 15 paces north of latter building and 25 paces due east of wooden structure used as a jail. The road-bed of proposed Drum Point railroad is about 200 feet to the west.

28A and B. PRINCE FREDERICK, CALVERT COUNTY, 1900.—Observations were made over both ends of the meridian line located in the court-house square. The South stone, 28A, is 13.8 feet from the south fence, 33.3 feet from the east fence and about 200 feet from the North stone, 28B.

110. QUINCE ORCHARD, MONTGOMERY COUNTY, 1899.—This station is in the field of Mr. John T. Higden, north of road, 116 paces from a small apple tree at the road fence and 67 paces from corner of fence to the west.

107. REDLAND, MONTGOMERY COUNTY, 1899.—This station is near the road in an open field belonging to Mr. Thomas F. Cashell, 136 paces from large oak tree in middle of field and 46 paces measuring in line of large cherry tree on the side of road to fence.

87. REISTERSTOWN, BALTIMORE COUNTY, 1899.—In the large open field west of the Franklin School.

10. RIDGELY, CAROLINE COUNTY, 1896.—On the grounds in the rear of frame schoolhouse, corner First Street and First Avenue west; 53 feet west of southwest corner of rear extension of schoolhouse and 31½ feet east of young maple tree. Soil, sand, clay and gravel.

100. RISING SUN, CECIL COUNTY, 1899.—Station is in Mr. H. J. Briscoe's field near the north corner of fence and east of railroad station. Precise point was marked by a tent peg.

62. ROCKVILLE, MONTGOMERY COUNTY, 1897.—In middle of field back of court-house owned by Mr. Rabbitt and leased by Mr. Poss who keeps a livery stable.

62A. ROCKVILLE, MONTGOMERY COUNTY, 1900.—Observations were made over the South meridian stone in the Academy grounds distant 41 feet from the south fence and 93 feet from the west fence. The North meridian stone is 21.5 feet from the north fence and 96 feet from the west fence.

17. SALISBURY, WICOMICO COUNTY, 1896. *First Station*.—On the grounds in front of the court-house; on the right-hand side of walk to entrance of court-house, about 14 feet south of south edge of this walk and 20 feet east of east edge of pavement. Brick buildings rather close. The second station should be given preference.

17A. SALISBURY, WICOMICO COUNTY. *Second Station*.—On the grounds of Mr. Thomas Humphreys, attorney-at-law, about 175 yards southeast of the court-house on the opposite side of "Lake" Humphreys. This is the site of the county meridian line established in 1896. Observations were made over the South monument and likewise 16 feet east of North monument. Site was chosen by Mr. Peter Shockley, County Surveyor.

55. SCARBORO, HANFORD COUNTY, 1897.—In the field, south of Mr. Halley's store; only the dip was observed.

67. SENECA, MONTGOMERY COUNTY, 1897.—In the large field belonging to Mr. John West, and northeast of crossing of Canal over Seneca Creek. The station is 150 paces from the road and northeast of Mr. George Good's house and near the south one of the two oak trees.

67A. SENECA, MONTGOMERY COUNTY, 1899.—This station is on the wheat field of Mr. H. West near the point where the Chesapeake and Ohio Canal crosses Seneca Creek, being several hundred feet removed from each of these, 84 paces east of a large walnut tree and 97 paces southwest of a post near the corner of the field.

14. SNOW HILL, WORCESTER COUNTY, 1896.—In the southwest corner of the court-house lot; 61.8 feet from southwest corner of court-house,  $6\frac{1}{2}$  feet west of large sycamore tree. Soil, sandy. No fence around the lot, simply a stone curb. Station is 21.2 feet north of south curb and 15.2 feet east of west curb. The station was too near to buildings and has therefore been abandoned.

14A and B. SNOW HILL, WORCESTER COUNTY, 1900.—Observations were made over both the meridian stones of the meridian line which is located in the circular race-track just east of the town and the railway station.

The South stone, 14A, is 135 feet north of the south fence and 295 feet east of the west fence of the race-track property. The North stone, 14B, is about 300 feet from the South stone.

39. STABLER, MONTGOMERY COUNTY, 1896.—On Mr. Warwick P. Miller's farm, near Spencerville, in the open field between Mr. Miller's dwelling-house and that of Mr. Asa Stabler. This station was established in 1869 by Mr. C. O. Boutelle, Assistant of the Coast and Geodetic Survey, and is marked by a hole drilled in a large quartz boulder projecting slightly above the ground. With the aid of Mr. Miller, who had assisted Mr. Boutelle, the identical spot was found in 1896. The trigonometrical station is 232 metres (761 feet) nearly due south of magnetic station, is marked by five stone monuments projecting a few inches above the ground. The bearing of the central monument from the magnetic station was  $4^{\circ} 53'.3$  west of south, according to Mr. Boutelle. In 1896 Mr. L. A. Bauer, from a single solar azimuth observations, found the same bearing to be  $4^{\circ} 53'.6$ .

95. SWANTON, GARRETT COUNTY, 1899.—In the southeast corner of garden in front of Mr. W. H. Lohr's frame dwelling used as a boarding-house. Precise point is marked by a nail in a stake driven in an old stump.

86. SYKESVILLE, CARROLL COUNTY, 1899.—The station is in the large open field, about 300 feet back of the new brick school.

89. TANEYTOWN, CARROLL COUNTY, 1899.—In the yard back of Professor Henry Meier's Academy; 307 feet from west fence, 19.2 from east fence and 62.8 from north corner of small frame house. Professor Meier proposed to mark the station permanently.

50. THOMAS RUN, HARFORD COUNTY, 1897.—On the farm of Major Caldwell of Baltimore City, leased at present by Mr. John Lochary; 30 paces from the fence along main road and opposite the blacksmith's shop.

45. TILGHMAN ISLAND, TALBOT COUNTY, 1897.—In Mr. B. B. Sinclair's field back of Mrs. Lee's hotel about 1 mile nearly north of the landing of the Baltimore, Chesapeake and Atlantic railway steamers; about 20 paces east of Mrs. Lee's back fence and same distance south of road on the north side of Mrs. Lee's grounds. The island is about  $\frac{1}{2}$  mile wide at this point and the station is just about midway. The steamboat landing is on the east side of the Island.

58. TOLCHESTER, KENT COUNTY, 1897.—In the race-track field back of the picnic grounds.

47 and 47A. TOWSON, BALTIMORE COUNTY, 1897.—In the ample grounds on the west side of the court-house. A meridian line was established at the time and marked by substantial granite posts. The observations were made over these posts, the north one being station 47 and the south one, 47A.



40. UNITY, MONTGOMERY COUNTY, 1896.—In the lot back of stable adjacent to Mr. Water's store, rented at present by Mr. Schwartz; 26 paces east of Mr. Schwartz's milk-house and 50 paces southwest of Mr. Clay Brown's brick house.

2. UPPER MARLBORO, PRINCE GEORGE'S COUNTY, 1896.—In the southeast corner of the court-house grounds, down in the hollow; 13.9 feet west of maple tree and 88 feet from southeast corner of court-house; marked by a round  $1\frac{1}{4}$ -inch pine stub with a brass tack. Soil, sandy. Dip was observed, 18 feet, magnetic north-northeast of main station.

2A and B. UPPER MARLBORO, PRINCE GEORGE'S COUNTY, 1900.—The South meridian stone, 2A, is in the Academy grounds 75 feet from the front door of the Academy building and 58 feet from the fence on the street. The North meridian stone, 2B, is also in the grounds of the Academy, on the edge of the bluff. From the South stone the cupola of the Southern Maryland Bank bears  $42^{\circ} 58'$  east of true south.

103. WARING, MONTGOMERY COUNTY, 1899.—Station is located in wheat field of the Waring heirs, near the ruins of a dwelling destroyed by fire, some 330 feet from the public road and 500 feet from fence along railroad cut, about in line with western fence of garden plot and 110 feet distant from large thorn tree in northwest corner of garden.

63. WEBB, ANNE ARUNDEL COUNTY, 1897.—Near the 1897 scaffold of the triangulation station, about  $94\frac{1}{2}$  feet southeast from granite post marking the station. This is near the site of Boutelle's magnetic station of 1868 (see First Report, pp. 490 and 508).

71. WESTERNPORT, ALLEGANY COUNTY, 1897.—The station is on north side of hill along road leading down the river from West Virginia Central railroad station and about 100 yards east of last house.

21. WESTMINSTER, CARROLL COUNTY, 1896.—In the grounds back of court-house about 22 paces west of back entrance near edge of pavement. Site not a good one and accordingly has been abandoned.

21A and B. WESTMINSTER, CARROLL COUNTY, 1900.—Observations were made over both ends of the meridian line located in the grounds of the Western Maryland College, about one mile north of the court-house. The South stone, 21A, is in the athletic grounds 60 feet from a garden fence and 65 feet from a small wooden stable. The North stone, 21B, is near the northern boundary of the college property. From the South stone the spire of the German Reformed church bears  $12^{\circ} 35'$  west of true north.

46. WOODSTOCK, HOWARD COUNTY, 1897.—In the grounds of the Woodstock College directly in front of the main building, near the tennis courts; 30 feet south of elm tree and marked by a broken tent peg. Observations for magnetic declination were not obtainable.

WESTERN BOUNDARY OF MARYLAND STATIONS OF 1897, ALONG THE  
" FAIRFAX " MERIDIAN LINE.

72 and 72A. FAIRFAX STONE.—This stone was the initial point of the Michler survey of the Western Boundary Line and is situated at one of the head springs of the North Branch of the Potomac river. The original Fairfax Stone planted in 1745 has disappeared since the Michler survey (1859) and instead is a monument about three to four feet high, which Lieut. Michler stated he placed directly behind the Fairfax Stone and used as a pier for his instrument. The magnetic observations were made partly a few feet north of the stone but mainly, however, at a point 463 feet north (72A).

73. CAMP FAIRFAX.—Near the barn on Mr. Patrick Flynn's farm situated east of the Michler line and between the Fairfax and the Backbone monuments.

74. BACKBONE MOUNTAIN.—On the summit of the Backbone or Big Savage Mountain near the Michler monument, a monument built of dressed stones and about 4 feet high. The precise point was about 11 feet south of the monument, which is about 15,000 feet north of the Fairfax Stone and approximately 3323 feet above sea-level.

77. LOWER HILL.—A few feet north of stone with a copper bolt in it, projecting about a foot above the ground, the stone having been planted by L. A. Bauer in 1897 to mark his meridian line. A few feet east is a pile of stones placed by Lieut. Michler in 1859.

78. SNAGGY MOUNTAIN.—The magnetic station is marked by a hole drilled in a rock 78.85 feet nearly north of Michler monument.

80. FIKE'S HILL.—The magnetic station was 30 feet a little west of north from the Michler monument.

82. MASON AND DIXON.—The magnetic observations were made at a point in the field 273 feet north of the Michler monument, which marks the intersection of the Michler meridian line with the Pennsylvania or Mason and Dixon line.

WESTERN BOUNDARY OF MARYLAND STATIONS OF 1897, ALONG THE  
" POTOMAC " MERIDIAN LINE.

75. CAMP POTOMAC.—On the Backbone Mountain where it is crossed by the meridian line traced by L. A. Bauer in 1897 which starts at the Potomac Stone placed by W. McCulloh Brown in 1897. The precise point is 49.6 feet north of the Potomac Stone. The Potomac meridian is one and one-eighth miles west of the Fairfax meridian.

76. FOLEY MOUNTAIN.—Near Brookside, W. Va. The station is on the top of the mountain in the clearing for the meridian line 22.05 feet,  $35^{\circ} 01.2'$  west of north from L. A. Bauer's meridian station.

79. TAYLOR'S HILL.—The magnetic station is 51.3 feet north-northwest of meridian station.

81. FIKE'S HILL.—North of a large flat rock at north end of clearing for the meridian line.

DESCRIPTIONS OF RECENT MAGNETIC STATIONS IN THE VICINITY OF  
MARYLAND OCCUPIED BY THE U. S. COAST AND GEODETIC SURVEY.

DELAWARE.

6. BOMBAY HOOK, KENT COUNTY, 1899.—Station is in cornfield on beach in line of Duck Creek Light and Woodland Beach Hotel buildings, about 500 feet south of a stunted tree near hightide line and about  $\frac{1}{8}$  mile from hotel. The ground is owned by the Smith heirs and has been occupied for some time by a colored man, Samuel F. Loatman. This position is in the near neighborhood of the station occupied by Locke in 1846.

1. DAGSBORO, SUSSEX COUNTY, 1899.—Station is quite close to old station of 1856 occupied by Mr. C. A. Schott of the U. S. Coast and Geodetic Survey, being 110 yards back of road on a line at right angles to road between second and third house from Lingo to Lingo's store and about 100 yards back of peach tree on said line and pointed out as the site of hotel owned by Mr. Smith<sup>1</sup> and 500 yards north of Pepper Creek Ditch bridge. Property is owned by Mr. R. D. Lingo.

4. HARRINGTON, KENT COUNTY, 1899.—Station is in northwest corner of white public school, being south of north fence by 19.6 feet and distant from northwest corner post 28.6 feet. Precise point is marked by a tent peg.

7. NEWARK, NEW CASTLE COUNTY, 1899.—Station is on farm of the Lewis heirs, three-quarters of a mile from depot and occupied by Mr. E. M. Lewis. It is south of Delaware Avenue, about 350 feet, and east of South College Avenue, about 400 feet. Precise point is shown by a stake.

2. SEAFORD, SUSSEX COUNTY, 1899.—Station is in public school lot, 35.9 feet from west fence and 52.9 feet distant from south-west corner post. Precise point is marked by tent peg.

VIRGINIA.

33. ACCOMAC, ACCOMAC COUNTY.—Station is in a large open lot just west of the court-house square, near the southern edge of same and near the

<sup>1</sup> This hotel is referred to in Mr. Schott's description of old station.

road. It is marked by a heavy granite post lettered U. S. C. S., with small copper bolt marking point. Post projects above ground by 4 inches and is the southern one of two marking the meridian.

35. CHARLOTTESVILLE, ALBEMARLE COUNTY.—Station is near north end of Athletic grounds of the University of Virginia; it is nearly south 27 meters from granite post lettered U. S. C. S. and in line with it and first chimney visible to the right of the University Museum and just appearing above the surface of the ground under the trees in the University grounds.

39. CHERRYDALE, ALEXANDRIA COUNTY.—Station is near residence of Mr. E. D. Preston of the Coast and Geodetic Survey, being about 140 feet east of same.

31. CHRISTIANSBURG, MONTGOMERY COUNTY.—Station is near summit of the ridge just south of the railroad station and near road or lane which extends up the ridge from a point about 100 meters east of the railroad station and about 20 feet from north meridian stone in the line of Presbyterian white church spire west of court-house.

36. CULPEPER, CULPEPER COUNTY.—Station is located in the Southern railroad stock-yards about  $\frac{1}{2}$  mile east of the town of Culpeper and north of the Southern railroad tracks. Station is slightly north of the summit of the ridge which is a little south of the center of the lot and is 17 meters east of a granite post marked U. S. C. S.

37. FAIRFAX, FAIRFAX COUNTY.—Station is located near the southwest corner of the grounds surrounding the court-house and other county buildings; it is marked by a granite post 6" x 6" on its top lettered U. S. C. S. read looking north.

29. LEESBURG, LOUDOUN COUNTY.—Station is in the north end of the playground on the west side of the Leesburg Academy—nearly due north of the building; about 20 feet from the fence north and 60 feet from fence east.

32. RICHMOND, HENRICO COUNTY.—Station is in "New Reservoir Park," in southwestern section of the city near the river, in open space just south of the Lake; marked by a heavy granite post sunk 5 feet into the ground, top dressed 4 inches square, marked U. S. C. S., with a small copper bolt marking the point. Post projects above ground by 4 inches and is the southern one of the two marking the meridian.

20. ROUND HILL, LOUDOUN COUNTY.—Station is in pasture field of Mr. Lodge, who owns the store nearest to the depot. Field is on north side of the railroad, and station is to north of field about 33 feet south of the stone fence and 246 feet northwest of flour mill. Marked by a locust stub.

38. WOODSTOCK, SHENANDOAH COUNTY.—Station is located near the north end of lot within the race-track at the fair grounds and 13 meters from north meridian stone marked U. S. C. S. on a line 28° south of west.

## WEST VIRGINIA.

9. ALDERSON, MONROE COUNTY.—Station is located on grounds of the Allegheny Collegiate Institute on the south side of High Street, between Church and Monroe Streets; it is marked by a sandstone post projecting 3 or 4 inches above the ground and the precise point is marked by a copper bolt.

12. BEVERLY, RANDOLPH COUNTY.—Station is in the south end of the town in the yard of Dr. H. Yokum on the west side of the main street and is marked by a heavy sandstone post in which is set a copper bolt which is also the southern mark of meridian line, the north end of which is likewise marked on the east side of the main street 350 feet distant.

13. BUCKHANNON, UPSHUR COUNTY.—Station is located in the grounds of the West Virginia Conference Seminary (Methodist Church), at northwest corner of the lot. It is marked by a blue sandstone post and copper bolt which also marks north end of meridian line, and is about 450 feet north of south meridian post.

20. CLARKSBURG, HARRISON COUNTY.—Station is marked by a copper bolt in southern sandstone post of meridian line, 170 feet east of public school building in play-ground of same.

22. GRAFTON, TAYLOR COUNTY.—Station is located on a hill near a large rock which is a prominent object; it is almost south of the railroad depot. Station is known to Mr. Jno. E. Slone of this place, and is a few hundred feet from meridian established by the U. S. Geological Survey.

69. HANCOCK, WASHINGTON COUNTY, 1897.—In the large open field north of railroad depot belonging to Mr. Brosius.

16. HENDRICKS, TUCKER COUNTY.—Station is on land owned by the U. S. Leather Company, about 1000 feet beyond Little Block Fork River bridge and on the north side of the road. It is about 1200 feet southwest of West Virginia Central railroad and the same distance from Dry Fork railroad. Is marked by a cross on a natural rock.

25. KEYSER, MINERAL COUNTY.—Station is in the lawn of the house on the hill belonging to Mr. W. E. Crooks, marked by a sandstone post and copper bolt.

96. PAW PAW, MOROAN COUNTY, 1899.—This station had to be placed in West Virginia as it was not easily possible to cross the river into Maryland with the magnetic outfit. It is in the large field south of railroad station, near the frame dwelling-house on the hill. The precise point is marked by a stake 37 feet from northwest corner of fence (wood), 67 feet from northeast corner and 29 feet in front of gate. The house was occupied at the time by D. G. Bevans.

19. PHILIPPI, BARBOUR COUNTY.—Station is in the southern part of the town on a street running nearly east and west, on land owned by C. A. W. Smith, being the third lot from Main Street. It is marked by a copper bolt set in the north sandstone post of the meridian line, distant about 2000 feet from a similar post marking south end of line in northwest corner of a lot owned by the Hon. G. A. Dayton.

11. PICKENS, RANDOLPH COUNTY. Station is about  $\frac{1}{4}$  mile east of railroad, and 100 feet north of road running east from depot on land belonging to James Pickens, and back of a house owned by W. R. Thomas; marked by a copper bolt set in a triangular rock.

15. WESTON, LEWIS COUNTY.—Station is at the south post of meridian line in front of the south wing of the main building of the West Virginia Hospital and 230 feet west of the railroad; marked by copper bolt in blue sandstone post.

THE DISTRIBUTION OF THE MAGNETIC INCLINATION OR DIP FOR  
JANUARY 1, 1900.

Plate IV.

EXPLANATORY REMARKS AS TO ISOCLINIC MAP, METHODS OF OBSERVING  
AND REDUCING.

In the First Report, pp. 413-418, the magnetic inclination is defined and a brief account of the principal phenomena is given, while on p. 452, a description and a view (Plate XV, Fig. 2) of the instrument used in the observations will be found. Plate XVI, of the same Report contained the preliminary lines of equal magnetic inclination for January 1, 1897, as based upon the 1896 work. The present map (Plate IV), however, is based on all of the observations, the graphical method of constructing the lines having been again adopted.

The general method of making dip observations in use in the Coast and Geodetic Survey,<sup>1</sup> with but slight modification, was employed. The dip-circle is known as 56/4440, and at the time it was loaned to the Maryland Geological Survey (before the writer had charge of the magnetic work of the Coast and Geodetic Survey), it had but one needle that gave satisfactory results. Accordingly this needle, known as No. 1, was almost exclusively used and when occasionally

<sup>1</sup> See Appendix No. 8, Report of the U. S. Coast and Geodetic Survey for 1881.



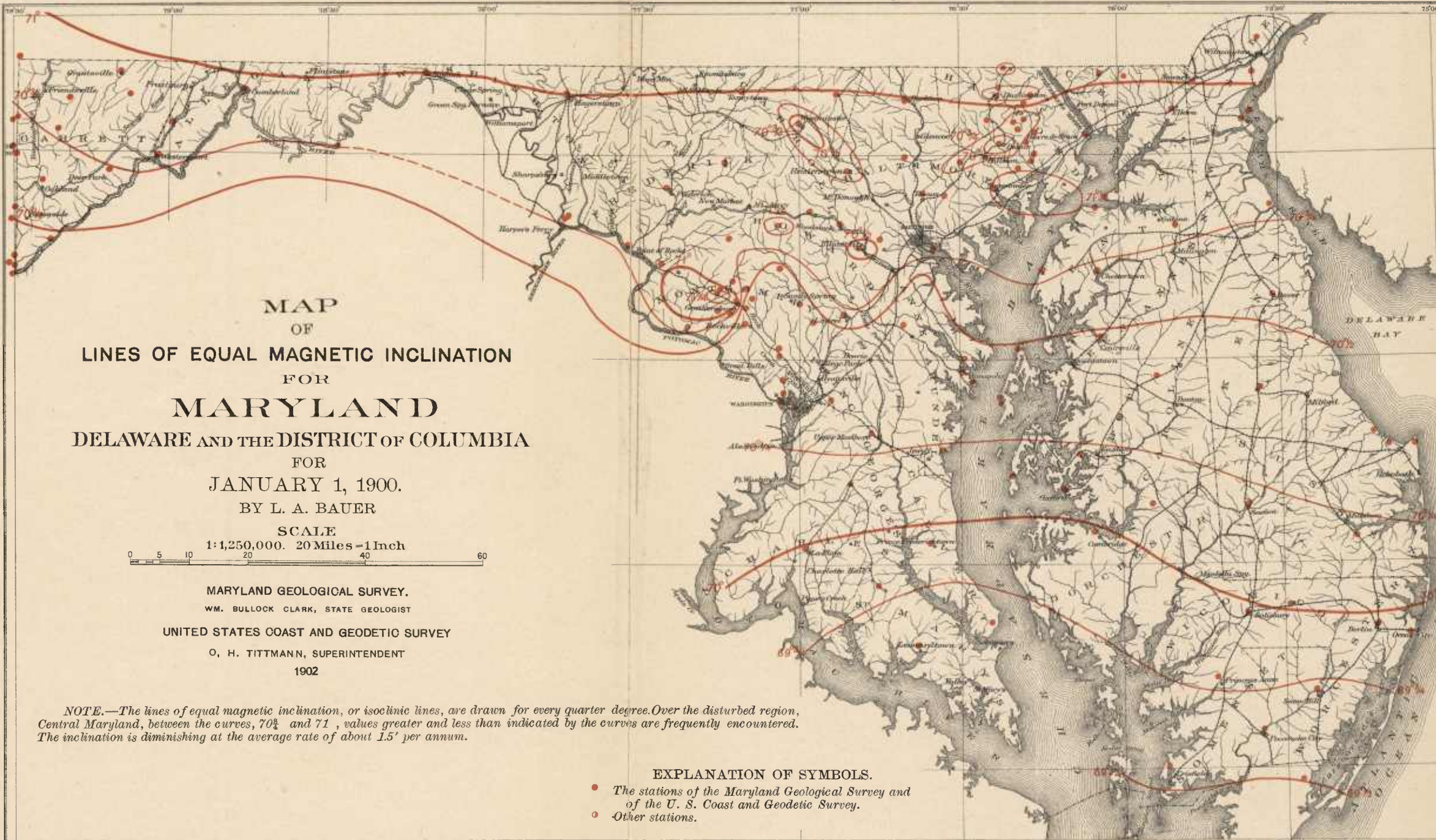

MAP  
OF  
LINES OF EQUAL MAGNETIC INCLINATION  
FOR  
**MARYLAND**  
DELAWARE AND THE DISTRICT OF COLUMBIA  
FOR  
JANUARY 1, 1900.

BY L. A. BAUER

SCALE  
1:1,250,000. 20 Miles = 1 Inch

MARYLAND GEOLOGICAL SURVEY.  
WM. BULLOCK CLARK, STATE GEOLOGIST  
UNITED STATES COAST AND GEODETIC SURVEY  
O. H. TITTMANN, SUPERINTENDENT  
1902

*NOTE.*—The lines of equal magnetic inclination, or isoclinic lines, are drawn for every quarter degree. Over the disturbed region, Central Maryland, between the curves, 70½ and 71, values greater and less than indicated by the curves are frequently encountered. The inclination is diminishing at the average rate of about 1.5' per annum.

EXPLANATION OF SYMBOLS.

- The stations of the Maryland Geological Survey and of the U. S. Coast and Geodetic Survey.
- Other stations.

P. 64 B

P. 64 B

some other needle was employed the result obtained with it was referred to No. 1. The method of observation gave two independent results, which are designated in the tables as I and II.

At all stations, except in special investigations of locally disturbed areas, the polarity of the needle was reversed.

The reduction to mean of day, January 1, 1900, had to be made, as in the case of the declination, without the use of a magnetic observatory. The repeat observations made at Linden, the base station, as given in Table XIV; combined with those of the Coast and Geodetic Survey in the vicinity of Maryland gave *an average annual decrease of the magnetic inclination of 1'.5*. Reduction to mean of day was made with the aid of the continuous observations obtained at the Magnetic Observatory of the United States Naval Observatory *before* it was removed to its present disturbed site, viz., from 1889-1892.

The tables of the diurnal variation of the inclination were not given, however, in the publications of the Observatory, hence they had to be deduced from a combination of the following two tables, Table XI, which gives the diurnal variations of the horizontal intensity, and Table XII, the same for the vertical intensity. The tabular quantities are expressed in units of the fifth decimal, c. g. s. units, which unit, following the suggestion of Eschenhagen, is called a gamma and is designated by the Greek letter,  $\gamma$ —the g sound reminding one of the name of Gauss. Table XIII gives the corrections to be applied to an observed inclination to refer it to the mean value for the day (24 hours).



TABLE XI.

*Diurnal variation of the horizontal intensity of the earth's magnetic force as derived from the continuous observations of the Washington Magnetic Observatory between the years 1889-1891, in units of the fifth decimal C. G. S. system.*

The hours given are for the 75 Meridian Mean Time which is 8m. 12s. fast on local mean time. Plus sign of tabular quantities means less, and minus sign greater than mean of day, hence the table gives the corrections to be applied to an observed quantity to obtain the mean value of the day.

Month.	Year.	HOUR.																							
		A. M.												P. M.											
		1	2	3	4	5	6	7	8	9	10	11	12	1	2	3	4	5	6	7	8	9	10	11	12
Jan. . .	1890	0	-1	-1	-3	-3	-3	-5	-6	-5	+2	+12	+17	+10	+5	0	-3	-6	-6	-3	-2	0	0	0	0
	1891	0	-2	-4	-6	-8	-9	-9	-10	-7	+4	+19	+24	+17	+9	+1	-5	-5	-4	-3	-1	-2	-1	0	0
	1892	-4	-4	-5	-9	-8	-7	-9	-6	-3	+14	+26	+25	+17	+9	+2	-3	-4	-7	-5	-2	-2	-1	-2	-4
	Mean.	-1	-2	-3	-6	-6	-6	-8	-7	-5	+7	+19	+22	+15	+8	+1	-4	-5	-6	-4	-2	-1	-1	-1	-1
Feb. . .	1889	0	0	-2	-3	-3	-5	-7	-5	-4	+2	+6	+10	+9	+7	+4	-1	-5	-2	-2	+1	+1	+1	+2	+1
	1890	+1	-1	0	-1	-1	-2	-4	-5	-3	0	+5	+10	+10	+3	-1	-1	0	0	+1	0	+1	0	-1	0
	1891	+2	-3	-3	-5	-7	-9	-9	-6	-1	+2	+9	+11	+11	+9	+6	+1	0	-3	-2	0	0	0	0	-1
	Mean.	+1	-1	-2	-3	-4	-5	-7	-5	-3	+1	+7	+10	+10	+6	+3	0	-2	-2	-1	0	+1	0	0	0
March.	1889	-1	-3	-2	-3	-4	-4	-4	0	+6	+11	+9	+10	+4	+1	-4	-5	-4	0	-1	-2	-2	0	-2	-1
	1890	-4	-2	-3	-4	-6	-5	-4	+1	+5	+14	+15	+14	+7	+2	-1	-3	-3	0	0	-1	-1	-3	-4	-3
	1891	-6	-7	-6	-7	-10	-8	-7	-3	+5	+10	+10	+10	+10	+6	-1	-2	-1	+1	+5	+3	0	-4	-1	-6
	Mean.	-4	-4	-4	-5	-7	-6	-5	-1	+5	+12	+11	+11	+7	+3	-2	-3	-5	0	+1	0	-1	-2	-2	-3
Apr. . .	1889	-4	-4	-4	-4	-5	-6	-2	+3	+12	+15	+13	+7	+1	-4	-5	-4	-5	-2	0	-2	-1	+2	+1	-2
	1890	-2	-2	-2	-3	-4	-3	-1	+8	+17	+19	+16	+11	+2	-4	-8	-9	-9	-7	-2	-3	-3	-4	-4	-2
	1891	-7	-6	-7	-9	-9	-7	-4	+3	+13	+23	+25	+10	+11	+3	-7	-10	-6	-4	-1	-5	-6	-6	-5	-6
	Mean.	-4	-4	-4	-5	-6	-5	-2	+5	+14	+19	+18	+9	+5	-2	-7	-8	-7	-4	-1	-3	-3	-3	-3	-3
May. . .	1889	-2	-2	-2	-2	-3	-5	-1	+6	+18	+22	+14	+4	-6	-11	-11	-6	-5	-2	-2	-2	-1	-1	-2	-1
	1890	-1	0	0	-1	-1	-1	+1	+7	+17	+20	+15	+4	-6	-11	-10	-8	-5	-2	0	0	-3	-1	-1	-1
	1891	+2	-1	-4	-4	-2	-5	+2	+13	+23	+24	+14	+2	-10	-13	-14	-11	-5	-2	-2	+1	+5	-2	+1	-1
	Mean.	0	-1	-2	-2	-2	-4	+1	+9	+19	+22	+14	+3	-7	-12	-12	-8	-5	-2	-1	0	0	-1	-1	-1
June. . .	1889	-1	-1	-2	-1	-3	-4	0	+6	+14	+18	+14	+6	-1	-7	-9	-9	-3	-2	-1	-1	-3	-2	-3	-1
	1890	-1	0	+1	0	0	-3	-2	+5	+14	+19	+15	+9	-3	-8	-8	-9	-6	-4	-1	-1	-4	-3	-2	0
	1891	-1	-1	-1	0	-2	-3	0	+9	+15	+17	+12	+4	-5	-13	-17	-15	-8	-3	0	+2	0	0	-2	0
	Mean.	-1	-1	-1	0	-2	-3	-1	+7	+14	+18	+14	+6	-3	-9	-11	-11	-6	-3	-1	0	-2	-1	-2	0

TABLE XI—Concluded.

*Diurnal variation of the horizontal intensity of the earth's magnetic force as derived from the continuous observations of the Washington Magnetic Observatory between the years 1889-1891, in units of the fifth decimal C. G. S. system.*

The hours given are for the 75 Meridian Mean Time which is 8m. 12s. fast on local mean time. Plus sign of tabular quantities means less, and minus sign greater than mean of day, hence the table gives the corrections to be applied to an observed quantity to obtain the mean value of the day.

Month	Year.	HOUR.																							
		A. M.												P. M.											
		1	2	3	4	5	6	7	8	9	10	11	12	1	2	3	4	5	6	7	8	9	10	11	11
July..	1889	-3	-3	-5	-1	-2	-3	-1	+5	+12	+18	+18	+13	+5	-2	-5	-7	-6	-3	-3	-1	-2	-3	-3	-3
	1890	-3	0	-2	0	-2	-3	0	+8	+18	+22	+19	+7	-4	-10	-11	-10	-7	-4	-5	-4	-3	-3	-2	-3
	1891	-2	-1	0	0	-1	-4	-2	+5	+15	+20	+17	+8	-5	-10	-15	-15	-9	-2	+2	+3	+1	+1	+1	0
	Mean.	-3	-1	-2	0	-2	-3	-1	+6	+15	+20	+18	+9	-1	-7	-10	-11	-7	-3	-2	-1	-1	-2	-1	-2
Aug..	1889	-6	-3	-3	-2	-3	-5	-2	+7	+18	+23	+19	+9	+1	-6	-8	-6	-3	-3	-2	-3	-4	-2	-2	-4
	1890	-7	-6	-5	-4	-6	-5	-1	+12	+24	+24	+19	+10	+2	-5	-7	-7	-5	-4	-6	-5	-5	-6	-5	
	1891	-4	-5	-5	-4	-5	-6	-3	+10	+22	+26	+21	+11	-2	-9	-14	-12	-8	-3	+1	-3	-2	-4	0	-3
	Mean.	-6	-5	-4	-3	-5	-5	-2	+10	+21	+24	+20	+10	0	-7	-10	-8	-5	-4	-2	-4	-4	-4	-3	-4
Sept..	1889	-3	-5	-4	-6	-6	-5	-4	+7	+16	+21	+22	+12	+5	-1	-5	-5	-4	-1	-4	-2	-5	-4	-5	-4
	1880	-4	-6	-4	-6	-8	-7	-4	+5	+16	+21	+20	+14	+6	-1	-5	-5	-5	-4	-2	-2	-3	-5	-4	-5
	1891	-6	-6	-7	-7	-10	-8	-4	+8	+19	+26	+24	+19	+7	-2	-9	-12	-5	-4	-3	-5	-5	-4	-6	-6
	Mean.	-4	-6	-5	-6	-8	-7	-4	+7	+17	+23	+22	+15	+6	-1	-6	-7	-5	-3	-3	-3	-4	-4	-5	-5
Oct..	1889	-3	-3	-4	-6	-6	-7	-3	+3	+10	+13	+13	+11	+5	+2	-1	-2	+1	-1	-1	-1	-1	-2	-2	-2
	1890	-7	-7	-9	-1	-10	-11	-9	+1	+14	+24	+27	+22	+15	+7	+1	-2	-4	-5	-4	-4	-4	-4	-7	-7
	1891	-7	-4	-8	-1	-14	-13	-7	+2	+18	+27	+27	+23	+11	+4	-2	-1	0	-3	-5	-5	-5	-5	-6	-8
	Mean.	-6	-5	-7	-9	-10	-10	-6	+2	+14	+21	+22	+19	+10	+4	-1	-2	-1	-3	-3	-3	-3	-4	-5	-6
Nov..	1889	-3	-4	-3	-5	-7	-7	-8	-5	+2	+9	+11	+12	+8	+1	0	-2	-2	-1	+2	+3	+1	0	-1	-3
	1890	+3	0	-3	-4	-5	-8	+2	-3	+4	+7	+9	+8	+4	0	-2	-3	-3	0	0	+1	+2	-1	+2	+3
	1891	-2	-3	-3	-5	-9	-12	-11	-4	+7	+16	+19	+22	+19	+12	+3	-3	-6	-6	-6	-3	-3	-5	-2	-3
	Mean.	-1	-2	-3	-5	-7	-9	-6	-4	+4	+11	+13	+14	+10	+4	0	-3	-4	-2	-1	0	0	-2	0	-1
Dec..	1889	0	0	-1	-3	-4	-5	-7	-6	-4	+3	+11	+13	+10	+5	0	-3	-4	-2	-1	0	0	0	+1	+1
	1890	+2	-1	-3	-5	-9	-9	-8	-9	-7	0	+11	+15	+14	+10	+4	-1	-3	-2	-1	+1	+2	+3	+4	+3
	1891	-1	-2	-3	-5	-8	-10	-10	-8	-2	+7	+20	+23	+17	+9	0	-6	-6	-6	-4	-4	-1	0	0	0
	Mean.	0	-1	-2	-4	-7	-8	-8	-8	-4	+3	+14	+17	+14	+8	+1	-3	-4	-3	-2	-1	0	+1	+2	+1

TABLE XII.

Diurnal variation of the vertical intensity of the earth's magnetic force as derived from the continuous observations at the Washington Magnetic Observatory from 1889-91.

The quantities are expressed in units of the fifth decimal C. G. S. system, and are given for hours of 75 Meridian Time which is 8 m. 12 s. fast on local mean time. Plus sign indicates less, and minus sign greater than mean of day.

Month.	Year.	HOURS.																								
		A. M.												P. M.												
		1	2	3	4	5	6	7	8	9	10	11	12	1	2	3	4	5	6	7	8	9	10	11	12	
Jan.	1889 <sup>1</sup>	-2	-1	-1	-1	-1	-1	-1	-1	-1	+2	+2	+6	+7	+1	0	0	-1	-1	-1	-1	-1	-1	0	0	
	1891 <sup>2</sup>	+2	+2	+2	+2	+2	+3	+1	-1	-1	+3	+6	+6	+1	-2	-5	-5	-3	-4	-4	-3	-2	-1	0	+1	
	1892	-2	-2	-1	+1	+2	+3	+1	0	+3	+7	+7	+4	+3	+3	+1	+1	-1	-1	-3	-6	-8	-8	-4	-1	-1
	Mean.	-1	0	0	+1	+1	+2	0	-1	+1	+4	+6	+6	+2	0	-1	-2	-2	-3	-4	-4	-4	-2	0	0	
Feb.	1889	-1	-1	-1	-2	-2	-3	-3	-2	0	+2	+5	+9	+2	0	-2	-2	-1	+1	+1	-1	-1	-1	0	+1	
	1890	-3	-1	-1	-1	-2	-2	-2	-2	-1	+1	+3	+4	+4	+3	+2	+2	+2	+2	+1	0	-2	-3	-3	-2	
	1891	-2	-1	0	+1	+1	+2	0	+1	+3	+6	+8	+6	+4	+1	-2	-3	-5	-6	-6	-6	-4	-4	-2	-1	
	Mean.	-2	-1	-1	-1	-1	-1	-2	-1	+1	+5	+5	+6	+3	+1	-1	-1	-1	-1	-1	-2	-2	-3	-2	-1	
Mar.	1889	+1	+1	+2	-2	0	-1	-1	-1	0	+3	+7	+7	+4	+3	+1	0	-2	-3	-3	-4	-4	-4	-3	-2	
	1890	-1	-1	-1	-1	0	-1	-1	-1	0	+2	+4	+4	+3	+3	+1	+1	0	0	0	-1	-2	-3	-2	-1	
	1891	+2	+3	+4	+4	+4	+4	+2	+3	+5	+9	+14	+13	+8	+4	-1	-5	-7	-12	-11	-11	-11	-9	-7	-4	
	Mean.	+1	+1	+2	0	+1	+1	0	0	+2	+5	+8	+8	+5	+3	0	-1	-3	-5	-5	-5	-6	-5	-4	-2	
Apr.	1889	+2	0	-1	-1	-1	-3	-2	-2	0	+1	+8	+7	+5	+1	+1	-2	-3	-3	-2	-2	-2	-1	-1	0	
	1890	-1	0	0	0	-1	-1	-1	-1	+1	+5	+7	+7	+4	+1	-2	-4	-4	-3	-1	-1	-2	-2	-2	-1	
	1891	+3	+4	+4	+12	+8	+8	+4	+1	+2	+7	+12	+12	+11	+4	-2	-10	-15	-17	-17	-11	-10	-7	-2	+2	
	Mean.	+1	+1	+1	+4	+2	+1	0	-1	+1	+4	+9	+9	+7	+2	-1	-5	-7	-8	-7	-5	-5	-3	-2	0	
May.	1889	+1	+2	+1	0	-1	-2	-3	-2	0	+5	+8	+7	+5	+1	-3	-4	-5	-4	-2	-2	-2	-1	0	+2	
	1890	-1	0	-1	-2	-3	-3	-3	-2	0	+4	+7	+7	+6	+4	-2	-4	-4	-3	-1	0	0	0	0	+1	
	1891	-3	-5	-4	-1	+3	+3	+4	+6	+9	+11	+11	+7	+6	-3	-4	-5	-8	-7	-8	-7	-5	-2	+1	+2	
	Mean.	-1	-1	-1	-1	0	-1	-1	+1	+3	+7	+9	+7	+6	+1	-3	-4	-6	-5	-4	-3	-2	-1	0	+2	
June.	1889	-1	0	0	0	-1	-2	-2	-2	0	+4	+6	+6	+5	+3	+1	-4	-4	-4	-2	-1	-1	-1	0	0	
	1890	-1	-1	0	-1	-4	-4	-3	-2	0	+4	+7	+9	+9	+6	+1	-3	-5	-5	-3	-2	-2	-2	-1	-1	
	1891	-1	+1	0	-1	-5	-6	-6	-4	+1	+8	+12	+14	+15	+12	+9	-1	-3	-8	-8	-7	-7	-6	-5	-4	
	Mean.	-1	0	0	-1	-3	-4	-4	-3	0	+5	+8	+10	+10	+7	+4	-3	-4	-6	-4	-3	-3	-3	-2	-2	

<sup>1</sup> Mean of 6 days only.

<sup>2</sup> January 1890 lacking.

TABLE XII.—Concluded

*Diurnal variation of the vertical intensity of the earth's magnetic force as derived from the continuous observations at the Washington Magnetic Observatory from 1889-91.*

The quantities are expressed in units of the fifth decimal C. G. S. system, and are given for hours of 75 Meridian time which is 8m. 12s. fast on local mean time. Plus sign indicates less, and minus sign greater than mean of day.

Month.	Year.	HOURS.																							
		A. M.												P. M.											
		1	2	3	4	5	6	7	8	9	10	11	12	1	2	3	4	5	6	7	8	9	10	11	12
July.	1889	+1	+2	+4	+3	-1	-2	-2	-1	+1	+4	+6	+6	+5	+2	-1	-3	-6	-6	-5	-4	-2	-1	0	+1
	1890	+1	+2	+1	-1	-5	-7	-7	-5	0	+7	+13	+14	+15	+10	+2	-4	-9	-8	-7	-5	-5	-4	-4	-3
	1891	-1	0	+1	0	-2	-2	-2	-1	+1	+2	+9	+10	+12	+8	+1	-3	-7	-7	-6	-5	-4	-2	-1	-1
	Mean.	0	+1	+2	+1	-3	-4	-4	-2	+1	+4	+9	+10	+11	+7	+1	-3	-7	-7	-6	-5	-4	-2	-2	-1
Aug.	1889	+6	+5	+3	+4	-4	-8	-8	-4	0	+4	+9	+11	+16	+7	0	-8	-10	-8	-3	-2	-2	-1	0	0
	1890	+1	+1	+1	+1	0	-3	-2	0	+4	+8	+8	+7	+6	+2	-2	-5	-6	-5	-3	-3	-3	-3	-2	-1
	1891	+1	0	0	0	-1	-2	-3	-1	+3	+9	+12	+11	+9	+4	-2	-5	-9	-8	-6	-4	-4	-2	-2	+1
	Mean.	+3	+2	+1	+2	-2	-4	-4	-2	+2	+7	+10	+10	+10	+4	-1	-6	-8	-7	-4	-3	-3	-2	-1	0
Sept.	1889	+6	+8	+7	+7	+7	+4	+4	+4	+4	+7	+12	+15	-3	-6	-10	-13	-12	-12	-10	-8	-5	-5	-3	+3
	1890	0	+4	+4	+4	+4	+2	+2	+2	+4	+5	+8	+6	+6	-1	-5	-7	-8	-6	-7	-7	-5	-3	-2	-1
	1891	+3	+2	+4	+4	+4	+4	+4	+6	+6	+7	+7	+6	+1	-2	-5	-10	-12	-10	-8	-7	-4	-3	0	+2
	Mean.	+3	+5	+5	+5	+5	+3	+3	+4	+5	+6	+9	+9	+1	-3	-7	-10	-11	-9	-8	-7	-5	-4	-2	+1
Oct.	1889	+1	+2	+3	+2	+1	0	-1	-1	0	+3	+8	+8	+1	-1	-2	-5	-4	-4	-4	-5	-3	-1	0	+1
	1890	0	+2	+2	+1	+1	+1	-2	-3	-2	+1	+5	+5	+8	+6	+1	0	-3	-3	-4	-4	-4	-3	-2	-1
	1891	+5	+5	+3	+3	+3	+2	0	0	0	+2	+5	+5	+5	+2	-1	-3	-6	-6	-7	-6	-5	-4	-2	0
	Mean.	+2	+3	+3	+2	+2	+1	-1	-1	-1	+2	+6	+6	+5	+2	-1	-3	-4	-4	-5	-5	-4	-3	-1	0
Nov.	1889	+4	+6	+8	+7	+6	+5	+6	+7	+10	+14	+18	+11	-8	-8	-10	-7	-6	-9	-11	-13	-11	-10	-7	-3
	1890	+1	+2	+1	0	-1	-2	-2	-1	0	+1	+2	+2	+4	0	0	0	-1	-1	-2	-2	-1	-1	0	0
	1891	+1	+2	+2	+2	+2	+2	0	0	+2	+5	+7	+8	+3	-1	-4	-5	-4	-5	-5	-4	-4	-3	-2	0
	Mean.	+2	+3	+4	+3	+2	+2	+1	+2	+4	+7	+9	+7	0	-3	-5	-4	-4	-5	-6	-6	-5	-5	-3	-1
Dec.	1889	-2	0	-1	0	-2	-1	0	0	+4	+13	+15	+12	-7	-5	-2	-2	+1	0	-2	-3	-5	-6	-5	-2
	1890	0	0	0	-1	-1	-1	-2	-2	-1	0	0	0	+3	+1	0	+1	+1	+1	0	0	0	0	0	0
	1891	0	0	0	0	+1	+1	0	0	+1	+3	+6	+5	+2	0	-2	-1	-1	-3	-3	-3	-2	-2	-1	0
	Mean.	-1	0	0	0	-1	-1	-1	-1	+1	+5	+7	+6	-1	-1	-1	-1	-1	0	-1	-2	-2	-2	-3	-2

TABLE XIII.

*Diurnal variation of the magnetic dip as derived from the 3 years 1889-91 continuous observations at the Washington Magnetic Observatory.*

The hours given are for the 75 Meridian Mean Time which is 8m. 12s. fast on local mean time. Plus sign of tabular quantities means less, and minus sign greater than mean of day, hence the table gives the corrections to be applied to an observed quantity to obtain the mean value of the day.

Month.	1	2	3	4	5	6	7	8	9	10	11	M	1	2	3	4	5	6	7	8	9	10	11	M
Jan...	+0	+1	+2	+3	+3	+4	+4	+4	+3	-.3	-.3	-.9	-1.1	-.8	-.4	-.1	+2	+2	+3	+1	+0	-0	+0	+0
Feb...	-1	+0	+1	+1	+2	+2	+3	+2	+2	.0	.3	.4	-.5	-.3	-.2	-0	+1	+1	+0	-0	-1	-0	-0	-0
Mar...	+2	+2	+2	+3	+4	+3	+3	+0	-.2	-.6	-.4	-.4	-.3	-1	+1	+1	+1	-1	-1	-1	-1	+0	+0	+1
April...	+2	+2	+2	+3	+4	+3	+1	-.3	-.7	-1.0	-.8	-.3	-1	+2	+4	+3	+2	+1	-1	+1	+1	+1	+1	+2
May...	-0	+0	+1	+1	+1	+2	-1	-.5	-1.0	-1.0	-.6	-0	+5	+7	+6	+4	+2	+0	-0	-0	-0	-0	+0	+1
June...	+0	+0	+0	+0	+1	+1	-0	-.4	-.7	-.9	-.6	-1	+3	+6	+6	+5	+2	+0	-0	+0	+1	.0	+1	-0
July...	+2	+1	+2	+0	+1	+1	-0	-.4	-.8	-1.0	-.8	-.3	+2	+5	+6	+5	+2	+0	-0	-0	-0	+1	+0	+1
Aug...	+4	+3	+2	+2	+2	+2	+0	-0	-1.1	-1.1	-.9	-.4	+2	+4	+5	+3	+1	+1	+0	+2	+2	+2	+1	+2
Sept...	+3	+4	+4	+4	+5	+4	+3	-3	-.8	-1.1	-1.0	-6	-.3	.0	+2	+2	+1	.0	+0	+0	+1	+1	+2	+3
Oct...	+4	+2	+4	+5	+6	+6	+3	-1	-.8	-1.1	-1.1	-9	-.4	-2	+0	+1	-0	+1	+1	+1	+1	+1	+2	+3
Nov...	+1	+2	+2	+3	+4	+5	+3	+2	-1	-.4	-.5	-6	-.5	-.3	-1	+1	+1	+0	-1	-1	-1	+0	+0	+0
Dec...	-0	+0	+1	+2	+3	+4	+4	+4	+2	-1	-.6	-.8	-.8	-.4	-1	+1	+2	+1	+1	+0	-0	-1	-2	-1
Mean.	+1	+2	+2	+2	+3	+3	+2	-1	-.5	-.6	-.7	-.5	-.2	+1	+2	+2	+2	+1	.0	.0	+0	+0	+1	+1

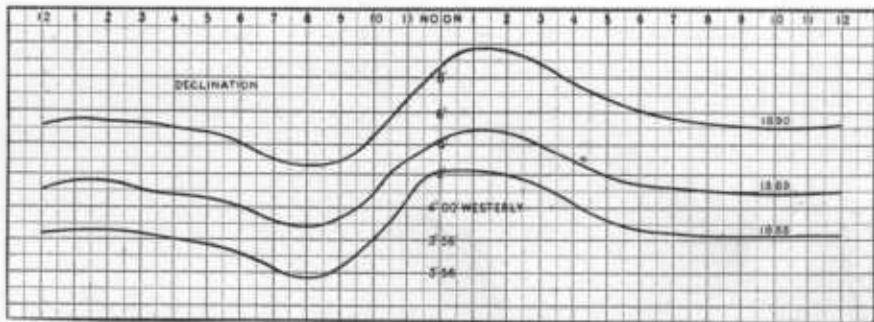

FIG. 1. Diurnal variation of the magnetic declination at Washington, D. C. (1888-90).

Figure 1 gives a diagrammatic representation of the diurnal variation of the declination, Figure 2, that of the inclination, and Figure 3, the diurnal variation of the two elements combined.<sup>1</sup> This diagram (Figure 3) represents the path described in the course of a

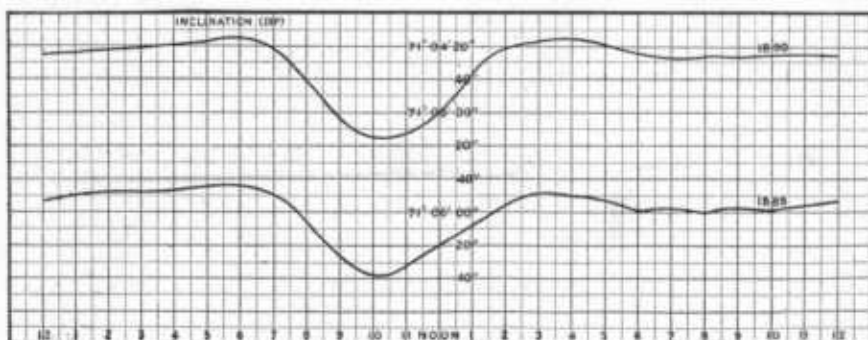

FIG. 2. Diurnal variation of the magnetic inclination at Washington, D. C. (1889-1890).

day by the north end of a freely-suspended magnetic needle, as viewed from the center of suspension, supposing that the earth's permanent magnetic field were eliminated and that the needle were acted upon alone by the magnetic field producing the diurnal vari-

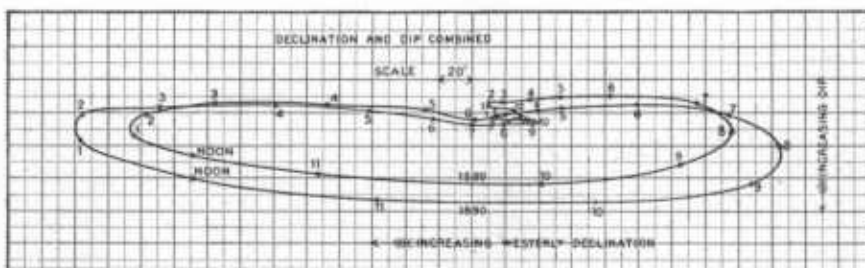

FIG. 3. Diurnal variation of curve of declination and inclination at Washington, D. C. (1889-1890).

ation of the earth's magnetism (compare the similar diagrams for the secular variation on p. 472 of the First Report). For the diurnal variation, the changes in declination and inclination are only

<sup>1</sup>The three figures are taken from the publications of the Washington Magnetic Observatory for 1887, Appendix 2.

a few minutes of arc, for the secular variation, they are on the other hand a matter of several degrees and the curves cannot yet be closed nor is it at all likely that they ever will be strictly closed. So, likewise, the diurnal variation curves according to recent investigations, do not appear to be strictly closed curves. It is possible that the slight magnetic effect recently observed in the United States during the time of the total eclipse of the sun on May 28, 1900, may throw some light on the peculiar retrograde movement of the diurnal variation needle during the night hours. See Figure 3.

#### ACCURACY OF THE OBSERVATIONS.

The corrections to an observed inclination observation, as given in Table XIII, do not strictly apply to the period of the observations of the magnetic survey because of the manifold other variations continually taking place. Fortunately, in the case of this element, these variations, as well as the diurnal variation—the maximum correction on account of which is but 1'—are small in comparison with those of the diurnal variation of the declination, though their absolute effect, had we as accurate means for measuring the dip as the declination would be equally as great. As long, however, as we must be content to measure a dip within 1' or 2' with our present dip-circles, the reduction errors on account of the disturbance variation and the annual variation (not to be confounded with annual or secular change) are in general negligible quantities. A discussion of the many repeat observations at the base station, Linden, showed that the probable error of an observation was reduced by applying the corrections given in Table XIII.

An idea of the combined effect on a single observed result of the dip produced by the observing error and by the total reduction error (diurnal variation, disturbance variation, annual and secular variation) will be obtained by glancing over the residuals in the last column of Table XIV, which gives in detail the results of the repeat observations at Linden. These residuals representing the differences of the separate results from the mean of all (21) amount in one case to nearly 4', in general, however, they are considerably

less. The *mean square error of a single result* (the mean of two independent observations, I and II, with needle No. 1) is:

$$\mu = \sqrt{\frac{[vv]}{n-1}} = \pm 2'.03$$

and the *probable error of a single result* is:

$$\varepsilon = \pm 0.6745 \sqrt{\frac{[vv]}{n-1}} = \pm 1'.37$$

These figures, as stated, represent the total error—observing and reduction error. We can get some idea of the observing error from a consideration of the differences, I-II, given in Tables XIV and XV. From these we find as the *mean square observing error* of the mean of I and II:

$$\mu' = \sqrt{\frac{[dd]}{4n}} = \pm 1'.17$$

and for the *probable observing error*:

$$\varepsilon' = 0.6745 \sqrt{\frac{[dd]}{4n}} = \pm 0'.79$$

These quantities are smaller than the preceding ones, as was to be expected, since the error of reduction to mean of day, January 1, 1900, is not included and, furthermore, because they are derived from the results obtained *under the same conditions* and not under the varying conditions of an entirely independent remounting of the instrument at a different time, so that  $\mu'$  and  $\varepsilon'$  would need to be somewhat increased in order that they might represent the actual observing error.

While these figures show that all needful accuracy, for the present purpose of the magnetic survey, had been obtained, they do not represent the highest degree of accuracy attainable with the very best dip instruments. Since these observations have been made, the writer upon taking charge of the magnetic survey of the United States, has had all of the dip instruments of the Coast and Geodetic Survey examined and intercompared, so that they may be referred to one particular dip-circle (No. 23) provisionally selected as the standard instrument. This particular dip-circle has, furthermore, been compared at Washington with two earth inductors of different



construction and has been found to agree with each within a few tenths of a minute. Needle No. 1 of the dip-circle (56/4440) used in the magnetic survey of Maryland had a correction in 1900 on No. 23 of about  $-1'$ . As the correction to a needle is generally traceable to imperfections in the figure of its pivots and is, therefore, subject to a possible variation with constant use of the needle, *it has not been deemed safe to apply any correction to the dip results during the magnetic survey to refer them to the Coast and Geodetic Survey Standard Dip Instrument.* Fortunately all evidence goes to show that if there be a correction, it will not be much over  $1'$ .

## TABLES.

The headings of the columns of the various tables do not require any further explanation. The local mean time of an observation is given counting from midnight to midnight, from 0 to 24 hours. Tables XIII, XIV and XV give the observations in sufficient detail. The summary of the results is found in a subsequent chapter.

TABLE XIV.

*Magnetic inclinations observed at Base Station, Linden, Montgomery County, between the years 1896 and 1900.*

[All observations by L. A. Bauer, except Nos. 16, 17 and 18, which were made by J. A. Fleming.]

No. of Observation.	Date.		Local mean time of observation.		Observed Inclinations.		Diff. I-II.	Mean Inclination.	Reduction to Jan. 1, 1900.	Inclination at Jan. 1, 1900.	Diff. from mean.
	Month and Day.	Year and decimal.	I.	II.	I.	II.					
1	July 13-Aug. 7.	1896 .56	various	various	.....	.....	.....	70 46 61	-5.270	41.4	+0.5
2	Sept. 4.....	1896 .67	8 47	9 47	70 46.370	48.4	-2.1	47.4	-5.0	42.4	-0.5
3	" 14.....	1896 .70	16 25	17 45	48.4	45.2	+3.2	46.8	-5.0	41.8	+0.1
4	" 14.....	1896 .70	18 41	19 19	50.0	48.7	+1.3	49.4	-5.0	44.4	-2.5
5	Oct. 28.....	1896 .82	15 04	16 44	47.6	47.4	+0.2	47.5	-4.8	42.7	-0.8
6	Nov. 24.....	1896 .90	16 04	16 16	43.6	43.0	+0.6	43.3	-4.6	38.7	+3.2
7	" 27.....	1896 .91	12 57	15 58	43.4	44.2	-0.8	43.8	-4.6	39.2	+2.7
8	Apr. 14.....	1897 .29	14 42	15 02	46.1	46.6	-0.5	46.3	-4.1	42.2	-0.3
9	June 21.....	1897 .47	10 26	16 37	43.5	42.2	+1.3	42.8	-3.8	39.0	+2.9
10	July 25.....	1897 .56	19 30	19 48	48.2	47.2	+1.0	47.7	-3.7	44.0	-2.1
11	Sept. 18.....	1898 .72	11 27	11 47	45.3	48.2	-2.9	46.7	-1.9	44.8	-2.9
12	" 24.....	1898 .73	13 29	13 51	45.8	46.6	-0.8	46.2	-1.9	44.3	-2.4
13	May 10.....	1899 .36	15 43	16 42	41.9	44.4	-2.5	43.2	-1.0	42.2	-0.3
14	" 12.....	1899 .36	15 53	16 30	42.6	41.4	+1.2	42.0	-1.0	41.0	+0.9
15	" 15.....	1899 .37	9 33	10 03	41.8	43.4	-1.6	42.6	-0.9	41.7	+0.2
16	July 6.....	1899 .51	12 56	11 45	46.5	46.2	+0.3	46.4	-0.7	45.7	-3.8
17	" 7.....	1899 .52	12 52	11 06	41.8	46.0	-4.2	43.9	-0.7	43.2	-1.3
18	" 8.....	1899 .52	11 28	10 31	41.4	44.0	-2.6	42.7	-0.7	42.0	-0.1
19	" 18.....	1900 .54	19 09	19 09	37.5	39.0	-1.5	38.2	+0.8	39.0	+2.9
20	" 19.....	1900 .54	19 00	19 00	38.3	40.2	-1.9	39.2	+0.8	40.0	+1.9
21	" 20.....	1900 .55	11 35	11 35	41.2	38.8	+2.4	40.0	+0.8	40.8	+1.1
Mean.....									70	41.93	

<sup>1</sup> Mean of 6 practice sets made in vicinity of station before magnetic survey was started.

TABLE XV

Magnetic inclinations observed at various stations in Maryland between the years 1896 and 1899.

[All observations by L. A. Bauer.]

No.	Station.	Date.		Local mean time of observation.		Observed Inclination.		Diff. I-II.	Mean Inclination.	Reduction to Jan. 1, 1900.	Inclination at Jan. 1, 1900.
		Month and day.	Year and decimal 1890 +	I.	II.	I.	II.				
2	Upper Marlboro	Sept. 9	6.69	14:29	15:06	70 20.2	70 24.2	-4.0	70 22.2	-5.070	17.2
3	La Plata	" 10	6.69	13:23	15:01	70 05.1	70 00.9	+4.2	70 03.0	-5.069	58.0
	"	June 4	7.42	10:41	10:59	70 00.9	70 02.6	-1.7	70 01.8	-3.969	57.9
									Mean	..	69 58.0
4	Brandywine	Sept. 10	6.69	16:14	16:44	70 14.6	70 15.7	-1.1	70 15.2	-5.070	10.2
5	Mechanicsville	" 11	6.70	8:55	10:15	69 48.2	69 46.8	+1.4	69 47.5	-5.069	42.5
6	Leonardtown	" 11	6.70	18:07	18:53	69 37.1	69 36.7	+0.4	69 36.9	-5.069	31.9
7	Easton, Hotel	" 16	6.71	11:01	18:06	70 10.9	70 16.5	-5.6	70 13.7*	-4.970	08.8*
7A	" F. G.	June 24	6.78	16:19	16:37	70 14.0	70 17.6	-3.6	70 15.8	-3.870	12.0
8	Centreville, S. H.	Sept. 17	6.71	12:33	17:40	70 33.0	70 30.8	+2.2	70 31.9	-4.970	27.0
	"	May 27	7.40	17:06	17:26	70 32.2	70 32.2	0.0	70 32.2	-3.970	28.3
									Mean	..	70 27.6
9	Massey	Sept. 18	6.72	12:52	13:15	70 52.9	70 52.0	+0.9	70 52.4	-4.970	47.5
10	Ridgely	" 19	6.72	6:53	7:06	70 26.4	70 29.2	-2.8	70 27.8	-4.970	22.9
11	Hurlock	" 19	6.72	18:03	18:23	70 06.8	70 08.3	-1.5	70 07.6	-4.970	02.7
12	Ocean City	" 21	6.72	12:49	13:06	70 02.9	70 00.8	+2.1	70 01.8	-4.969	56.9
13	Berlin	" 23	6.73	7:45	8:07	69 58.4	69 58.5	-0.1	69 58.4	-4.969	53.5
14	Snow Hill	" 23	6.73	17:42	18:00	69 42.2	69 41.4	+0.8	69 41.8	-4.969	36.9
15	Pocomoke City	" 24	6.73	11:32	11:48	69 43.0	69 44.7	-1.7	69 45.8	-4.969	38.9
16	Princess Anne	" 24	6.73	14:31	14:49	69 55.7	69 50.0	+5.7	69 52.8	-4.969	47.9
17	Salisbury, C. H.	" 25	6.73	8:11	8:29	69 59.1	69 55.8	+3.3	69 57.4*	-4.969	52.5*
17A	" M. L.	Dec. 4	6.93	11:25	3:50	70 04.4	70 02.7	+1.7	70 03.5	-4.669	58.9
18	Parsonsburg	Sept. 25	6.73	13:38	13:53	70 02.0	70 03.9	-1.9	70 03.0	-4.969	58.1
19	Cockeysville	" 26	6.74	13:03	13:25	71 00.4	71 00.1	+0.3	71 00.2	-4.970	55.3
20	Frederick, Asyl.	Oct. 5	6.76	14:19	14:49	70 46.8	70 47.4	-0.6	70 47.1	-4.970	42.2
20A	" C. H.	" 7	6.77	16:57	17:17	70 38.9	70 38.6	+0.3	70 38.7*	-4.870	33.9*
21	Westminster	" 8	6.77	13:22	13:39	70 32.5	70 35.7	-3.2	70 34.1	-4.870	29.3
22	Hagerstown	" 9	6.77	17:07	17:25	71 04.7	71 03.7	-1.0	71 04.2	-4.870	59.4
23	Cumberland	" 10	6.77	14:06	14:22	70 57.4	71 01.3	-3.9	70 59.4	-4.870	54.6
24	Oakland, S. H.	" 12	6.78	11:50	12:06	70 42.1	70 42.5	-0.4	70 42.3 <sup>1</sup>	-4.870	37.5 <sup>1</sup>
24A	" C. H.	Aug. 2	7.58	11:24	11:44	70 42.2	70 38.3	+3.9	70 40.2	-3.670	36.6
	"	June 5	9.43	10:51	11:09	70 37.1	70 32.0	+5.1	70 34.6	-0.970	33.7
									Mean	..	70 35.2
25	Point of Rocks	Oct. 13	6.78	10:14	10:39	70 48.1	70 46.4	+1.7	70 47.2	-4.870	42.4
26	Dickerson	" 13	6.78	16:20	16:36	70 59.7	70 59.0	+0.7	70 59.4	-4.870	54.6
27	Elkton	" 15	6.79	11:08	11:08	70 58.6	70 56.3	+2.3	70 57.4	-4.870	52.6
28	Prince Frederick	" 19	6.80	9:25	9:53	69 58.7	69 56.3	+2.4	69 57.5	-4.869	52.7
29	Belair Hotel	" 20	6.80	15:06	15:22	70 26.1	70 26.5	-0.4	70 26.3	-4.870	21.5
	"	Nov. 7	6.85	8:00	8:20	70 20.2	70 27.1	-6.9	70 23.6	-4.770	18.9
									Mean	..	70 20.2
29A	Belair, Dallam	May 4 & 15	7.35	18:10	12:50	70 13.2	70 15.9	-2.7	70 14.6	-4.070	10.6
29B	" Davidson	" 15	7.37	12:07	...	70 23.3	...	...	70 23.3	-3.970	19.4
29C	" C. H.	" 4	7.34	17:17	17:33	70 09.4	70 13.3	-3.9	70 11.4*	-4.070	07.4*
											70 38.8
30	Annapolis	Oct. 21	6.80	...	11:38	70 40.8	70 39.6	-0.8	70 39.7	-4.870	34.9
31	Ellicott	" 22	6.81	17:10	17:26	70 39.9	70 36.5	+3.4	70 38.2	-4.870	33.4
32	Baltimore, Fort.	Nov. 5	6.85	15:12	15:30	70 59.3	71 00.2	-0.9	70 59.8	-4.770	55.1
32A	" Meeter's	" 5	6.85	17:04	17:21	70 54.9	70 55.8	-0.9	70 55.3	-4.770	50.6
32B	" St. Mary	July 14	7.53	15:03	...	70 36.8	...	...	70 36.8*	-3.770	33.1*
33	Belcamp	Nov. 6	6.85	11:13	11:30	71 06.5	71 06.8	-0.3	71 06.6	-4.771	01.9
34	Harford Furnace	" 6	6.85	15:11	15:23	71 04.5	71 03.6	+0.9	71 04.0	-4.770	59.3
35	Creswell	" 6	6.85	16:20	...	71 07.6	...	...	71 07.6	-4.771	02.9
36	Fountain Green	" 6	6.85	17:08	...	70 48.3	...	...	70 48.3	-4.770	43.6
37	Cardiff, R. R.	" 7	6.85	11:55	...	71 16.2	...	...	71 16.2	-4.771	11.5
37A	" Ball F.	May 10	7.36	9:26	9:38	70 30.6	70 32.5	-1.9	70 31.6	-4.070	27.6
37B	" Bd. St.	" 10	7.36	12:07	12:53	72 23.3	70 26.5	-3.2	70 24.9	-4.070	20.9

<sup>1</sup> Severe magnetic storm.

\* Observations marked with an asterisk are affected by artificial local attraction and should not be used.

TABLE XV.—Continued.

Magnetic inclinations observed at various stations in Maryland between 1896 and 1899.

No.	Station.	Date.		Local mean time of observation.		Observed Inclination.		Diff.	Mean Inclination.	Reduction to Jan. 1, 1900.	Inclination at Jan. 1, 1900
		Month and day.	Year and decimal 1890 +	I.	II.	I.	II.				
37C	Cardiff Ramsay's	May 10	7.36	h. m.	h. m.	71 05.2			71 05.2	-4.0	71 01.2
37D	" Serp. Qu.	" 10	7.36	16:47		73 19.8			73 19.8	-4.0	73 15.8
37E	" Slate Qu.	" 10	7.36	17:39	17:56	70 41.6	70 42.1	-0.5	70 41.8	-4.0	70 37.8
37F	" ¼ mile W.	" 11	7.36	18:02		71 57.3			71 57.3	-4.0	71 53.3
37G	" Whiteford Qu.	" 12	7.36	11:04		73 12.0			73 12.0	-4.0	73 08.0
37H	" Flaherty's	" 12	7.36	11:45		71 18.9			71 18.9	-4.0	71 14.9
37I	" Cambria	" 12	7.36	12:41		70 54.8			70 54.8	-4.0	70 50.8
37J	" Sch. H.	" 13	7.36	7:09	7:25	70 35.1	70 38.2	-3.1	70 37.7	-4.0	70 33.7
37K	" Peerless Qu.	" 14	7.37	12:03		70 49.8			70 49.8	-3.9	70 45.9
38	Forest Hill	Nov. 7	6.85	13:53	14:12	71 05.5	71 07.7	-2.2	71 06.6	-4.7	71 01.9
39	Stabler	" 13	6.87	15:29	15:45	70 27.4	70 31.1	-3.7	70 29.2	-4.7	70 24.5
40	Unity	" 14	6.87	7:44	8:29	70 27.1	70 28.1	-1.0	70 27.6	-4.7	70 22.9
41	Damascus	" 14	6.87	14:45	15:03	70 50.2	70 50.6	-0.4	70 50.4	-4.7	70 45.7
1A	Linden, A. S.	" 25	6.90	16:42	16:54	70 30.5	70 31.3	-0.8	70 30.9	-4.6	70 26.3
42	Forest Glen	July 20	6.55	16:20	17:00	70 29.4	70 30.5	-1.1	70 29.9	-5.2	70 24.7
	" "	Nov. 25	6.90	12:03	12:19	70 29.0	70 28.1	+0.9	70 28.6	-4.6	70 24.0
									Mean . . .		70 24.4
43	Crisfield	Dec. 7	6.93	15:23	15:39	69 36.6	69 37.0	-0.4	69 36.8	-4.6	69 32.2
44	Cambridge	Apr. 17	7.29	18:08	18:24	69 59.5	69 59.5	0.0	69 59.5	-4.1	69 55.4
45	Tilghman Is.	" 19	7.30	15:37	15:53	70 04.8	70 08.9	+0.9	70 04.4	-4.0	70 00.4
47	Towson, N. M.	May 7	7.35	15:17	13:57	70 54.4	70 55.0	-0.6	70 54.7	-4.0	70 50.7
47A	" S. M.	" 7	7.35	13:35	13:57	70 57.5	70 56.6	+0.9	70 57.1	-4.0	70 53.1
									Mean . . .		70 51.9
48	Hyde's	May 7	7.35	17:53		70 49.0			70 49.0	-4.0	70 45.0
49	Churchville	" 8	7.35	11:58		70 55.8			70 55.8	-4.0	70 51.8
50	Thomas Run	" 8	7.35	15:10		70 43.3			70 43.3	-4.0	70 39.3
51	Hickory	" 8	7.35	16:40		71 26.8			71 26.8	-4.0	71 22.8
52	Highland	" 14	7.37	15:06		71 03.4			71 03.7	-3.9	70 59.8
53	Minefield	" 14	7.37	16:14		72 04.8			72 04.8	-3.9	72 00.9
54	Dublin	" 15	7.37	6:18		72 15.0			72 15.2 <sup>1</sup>	-3.9	72 11.3 <sup>1</sup>
55	Scarboro	" 15	7.37	8:35	9:29	70 37.8	70 40.6	-2.8	70 39.2	-3.9	70 35.3
56	Bradshaw	" 20	7.38	17:02		71 17.0			71 17.0	-3.9	71 13.1
57	Chestertown, C. H.	" 29	7.41	15:06	15:28	70 30.7	70 31.3	-0.6	70 31.0*	-3.9	70 27.1*
57A	" Wash. C.	" 31	7.41	17:47	18:03	70 40.7	70 41.4	-0.7	70 41.0	-3.9	70 37.1
58	Tolchester	June 1	7.42	17:36	17:48	70 49.3	70 53.4	-4.1	70 51.4	-3.9	70 47.5
59	Oxford	" 25	7.48	13:28	14:03	70 05.0	70 06.6	-1.6	70 05.8	-3.8	70 02.0
60	Fair Haven	" 26	7.49	13:45	14:10	70 13.6	70 11.2	+2.4	70 12.4	-3.8	70 08.6
61	Laurel	July 1	7.50	13:59	14:11	70 45.7	70 43.8	+1.9	70 44.8	-3.8	70 41.0
62	Rockville	" 9	7.52	7:48	8:04	70 05.5	70 06.2	-0.7	70 05.9	-3.7	70 02.2
63	Webb	" 16	7.54	15:34	16:19	70 41.5	70 44.4	-2.9	70 43.0	-3.7	70 39.3
64	Kent I., S. B	" 19	7.55	13:29	13:30	70 31.8	70 31.8	0.0	70 31.8	-3.7	70 28.1
65	Kent I., Stevensville	" 20	7.55	7:41		70 31.6			70 31.6	-3.7	70 27.9
66	Bay Ridge	" 22	7.56	18:09	18:28	70 34.4	70 33.9	+0.5	70 34.2	-3.7	70 30.5
67	Seneca	" 26	7.57	14:00	14:17	70 56.6	70 54.0	+2.6	70 55.3	-3.6	70 51.7
68	Maryland Hts.	" 27	7.57	13:34	14:04	70 55.2	70 50.2	+5.0	70 52.7	-3.6	70 49.1
68A	" H. Farm.	" 28	7.57	7:57	8:37	70 48.6	70 47.3	+1.3	70 48.0	-3.6	70 44.4
69	Hancock	" 28	7.57	17:08	17:37	71 03.1	71 01.6	+1.5	71 02.3	-3.6	70 58.7
70	Corunna	" 31	7.58	17:40	17:55	70 36.0	70 42.7	-6.7	70 39.4	-3.6	70 35.8
71	Westernport	Aug. 3	7.59	13:21	13:43	70 51.4	70 50.6	+0.8	70 51.0	-3.6	70 47.4
72A	Fairfax St.	" 5 & 6	7.59	16:14	15:17	70 27.7	70 29.9	-2.2	70 28.8	-3.6	70 25.2
73	Fairfax Camp	" 7	7.60	16:15	16:47	70 35.1	70 33.7	+1.4	70 34.4	-3.6	70 30.8
74	Backbone Mtn.	" 30 & 31	7.66	18:12	17:07	70 30.1	70 28.3	+1.8	70 29.2	-3.5	70 25.7
	" "	" 31 & Sept. 1	7.67	18:24	18:27	70 28.3	70 28.1	+0.2	70 28.2	-3.5	70 24.7
									Mean . . .		70 25.2
75	Camp Potomac	Sept. 17	7.68	19:15	18:08	70 33.3	70 29.8	+3.5	70 31.6	-3.5	70 28.1
76	Foley Mtn.	" 21	7.72	9:27	9:47	70 31.6	70 31.4	+0.2	70 31.5	-3.4	70 28.1
78	Snaggy Mtn.	" 27	7.74	11:04	11:20	70 33.5	70 32.6	+0.9	70 33.1	-3.4	70 29.7

<sup>1</sup> Observations made purposely over a large gabbro rock projecting from the ground, in order to determine the effect.

TABLE XV.—Concluded.

Magnetic inclinations observed at various stations in Maryland between the years 1896 and 1899.

No.	Station.	Date.		Local mean time of observation.		Observed Inclinations.		Diff. I-II.	Mean Inclination.	Reduction to Jan. 1, 1900.	Inclination at Jan. 1, 1900.	
		Month and day.	Year and decimal 1890 +	I.	II.	I.	II.					
79	Taylor's Hill	Oct.	2	7.75	14:58	15:28	70 42.2 <sup>1</sup>	70 36.6	+5.6	70 40.3	-3.4	70 36.9
80	Flke's Hill, E.	"	8	7.77	16:14	16:30	70 41.9	70 41.8	+0.1	70 41.9	-3.3	70 38.6
81	" " W.	"	13	7.78	11:11	11:29	70 42.3	70 42.0	+0.3	70 42.1	-3.3	70 38.8
82	Mason and Dixon Line.	"	16	7.79	11:26	11:44	70 55.5	70 54.6	+0.9	70 55.0	-3.3	70 51.7
83	Lonaconing	Aug.	31	8.66	17:47	18:02	70 45.8	70 46.5	-0.7	70 46.2	-2.0	70 44.2
84	Gaithersburg, (Smith)	May	15	9.37	17:18	17:47	70 25.7	70 26.6	-0.9	70 26.2	-0.9	70 25.3
85	Lisbon	"	16	9.37	11:56	.....	71 23.6	.....	.....	71 23.6	-0.9	71 22.7
86	Sykesville	"	16	9.37	19:28	.....	70 53.3	.....	.....	70 53.3	-0.9	70 52.4
87	Relsterstown	"	17	9.38	12:13	.....	70 41.8	.....	.....	70 41.8	-0.9	70 40.9
88	Manchester	"	19	9.38	9:08	.....	70 59.2	.....	.....	70 59.2	-0.9	70 58.3
89	Taneytown	"	19	9.38	16:49	.....	71 01.0	.....	.....	71 01.0	-0.9	71 00.1
90	Liberty	"	20	9.38	10:39	11:11	70 49.6	70 50.9	-1.3	70 50.2	-0.9	70 49.3
91	McHenry	June	6	9.43	13:52	12:58	70 43.8	70 43.4	+0.4	70 43.6	-0.9	70 42.7
92	Accident	"	6	9.43	18:48	.....	70 46.3	.....	.....	70 46.3	-0.9	70 45.4
93	Grantsville	"	7	9.43	11:45	12:09	70 54.2	70 49.5	+4.7	70 51.8	-0.9	70 50.9
94	New Germany	"	8	9.44	12:16	11:52	70 50.4	70 51.1	-0.7	70 50.8	-0.8	70 50.0
95	Swanton	"	9	9.44	11:04	10:37	70 39.9	70 40.8	-0.9	70 40.4	-0.8	70 39.6
96	Paw Paw <sup>2</sup>	"	12	9.45	11:17	10:46	70 46.3	70 47.7	-1.4	70 47.0	-0.8	70 46.2
97	Parkton	"	14	9.45	13:23	13:00	70 57.3	70 59.5	-2.2	70 58.4	-0.8	70 57.6
98	Havre de Grace	"	20	9.47	11:37	11:17	70 57.9	70 59.1	-1.2	70 58.5	-0.8	70 57.7
99	Betterton	"	21	9.47	16:20	15:40	71 20.8	71 15.9 <sup>3</sup>	+5.0	71 18.4	-0.8	71 17.6
100	Rising Sun	"	22	9.47	12:48	11:58	71 12.8	71 12.6 <sup>3</sup>	+0.2	71 12.7	-0.8	71 11.9
101	Calvert	"	22	9.47	.....	16:48	.....	.....	.....	71 02.8	-0.8	71 02.0

<sup>1</sup> Weight two, mean of two determinations. <sup>2</sup> This station is in W. Va. <sup>3</sup> J. A. Fleming, observer.

TABLE XVI.

*Magnetic inclinations observed by the United States Coast and Geodetic Survey in the vicinity of Gaithersburg.*

No.	Station.	Date, Year and Decimal		Local Mean Time of Obsn's.			Observed Inclination.		Diff. I-II	Mean Inclination.	Reduction to Jan. 1, 1900.	Inclination at Jan. 1, 1900.	Observer.			
		Month and Day.	1890 +	I	II	I	II									
84A	Gaithersburg I.	July	69.51	h	m	h	m	70 44.4	70 40.1	+4.3	70 42.2	-.7	70 41.5	L. A. Bauer I.		
					13	20	14	37							H. W. Vehrenkamp II.	
					79.52	11	48	14	56	70 41.6	70 40.8	+0.8	70 41.2	-.7	70 40.5	" "
					109.52					70 50.6	70 46.1	+4.5	70 48.4	-.7	70 47.7	J. A. Fleming.
			249.56					70 41.8	70 44.2	-2.4	70 43.0	-.7	70 42.3	H. W. Vehrenkamp.		
													Mean.	70 43.0		
84B	Gaithersburg II		89.52	13	01	14	27	70 47.9	70 50.4	-2.5	70 49.2	-.7	70 48.5	H. W. Vehrenkamp.		
			119.52					70 52.6	70 46.1	+6.5	70 49.4	-.7	70 48.7	J. A. Fleming.		
													Mean.	70 48.6		
84C	Gaithersburg III		109.52	11	29	11	51	70 51.0	70 45.4	+5.6	70 48.2	-.7	70 47.5	H. W. Vehrenkamp.		
102	Waring . . . . .		139.53	10	36	11	31	71 47.1	71 45.5	+1.6	71 46.3	-.7	71 45.6	" "		
103	Middlebrook . . .		149.53	10	48	11	34	70 43.5	70 37.5	+6.0	70 40.5	-.7	70 39.8	" "		
104	Cross Roads I. . .		159.54	10	49	11	30	70 44.8	70 40.0	+4.8	70 42.4	-.7	70 41.7	" "		
105	Cross Roads II. .		179.54	11	09	11	51	70 42.4	70 36.4	+6.0	70 39.4	-.7	70 38.7	" "		
106	Redland . . . . .		189.54	10	56	11	37	70 25.6	70 20.9	+4.7	70 23.2	-.7	70 22.5	" "		
			189.54	15	09	15	54	70 26.9	70 20.9	+6.0	70 23.9	-.7	70 23.2	" "		
													Mean.	70 22.8		
107	Derwood . . . . .		199.55	10	57	11	35	70 20.4	70 13.9	+6.5	70 17.2	-.7	70 16.5	" "		
108	Hunting Hill . . .		209.55	11	04	11	50	71 02.8	70 58.4	+4.4	71 00.6	-.7	70 59.9	" "		
109	Quince Orchard . .		219.55	10	54	11	41	71 07.7	70 54.9 <sup>1</sup>	+2.8	70 59.2	-.7	70 58.5	" "		
67A	Seneca . . . . .		229.56	11	01	11	43	70 56.2	70 51.1	+5.1	70 53.6	-.7	70 52.9	" "		

<sup>1</sup> Result of two observations, weight = 2.

### THE DISTRIBUTION OF THE HORIZONTAL INTENSITY OF THE EARTH'S MAGNETIC FORCE FOR JANUARY 1, 1900.

#### METHOD OF OBSERVATION.

The absolute method of determining the horizontal intensity of the earth's magnetic force, *i. e.* deflection and oscillation observations, was followed throughout, except for special investigations of local disturbances when one or the other set of observations would be omitted. In addition absolute observations were repeatedly made at the base station, Linden, throughout the period of the survey.

With the values of the magnet moment derived at this station, it was possible by a proper interpolation taking into account the gradual loss in the magnetic moment with time, to compute two independent values of the horizontal intensity  $H$  at each station, one derived from the deflection sets and one from the oscillation observations. It is deemed best in magnetic survey work where instruments must be transported by wagons, railroad or steamboat to make absolute observations whenever possible so as to eliminate such errors as may be due to a sudden change of the magnetic moment caused in some manner during transportation of instrument.

The deflection observations were made almost entirely throughout the work with two distances, and as the observations extended over a good portion of the year, values of the magnetic moment were obtained at high and at low temperatures in the natural course of the field work. The distribution coefficient  $P$ , and the magnetic temperature coefficient could be derived, therefore, directly from the season's work. The remainder of the constants, such as moment of inertia of the long magnet used in declinations, vibrations, and as deflecting magnet in the deflection observations, and its induction coefficient, were repeatedly controlled throughout the work.

The instrument used was the Coast and Geodetic Survey magnetometer No. 18, illustrated and described in the First Report. It was compared with various European observatory magnetometers in the fall of 1899.

The values of the temperature coefficient,  $g$ , of the long magnet designated  $18L$  for  $1^{\circ}$  centigrade are:

Value.	Weight.	Observer and Remarks.
0.00053	2	G. R. Putnam, special obs'ns, Nov., 1893.
42	2	L. A. Bauer, 38 field observations, 1896.
42	2	L. A. Bauer, 36 field observations, 1897.
57	1	L. A. Bauer, 22 field observations, 1899.

Weighted mean 0.00047 adopted.

The deflection and the oscillation observations were arranged in such a manner as to refer as nearly as possible to the same temperature and intensity. The difference in temperature was rarely more

than 1°, generally less, so that an approximate value of  $q$  for absolute observations was ample.

The value of the distribution coefficient  $P$ , was from 48 field observations in 1896 and 1897,  $-0.68$  c. g. s. units, and from 37 field observations in 1898 and 1899,  $-0.67$  c. g. s. units. The first result was given the weight of 3 and the second 2 and the weighted mean

TABLE XVII.

*Mean diurnal variation of the magnetic horizontal intensity as derived from the continuous observations at the Washington Magnetic Observatory during the three years 1889-91.*

The quantities are expressed in units of 5th decimal C. G. S. system. The hours given are 75 Meridian Time, which is 8m. 12s. fast on local mean time. Plus sign means less, and minus sign greater than mean of day.

Month.	HOUR.																							
	A. M.												P. M.											
	1	2	3	4	5	6	7	8	9	10	11	12	1	2	3	4	5	6	7	8	9	10	11	12
Jan ...	-1	-2	-3	-6	-6	-6	-8	-7	-5	+7	+19	+22	+15	+8	+1	-4	-5	-6	-4	-2	-1	-1	-1	-1
Feb ...	+1	-1	-2	-3	-4	-5	-7	-5	-3	+1	+7	+10	+10	+6	+3	0	-2	-2	-1	0	+1	0	0	0
March..	-4	-4	-4	-5	-7	-6	-5	-1	+5	+12	+11	+11	+7	+3	-2	-3	-3	0	+1	0	-1	-2	-2	-3
April..	-4	-4	-4	-5	-6	-5	-2	+5	+14	+19	+18	+9	+5	-2	-7	-8	-7	-4	-1	-3	-3	-3	-3	-3
May ...	0	-1	-2	-2	-2	-4	+1	+9	+19	+22	+14	+3	-7	-12	-12	-8	-5	-2	-1	0	0	-1	-1	-1
June ..	-1	-1	-1	0	-2	-3	-1	+7	+14	+18	+14	+6	-3	-9	-11	-11	-6	-3	-1	0	-2	-1	-2	0
July ...	-3	-1	-2	0	-2	-3	-1	+6	+15	+20	+18	+9	-1	-7	-10	-11	-7	-3	-2	-1	-1	-2	-1	-2
Aug ...	-6	-5	-4	-3	-5	-5	-2	+10	+21	+24	+20	+10	0	-7	-10	-8	-5	-4	-2	-4	-4	-4	-3	-4
Sept...	-4	-6	-5	-6	-8	-7	-4	+7	+17	+23	+22	+15	+6	-1	-6	-7	-5	-3	-3	-3	-4	-4	-5	-5
Oct....	-6	-5	-7	-9	-10	-10	-6	+2	+14	+21	+22	+19	+10	+4	-1	-2	-1	-3	-3	-3	-3	-4	-5	-6
Nov ...	-1	-2	-3	-5	-7	-9	-6	-4	+4	+11	+13	+14	+10	+4	0	-3	-4	-2	-1	0	0	-2	0	-1
Dec ...	0	-1	-2	-4	-7	-8	-8	-8	-4	+3	+14	+17	+14	+8	+1	-3	-4	-3	-2	-1	0	+1	+2	+1
Mean ..	-2	-3	-3	-4	-6	-6	-4	+2	+9	+15	+16	+12	+6	0	-5	-6	-5	-3	-2	-1	-2	-2	-2	-2

of  $-0.676$  was adopted throughout the work. With this the value  $\log \left( 1 - \frac{P}{r^2} \right)$  for short distance, 35 cm., was 0.00024, and for long distance, 49 cm., was 0.00012.

REDUCTION TO JANUARY 1, 1900.

The secular change of the horizontal intensity as derived from a discussion of the Linden repeat observations, given in Table XVIII, and of the Coast and Geodetic Survey repeat observations in the vicinity of Maryland, was found to be a decrease in the horizontal intensity at an average annual rate of 0.00007 c. g. s. units or  $7 \gamma$ .

This value has been adopted for the present. Later values obtained since the discussion was made would indicate that the annual decrease may possibly be slightly more, 8 or 9  $\gamma$ . It is not deemed advisable, however, to make any change now in the referred quantities. A definite value will hardly be obtainable before 1905.

The same method of elimination of diurnal change had to be employed as in the case of the inclination. Table XVII, derived from Table XI of the previous chapter, gives the corrections to be applied to an observed quantity. If there was evidence of a large magnetic disturbance variation, the observations were either suspended or if made were finally omitted. There were only a few such.

As in the case of the inclination and for the same reasons as there stated, the corrections given in Table XVII do not strictly apply to the period of the survey. It was found, however, that although the corrections are in general small, it paid to apply them, a reduction of the probable error of a single result resulting therefrom.

Figs. 4, 5 and 6 represent by curves the diurnal changes, respectively in the horizontal, vertical and total intensity. They are taken from the publications of the Magnetic Observatory of the United States Naval Observatory (before its removal to the new site) for 1887, Appendix 2.

#### THE ACCURACY OF THE OBSERVATIONS.

Looking over the residuals—the differences of the separately observed values of  $H$  at Linden from the mean of all—given in the last column of Table XVIII, we notice that they, in general, do not amount to over 2 in the fourth decimal and occasionally they are about 4. The *mean square error* of a single result, as due to a combination of observing and reduction error, diurnal variation, disturbance variation, annual variation and secular change, is:

$$\mu = \sqrt{\frac{[vv]}{n-1}} = \pm 24\gamma = \frac{1}{800} H$$

and the probable error of a single result is:

$$\epsilon = \pm .6745 \sqrt{\frac{[vv]}{n-1}} = \pm 16\gamma = \frac{1}{1040} H.$$



In addition to the combination of errors involved in these figures, we have in addition reason to suspect that certain instrumental changes may have taken place. Thus during these observations the magnetometer was provided with *wooden* deflection bars instead of with metallic ones as now. These wooden bars have been shown to change their shape and dimensions with varying conditions of moisture and distance sufficient to produce a change in the deflecting distance, causing an error of  $1/1000 H$  in the result—*i. e.* about the same order as the above errors. Furthermore a study of the instrument showed that the limit of accuracy attainable in a single observed result at any time was about  $1/1000 H$ . The Coast and Geodetic Survey is now procuring instruments with which a higher degree of accuracy can be obtained than with its past instruments. However, for the general purposes of the magnetic survey the accuracy obtained will suffice.

## TABLES.

No further explanation than that given in the headings of the columns will presumably be required. Tables XVIII, XIX and XX give the values of the horizontal intensity for Maryland while the recent values obtained in the vicinity of its boundaries will be found in Table X.

In order to avoid the decimal point, the values are expressed in terms of gammas (see p. 65) or in units of the fifth decimal c. g. s. The dimensions of  $\gamma$  are those of intensity not of force or dyne. The intensity of a magnetic field being the force which a unit pole will experience when placed in it, its dimensions are

$$M^{1/2} L^{-1/2} I^{-1} \text{ or } g^{1/2} \text{ cm}^{-1/2} s^{-1}$$

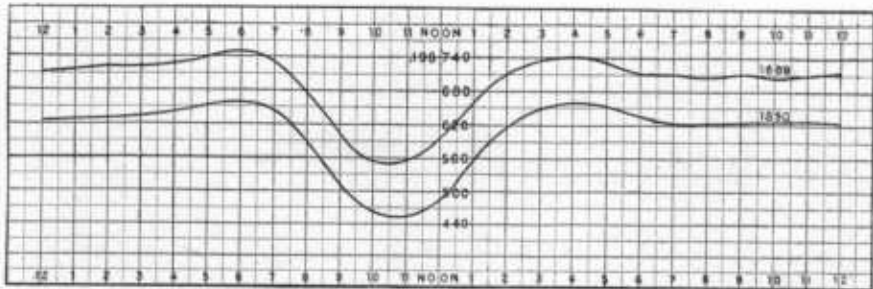

FIG. 4.—The diurnal variation of the horizontal intensity at Washington, D. C. (1889-1890).

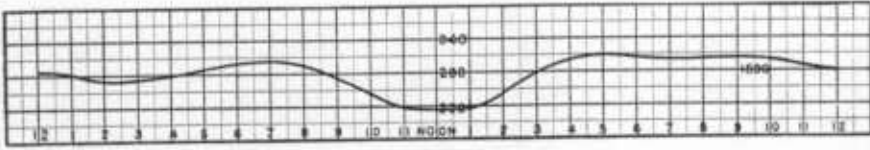

FIG. 5.—The diurnal variation of the vertical intensity at Washington, D. C. (1890).

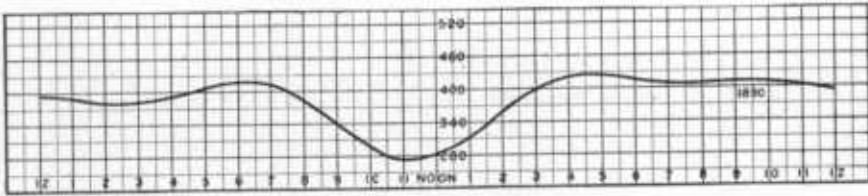

FIG. 6.—The diurnal variation of the total intensity at Washington, D. C. (1890).

TABLE XVIII.

Values of the horizontal intensity observed at Base Station, Linden, Montgomery County, between the years 1896 and 1900.

[All observations by L. A. Bauer except Nos. 23, 24, 25, and 26, which were made by J. A. Fleming.]

No. of Obs'n.	Date.		Local Mean Time.		Magnetic Moment at 16° 7' C.	Horizontal Intensity Observed.	Reduction to Jan. 1, 1900.	Horizontal Intensity on Jan. 1, 1900.	Difference from mean.
	Month and Day.	Year and Decimal. 1890+	Osc.	Defl.					
1	July 15-29.	6.55	.....	.....	321.84	19791 <sup>1</sup>	-24	19767	- 7
2	Sept. 7....	6.68	15 52	16 25 <sup>1</sup>	320.09	825	-23	802	-42
3	" 28....	6.74	14 59	15 55	319.23	762	-23	739	+21
4	Oct. 4....	6.76	15 51	16 51	319.02	827	-23	804	-44
5	" 30....	6.83	14 22	15 21	318.92	792	-22	770	-10
6	" 30....	6.83	16 52	15 47	319.37	773	-22	751	+ 9
7	" 31....	6.83	10 55	10 32 <sup>2</sup>	318.93	777	-22	755	+ 5
8	Nov. 24....	6.90	9 30	11 35	319.68	767	-22	745	+15
9	" 24....	6.90	12 03	13 14	319.46	786	-22	764	- 4
10	" 24....	6.90	14 18	14 53	319.29	795	-22	773	-13
11	Apr. 14....	7.28	10 11 } 11 44 }	11 18	319.70	745	-19	726	+34
12	June 21....	7.47	9 07	9 50	317.76	803	-18	785	-25
13	" 21....	7.47	15 32	15 54	317.23	796	-18	778	-18
14	July 23....	7.56	8 58	9 27	317.23	757	-17	740	+20
15	" 23....	7.56	18 08	18 40	317.04	755	-17	738	+22
16	" 24....	7.56	8 16	8 42	316.96	759	-17	742	+18
17	" 24....	7.56	18 36	19 17	316.25	782	-17	765	- 5
18	Sept. 18....	8.72	9 29 } 10 25 }	10 00	311.17	734	-09	725	+35
19	" 19....	8.72	6 46 } 8 16 }	7 17	311.04	761	-09	752	+ 8
20	May 10....	9.36	11 27 } 13 31 }	12 30	308.67	776	-04	772	-12
21	" 12....	9.36	10 37 } 12 11 }	11 28	308.33	769	-04	765	- 5
22	" 15....	9.37	11 05	11 35	308.47	780	-04	776	-16
23	July 5....	9.51	13 38 } 14 53 }	14 15	307.77	720	-03	717	+43
24	" 6....	9.51	9 36 } 10 47 }	10 12	307.71	735	-03	732	+23
25	" 7....	9.52	8 55 } 10 06 }	9 29	307.31	755	-03	752	+ 8
26	" 8....	9.52	8 05 } 9 33 }	8 49	307.15	745	-03	742	+18
27	" 18....	10.55	17 07	16 59	300.97	768	+04	772	-12
28	" 19....	10.55	16 48	16 48	301.58	768	+04	772	-12
29	" 20....	10.55	9 24	9 26	302.14	19803	+04	807	-47
Mean .....								19760	

<sup>1</sup> Mean of five practice sets.

<sup>2</sup> Deflection observations made with one distance only.

TABLE XIX.

Values of the horizontal intensity observed at various stations in Maryland between the years 1896 and 1899, reduced to January 1, 1900.

[All observations by L. A. Bauer.]

No.	Station.	Date.		Local mean time.		Magnetic moment at 16° 7 C.	Hor. Intensity observed.	Reduction to Jan. 1, 1900.	Horizontal intensity at Jan. 1, 1900.
		Month and day.	Year and decimal 1890 +	Osc. ns.	Def. ns.				
42	Forest Glen .....	July 20	6.55	12 54	h. m. . . .	[321.84]	20058	-24	20034
	" " .....	Nov. 25	6.90	10 29	11 08	320.17	19961	-22	19939
Mean . . . .									19986
2	Upper Marlboro .....	Sept. 9	6.69	17 07	} 11 23	320.29	20220	-23	20197
3	La Plata .....	" 10	6.69	10 43			11 20	320.39	20601
	" .....	June 3	7.42	17 10	17 47	318.39	20569	-18	20551
Mean . . . .									20564
5	Mechanicsville .....	Sept. 11	6.69	11 33	..	[320.01]	20439	-23	20416
6	Lenardtown .....	" 12	6.70	8 55	9 40	319.34	20864	-23	20841
7	Easton, Hotel .....	" 16	6.71	15 35	16 23	320.22	20346	-23	20323*
7A	" F. G. ....	June 24	7.48	15 43	..	[317.50]	20301	-18	20283
8	Centreville, Acad. ....	Sept. 17	6.71	15 58	16 46	319.85	20147	-23	20124
	" " .....	May 27	7.40	16 13	16 40	318.05	20106	-18	20088
Mean . . . .									20106
8A	" C. H. ....	" 27	7.40	..	13 40	[318.05]	20242	-18	20224*
9	Massey .....	Sept. 18	6.72	10 56	11 38	319.21	19774	-23	19751
10	Ridgely .....	" 19	6.72	8 34	8 54	319.54	20158	-23	20135
11	Hurlock .....	" 19	6.72	17 00	16 46	319.65	20400	-23	20377
12	Ocean City .....	" 21	6.72	15 50	17 09	319.58	20376	-23	20353
13	Berlin .....	" 23	6.73	9 52	10 34	319.11	20538	-23	20515
14	Snow Hill .....	" 23	6.73	15 40	16 21	318.30	20692	-23	20669
15	Pocomoke City .....	" 24	6.73	10 14	10 49	319.41	20646	-23	20623
16	Princess Anne .....	" 24	6.73	16 38	17 18	320.03	20566	-23	20543
17	Salisbury, C. H. ....	" 25	6.73	10 48	12 22	320.14	20449	-23	20426
18	Parsonsburg .....	" 25	6.73	14 22	14 41	318.61	20445	-23	20422
19	Cockeysville .....	" 26	6.74	14 38	15 00	319.07	19628	-23	19605
20	Frederick, Asy. ....	Oct. 5	6.76	15 50	17 20	319.27	19904	-23	19881
20A	" C. H. ....	" 7	6.77	15 55	16 27	319.30	19974	-23	19951*
21	Westminster .....	" 8	6.77	15 47	16 24	318.98	20187	-23	20164
22	Hagerstown .....	" 9	6.77	15 23	15 37	318.65	19669	-23	19646
23A	Cumberland .....	" 10	6.77	16 22	16 57	319.05	19825	-23	19802
24	Oakland, S. H. ....	" 12	6.78	9 35	9 08	318.32	20120	-23	20097 <sup>2</sup>
	" " .....	" 12	6.78	13 09	13 46	318.62	20185	-23	20162 <sup>2</sup>
24A	Oakland, C. H. ....	Aug. 2	7.59	10 00	10 36	316.88	20119	-17	20102
	" " .....			9 03	} 9 35	308.94	20096	-04	20092
	" " .....	June 5	9.43	10 01					
Mean . . . .									20097
25	Point of Rocks .....	Oct. 13	6.78	10 23	10 58	318.62	19997	-23	19974
26	Dickerson .....	" 13	6.78	14 18	14 48	318.48	19679	-23	19656
27	Elkton .....	" 15	6.79	10 06	11 18	319.29	19846	-22	19824
28	Prince Fredericktown	" 17	6.79	16 45	17 24	319.29	20634	-22	20612
29	Belair, Hotel .....	" 20	6.80	11 17	12 39	319.04	20176	-22	20154
	" " .....	" 20	6.80	13 50	12 39	318.85	20161	-22	20139
	" " .....	May 7	7.35	9 40	10 33	318.35	20154	-19	20135
Mean . . . .									20143
30	Annapolis .....	Oct. 21	6.81	14 57	15 30	318.82	20041	-22	20019
31	Ellicott City .....	" 22	6.81	16 09	16 41	318.81	20064	-22	20042
32	Baltimore .....	Nov. 4	6.84	15 35	16 14	319.96	19602	-22	19580
33	Belcamp .....	" 6	6.85	1 11	12 47	319.40	19467	-22	19445

<sup>1</sup> Bracketed quantities are interpolated values; either deflections or oscillations were not observed for these cases. <sup>2</sup> Severe magnetic storm. \* Artificial local disturbance.

TABLE XIX.—Continued.

Values of the horizontal intensity observed at various stations in Maryland between the years 1896 and 1899, reduced to January 1, 1900.

No.	Station.	Date.		Local mean time.		Magnetic moment at 16° 7 C.	Hor. Intensity observed.	Reduction to Jan. 1, 1900.	Horizontal intensity at Jan. 1, 1900.
		Month and day.	Year and decimal 1890 +	Osc'n.	Def'ns.				
37	Cardiff, R. R. ....	Nov. 7	6.85	h. m. 11 15	h. m. .. ..	[319.65]	19494	-22	19472
37B	" B. St. ....	May 4	7.37	9 55	10 09	317.46	19065	-18	19047
37E	" Slate Q. ....	" 14	7.37	.. ..	11 36	[317.74]	19849	-18	19831
37J	" S. H. ....	" 14	7.37	8 39	.. ..	[317.74]	20108	-18	20090
38	Forest Hill. ....	Nov. 7	6.85	14 37	15 25	319.90	19546	-22	19524
40	Unity. ....	" 14	6.87	10 26	10 56	319.87	20057	-22	20035
41	Damascus. ....	" 14	6.87	15 44	17 28	319.26	19738	-22	19716
1A	Linden, A. S. ....	" 25	6.90	15 50	16 16	319.17	20003	-22	19981
43	Crisfield. ....	Dec. 7	6.93	10 16	10 39	320.67	20660	-21	20639
	" .....	" 7	6.93	11 17	10 39	318.72	20786	-21	20765
	" .....	" 7	6.93	14 05	14 24	320.04	20739	-21	20718
	" .....	" 7	6.93	14 46	14 24	319.37	20772	-21	20751
							Mean..	....	20718
44	Cambridge. ....	Apr. 17	7.29	17 13	17 38	318.32	20489	-19	20470
				11 10					
45	Tilghman Is. ....	" 19	7.30	14 24	11 38	317.83	20475	-19	20456
46	Woodstock. ....	" 23	7.31	16 38	17 12	317.82	19707	-19	19688
47	Towson, N. M. ....	" 24	7.31	13 36	14 24	318.13	19628	-19	19609
47A	" S. M. ....	" 26	7.32	17 40*	8*38	317.96	19577	-19	19558
							Mean..	....	19584
48	Hyde's. ....	May 7	7.35	.. ..	17 32	[317.99]	19589	-19	19570
49	Churchville. ....	" 8	7.35	11 20	11 35	318.00	19515	-19	19496
50	Thomas Run. ....	" 8	7.35	14 30	14 48	318.11	19921	-19	19902
52	Highland Mines. ....	" 14	7.37	.. ..	14 37	[317.74]	19676	-18	19658
53	Minefield. ....	" 14	7.37	17 08	.. ..	[317.74]	19066	-18	19048
54	Dublin. ....	" 15	7.37	18 59	.. ..	[317.74]	18620	-18	18602
56	Bradshaw. ....	" 20	7.38	.. ..	16 40	[317.74]	19285	-18	19267
57	Chestertown, N. M. ...	" 29	7.41	14 09	14 39	317.93	20043	-18	20025*
57A	" Wash. Col. ....	" 31	7.41	16 41	17 11	317.57	20029	-18	20011
58	Tolchester. ....	June 1	7.42	17 05	.. ..	[317.50]	19707	-18	19689
59	Oxford. ....	" 25	7.48	15 02	15 26	316.97	20481	-18	20463
60	Fair Haven. ....	" 26	7.49	11 48	1 14	318.04	20370	-18	20352
61	Laurel. ....	July 1	7.50	15 05	.. ..	[316.87]	19845	-18	19827
63	Webb. ....	" 16	7.54	17 04	17 41	316.39	19939	-17	19922
64	Kent I., S. B. ....	" 19	7.55	11 48	12 26	315.94	20151	-17	20132
65	" Stevensville. ....	" 20	7.55	8 36	.. ..	[316.17]	19954	-17	19937
67	Seneca. ....	" 26	7.57	15 25	.. ..	[316.81]	19824	-17	19807
68	Maryland Helghts. ...	" 27	7.57	15 48	16 11	316.86	19916	-17	19899
68A	" " Hughes. ....	" 28	7.57	10 09	10 32	316.68	19873	-17	19856
69	Hancock. ....	" 28	7.57	15 57	16 27	316.65	19716	-17	19699
70	Corunna. ....	" 31	7.58	11 54	12 37	316.74	20182	-17	20165
71	Westernport. ....	Aug. 3	7.59	15 45	15 55	316.70	19982	-17	19965
72A	Fairfax Mon. ....	" 5	7.59	9 56	10 27	316.68	20213	-17	20196
	" " .....	" 5	7.59	13 44	14 34	314.90	20194	-17	20177
	" " .....	" 6	7.60	13 40	14 15	316.31	20244	-17	20227
							Mean..	-17	20200
				8 57					
73	Camp Fairfax. ....	" 7	7.60	15 27	10 10	316.26	20260	-17	20243
74	Backbone Mtn. ....	Sept. 1	7.67	15 26	15 34	316.21	20200	-16	20184
76	Foley Mtn. ....	" 21	7.72	11 24	11 48	315.34	20161	-16	20145

\*Artificial local disturbance.

TABLE XIX.—Concluded.

Values of the horizontal intensity observed at various stations in Maryland between the years 1896 and 1899, reduced to January 1, 1900.

No.	Station.	Date.		Local mean time.		Magnetic moment at 16° 7 C.	Hor. Intensity observed.	Reduction to Jan. 1, 1900.	Horizontal intensity at Jan. 1, 1900.
		Month and Day.	Year and decimal 1890 +	Osc'ns.	Def'ns.				
77	Lower Hill . . . . .	Sept. 25	7.73	h. m. 17 10	h. m. 17 49	316.85 <sup>1</sup>	γ 20163	γ -16	γ 20147
78	Snaggy Mtn. . . . .	" 28	7.74	14 30	14 53	315.57	20121	-16	20105
79	Taylor's Hill . . . . .	Oct. 2	7.75	10 23	10 51	315.73	20059	-16	20087
80	Fike's Hill, E. . . . .	" 8	7.77	15 16	15 44	315.79	20088	-16	20022
81	" " W. . . . .	" 13	7.78	13 49	13 21	315.81	20049	-16	20033
82	Mason and Dixon Line	" 16	7.79	10 53	11 19	315.36	19951	-15	19936
83	Lonaconing . . . . .	Aug. 31	8.66	16 34	16 34	312.53 <sup>1</sup>	19995	-09	19986
84	Gaithersburg . . . . .	May 15	9.37	15 58	16 37	308.32	19915	-04	19911
85	Lisbon . . . . .	" 16	9.37	11 02	11 25	308.75	19719	-04	19715
86	Sykesville . . . . .	" 16	9.37	16 22	16 50	308.38	20039	-04	20035
87	Relsterstown . . . . .	" 17	9.38	11 13	11 40	308.96	20193	-04	20189
88	Manchester . . . . .	" 19	9.38	8 07	8 35	308.46	19681	-04	19677
89	Taneytown . . . . .	" 19	9.38	15 32	16 06	307.95	19629	-04	19625
90	Liberty . . . . .	" 20	9.38	8 13 } 9 14 }	8 51	308.46	19765	-04	19761
91	McHenry . . . . .	June 6	9.43	11 04	11 34	308.62	19944	-04	19940
92	Accident, S. H. . . . .	" 6	9.43	17 36	18 04	309.89	19867	-04	19863
93	Grantsville . . . . .	" 7	9.43	13 47	14 23	308.57	19889	-04	19885
94	New Germany . . . . .	" 8	9.44	9 12	9 40	308.55	19873	-04	19869
95	Swanton . . . . .	" 9	9.44	9 16	9 48	308.79	20058	-04	20054
96	Paw Paw, W. Va. . . . .	" 12	9.44	9 22	9 57	308.08	19806	-04	19802
97	Parkton . . . . .	" 14	9.45	11 54 } 8 43 }	12 13	308.44	19555	-04	19551
98	Havre de Grace . . . . .	" 20	9.47	9 43 }	9 17	308.77 <sup>1</sup>	19391	-04	19387
99	Betterton . . . . .	" 21	9.47	11 26 } 12 17 }	12 17	308.13 <sup>1</sup>	19320	-04	19316
	" . . . . .	" 21	9.47	14 20 } 14 49 }	14 49	307.72 <sup>1</sup>	19303	-04	19299
100	Rising Sun . . . . .	June 22	9.47	9 11	9 59	308.77 <sup>1</sup>	Mean . . . . .		19308
101	Calvert . . . . .	" 22	9.47	4 11	4 31	308.17 <sup>1</sup>	19585	-04	19579
							19528	-04	19524

<sup>1</sup>Thermometer defective.

Artificial local disturbance.

TABLE XX.

Values of the horizontal intensity observed by the United States Coast and Geodetic Survey in the vicinity of Gaithersburg, reduced to Jan. 1, 1900.

Station.	Date.		Local Mean Time.		Horizontal Intensity Observed.	Reduction to Jan. 1, 1900.	Horizontal Intensity at Jan. 1, 1900.	Observer.	
	Month and Day.	Year and Decimal. 1800 +	Osc.	Defl.					
Gaithersburg I...	July	7..	9.52	h m 8 29 10 43	9 18	19783	-3	19780	H. W. Vehrenkamp.
	"	10..	9.52	8 26 9 32	9 00	19807	-3	19804	J. A. Fleming.
	"	24..	9.56	8 16 9 35	9 24	19758	-3	19750	H. W. Vehrenkamp.
					Mean	...		19778	
Gaithersburg II..	"	8..	9.52	9 54 11 13	1040	19743	-3	19740	H. W. Vehrenkamp.
	"	11..	9.52	8 26 9 34	9 02	19705	-3	19702	J. A. Fleming.
					Mean	...		19721	
Gaithersburg III.	"	10..	9.52	8.29 9.38	9 13	19771	-3	19768	H. W. Vehrenkamp.
Waring .....	"	13..	9.53	8.50 9.52	9 26	18806	-3	18803	" "
Middlebrook .....	"	14..	9.53	8 57 10 05	9 34	19828	-3	19825	" "
Cross Roads I ...	"	15..	9.54	8 17	9 16	20128	-3	20125	" "
Cross Roads II ..	"	17..	9.54	8 09 9 38	8 58	20180	-3	20177	" "
Redland .....	"	18..	9.54	8 00 9 33	9 02	20089	-3	20086	" "
Derwood .....	"	19..	9.55	8 06 9 34	8 40	20379	-3	20376	" "
Hunting Hill....	"	20..	9.55	8 25 9 35	9 04	19854	-3	19851	" "
Quince Orchard..	"	21..	9.55	8 21 9 28	8 54	19663	-3	19660	" "

MAP OF THE LINES OF EQUAL HORIZONTAL INTENSITY FOR  
JANUARY 1, 1900.

Plate V.

The graphical method was, at present, pursued as in the case of the other elements. A small preliminary map as based on the 1896 observations was published in the First Report which, of course, is superseded by the present one based on all observations up to date. It will be seen that the three isomagnetic maps unite in exhibiting the regional disturbances in central and northeastern Maryland. A preliminary examination has already shown that a comparative study of these disturbances with the geological formations will prove of interest and value. The Coast and Geodetic Survey is pursuing the investigation of these disturbances in the surrounding states. For this reason it will be advisable to postpone the subject until the completion of that work.

THE MAGNETIC ELEMENTS AND COMPONENTS IN MARYLAND FOR  
JANUARY 1, 1900.

In Table XXI are summarized from the previous tables all the values of the magnetic elements, declination, inclination and horizontal intensity, referred to January 1, 1900, which are available for the analysis of the local forces disturbing the distribution of magnetism within the State of Maryland. Those values which were indicated in the previous tables as disturbed by too close proximity to some artificial disturbing influence have been omitted; there were but few such cases. The quantities desired for the proposed analysis are the "magnetic components" derived from the magnetic elements ( $D, I, H$ ) as follows:

Component directed due north:

$$X = H \cos D, \dots \dots \dots (1)$$

Component directed due west:

$$- Y = H \sin D, \dots \dots \dots (2)$$

Component directed vertically downwards:

$$Z = H \tan I, \dots \dots \dots (3)$$

Total component:

$$W = H \sec I = \sqrt{X^2 + Y^2 + Z^2} \dots (4)$$



$Y$  is positive when directed towards the east, i. e., when the magnetic declination is east; when the declination is west, as it is over the center state,  $Y$  is negative. The values of  $H$ ,  $X$ ,  $Y$ ,  $Z$  and  $W$ , in order to avoid decimal points are again expressed in gammas (see pp. 65 and 82).

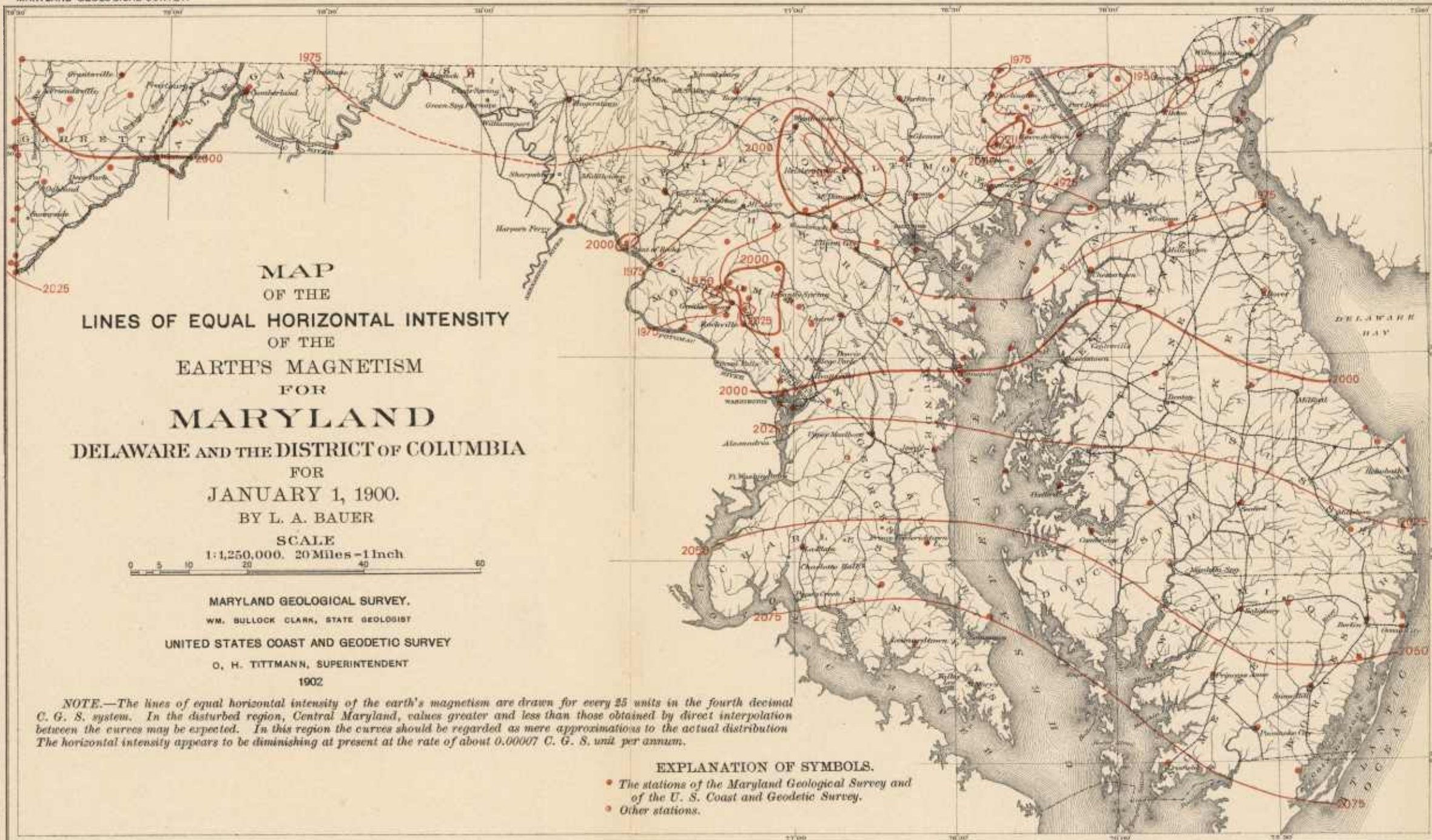

MAP  
OF THE  
LINES OF EQUAL HORIZONTAL INTENSITY  
OF THE  
EARTH'S MAGNETISM  
FOR  
**MARYLAND**  
DELAWARE AND THE DISTRICT OF COLUMBIA  
FOR  
JANUARY 1, 1900.

BY L. A. BAUER

SCALE  
1:1,250,000. 20 Miles = 1 Inch

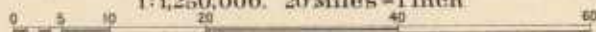

MARYLAND GEOLOGICAL SURVEY.  
WM. BULLOCK CLARK, STATE GEOLOGIST  
UNITED STATES COAST AND GEODETIC SURVEY  
O. H. TITTMANN, SUPERINTENDENT  
1902

*NOTE.*—The lines of equal horizontal intensity of the earth's magnetism are drawn for every 25 units in the fourth decimal C. G. S. system. In the disturbed region, Central Maryland, values greater and less than those obtained by direct interpolation between the curves may be expected. In this region the curves should be regarded as mere approximations to the actual distribution. The horizontal intensity appears to be diminishing at present at the rate of about 0.00007 C. G. S. unit per annum.

EXPLANATION OF SYMBOLS.

- The stations of the Maryland Geological Survey and of the U. S. Coast and Geodetic Survey.
- Other stations.

P. 90 B

P. 90 B

TABLE XXI.  
The magnetic elements and components in Maryland for January 1, 1900, arranged alphabetically according to county.

No.	STATION.	Position.			Mag.'s Elements, Jan. 1, 1900.				Mag.'s Components, Jan. 1, 1900.				County.
		Lat. N.	Long. W. of Gr	W. Decl'n. D	Incl'n. I	Hor. I. H	North X	West -Y	Vert'l Z	Total W			
71	Westernport .....	39 28.9	79 02.2	3 53.4	70 47.4	19065	19919	1354	57299	60678	Allegany		
96	Paw Paw, W. Va. ....	39 32.1	78 26.2	4 12.4	70 46.2	19802	19749	1452	56768	60123			
83	Lonaconing .....	39 33.6	78 59.1	3 55.0	70 44.2	19986	19939	1365	57189	60580			
25A	Cumberland, M. L. ....	39 39.2	78 46.4	4 13.5	70 54.6	19802	19748	1459	57218	60547			
129 to 121	inclusive .....	39 32.0	79 01.9	3 56.7	70 50.0	.....	.....	.....	.....	.....	Anne Arundel		
120 to 111	" .....	39 39.9	78 57.0	4 06.0	70 08.6	20352	20258	1955	56355	59918			
60	Fairhaven .....	38 45.4	76 33.4	5 30.7	70 30.5	.....	.....	.....	.....	.....			
66	Bay Ridge .....	38 56.2	76 27.2	5 25.7	70 34.7	20019	19929	1894	56788	60214			
30	Annapolis .....	38 58.9	76 29.1	5 09.7	70 39.3	19922	19841	1792	56745	60141			
63	Webb .....	39 05.3	76 40.5	5 32.1	70 55.1	19580	19439	1888	56602	59894			
32	Baltimore, Fort .....	39 15.9	76 34.9	5 54.6	70 51.9	19584	19480	2016	56443	59745			
47 & 47A	Towson .....	39 24.0	76 36.4	5 26.7	71 13.1	19267	19180	1828	56655	59843			
56	Bradshaw .....	39 25.3	76 22.6	7 04.5	70 40.9	20187	20033	2486	57585	61021	Baltimore		
87	Reisterstown .....	39 27.8	76 50.0	5 52.7	70 45.0	19570	19467	2004	56040	59358			
48	Hyde's .....	39 29.1	76 29.2	6 11.9	70 55.3	19605	19490	2117	56685	59981			
19	Cockeysville .....	39 29.1	76 38.6	6 00.7	70 57.6	19551	19443	2048	56651	59931			
97	Parkton .....	39 39.0	76 40.0	5 20.0	69 52.7	20612	20523	1916	56259	59916	Calvert		
28	Prince Frederick .....	38 32.4	76 34.9	5 53.5	.....	.....	.....	.....	.....	.....			
132	Denton .....	38 33.3	75 52.0	5 54.1	70 22.9	20135	20028	2070	56489	59969	Caroline		
10	Ridgely .....	38 57.4	75 52.6	6 25.9	70 52.4	20035	19909	2244	57771	61146			
86	Sykesville .....	39 22.3	76 57.7	5 36.6	70 58.3	19677	19583	1923	57055	60353			
88	Manchester .....	39 39.6	76 52.8	4 59.7	71 00.1	19625	19551	1709	57001	60285	Carroll		
80	Taneytown .....	39 39.5	77 10.7	5 16.6	70 29.3	20164	20078	1854	56905	60373			
21	Westminster .....	39 34.6	76 59.7	4 45.2	.....	.....	.....	.....	.....	.....	Cecil		
21A & B	Westminster .....	39 34.6	76 59.7	4 45.2	.....	.....	.....	.....	.....	.....			
27	Elkton .....	39 36.5	75 49.5	5 21.6	70 52.6	19824	19737	1852	57173	60512			
100	Rising Sun .....	39 41.5	76 03.3	5 10.4	71 11.9	19379	19499	1765	57507	60749			
101	Calvert .....	39 41.8	75 57.7	5 27.6	71 02.0	19524	19435	1858	56809	60070			
3	La Plata .....	38 31.8	76 58.7	4 46.8	69 58.0	20564	20493	1714	56398	60029	Charles		



TABLE XXI.—Continued.  
The magnetic elements and components in Maryland for January 1, 1900, arranged alphabetically according to county.

No.	STATION.	Position.			Mag'c Elements, Jan. 1, 1900.				Mag'c Components, Jan. 1, 1900.				County.
		Lat. N.	Long. W. of Gr.	W. Decl'n. D.	Incl'n. I.	Hor. I. H.	North X.	West -Y.	Vert'l Z.	Total W.			
44	Cambridge.....	38 34.3	76 04.6	5 32.1	69 55.4	20470	20375	1974	56008	59632	Dorchester		
11	Hurlock.....	38 38.0	75 52.7	5 34.7	70 02.7	20377	20281	1981	56123	59708			
25	Point of Rocks.....	39 16.3	77 32.1	.....	70 42.4	19974	.....	.....	57057	60452	Frederick		
90	Frederick, Asy.....	39 24.7	77 24.8	4 51.9	70 42.2	19881	19809	1686	56782	60162			
90	Liberty.....	39 29.0	77 13.9	4 49.1	70 49.3	19761	19691	1660	56815	60153			
70	Corunna.....	39 16.6	79 22.6	3 23.5	70 35.8	20165	20130	1193	57251	60699			
24A	Oakland C. H.....	39 24.0	79 24.0	3 28.8	70 55.2	20096	20059	1220	57023	60460			
95	Swanton.....	39 27.0	79 12.3	3 38.3	70 39.6	20054	20013	1273	57137	60555	Garrett		
91	McHenry.....	39 33.4	79 21.2	3 38.0	70 42.7	19940	19900	1264	56977	60366			
92	Accident.....	39 37.6	79 19.0	3 46.5	70 45.4	19863	19820	1308	56900	60267			
94	New Germany.....	39 37.9	79 07.2	4 00.7	70 50.0	19869	19820	1390	57164	60519			
98	Grantsville.....	39 41.6	79 09.1	4 00.1	70 50.9	19885	19837	1388	57257	60612			
72	Fairfax Store.....	39 11.6	79 29.2	3 16.4	.....	.....	.....	.....	.....	.....			
72A	".....	39 11.7	79 29.2	3 12.4	70 25.2	20200	20168	1130	56791	60277			
73	Camp Fairfax.....	39 12.7	79 29.0	3 13.0	70 30.8	20248	20211	1136	57206	60682			
74	Backbone Mtn.....	39 14.1	79 29.2	3 14.0	70 25.2	20184	20152	1138	56747	60230			
75	Camp Potomac.....	39 13.0	79 30.4	.....	70 28.1	.....	.....	.....	.....	.....	Garrett (Western Boundary Line)		
76	Foley Mtn.....	39 20.8	79 30.4	3 22.8	70 28.1	20145	20110	1188	56788	60256			
77	Lower Hill.....	39 21.9	79 29.2	3 23.5	.....	20147	20112	1192	.....	.....			
78	Snaggy Mtn.....	39 29.1	79 29.2	3 44.0	70 29.7	20105	20062	1309	56758	60214			
79	Taylor's Hill.....	39 30.0	79 30.4	3 38.5	70 36.9	20087	20047	1276	57089	60519			
80	Fike's Hill, E.....	39 34.7	79 29.2	3 47.0	70 38.6	20022	19978	1321	56993	60407			
81	" " W.....	39 33.9	79 30.4	3 47.1	70 38.8	20033	19989	1322	57035	60452			
82	Mason & Dixon Line.....	39 43.3	79 29.2	3 54.1	70 51.7	19936	19890	1356	57447	60808			
33	Belcamp.....	39 28.2	76 14.4	6 15.1	71 01.9	19445	19330	2117	56574	59823			
34	Harford Furnace.....	39 29.8	76 15.7	.....	70 59.3	.....	.....	.....	.....	.....	Harford		
35	Creswell.....	39 31.4	76 17.3	.....	71 02.9	.....	.....	.....	.....	.....			
29	Belair, Hotel.....	39 31.9	76 20.8	5 50.3	70 20.2	20143	20038	2049	56870	59860			
29A	" Dallam.....	39 31.9	76 20.7	4 45.1	70 10.6	.....	.....	.....	.....	.....			

TABLE XXI.—Continued.  
The magnetic elements and components in Maryland for January 1, 1900, arranged alphabetically according to county.

No.	STATION.	Position.			Mag's Elements, Jan. 1, 1900.				Mag's Components, Jan. 1, 1900.				County.
		Lat. N.	Long. W. of Gr.	Decl'n. W. D.	Incl'n. I.	Hor. I. H.	North X.	West -Y.	Vert'l Z.	Total W.			
98	Havre de Grace.....	39 32.4	76 05.1	5 26.0	70 57.7	10387	19300	1826	56181	59432			
36	Fountain Green.....	39 32.6	76 18.4		70 43.6								
49	Churchville.....	39 33.6	76 15.1	5 51.3	70 51.8	19490	19395	1988	56155	59472			
38	Forest Hill.....	39 34.9	76 23.9	5 38.9	71 01.3	19524	19432	1893	56804	60066			
51	Hickory.....	39 35.1	76 19.8		71 22.8								
50	Thomas Run.....	39 35.4	76 16.9	5 45.8	70 39.3	19093	19802	1999	56689	60081			
55	Scarboro.....	39 38.9	76 17.3		70 35.3								
54	Dublin.....	39 39.1	76 15.7	10 08.8	72 11.3	18602	18311	3277	57898	60814			
53	Minfield.....	39 39.2	76 22.3	7 01.6	72 00.9	19048	18905	2330	58676	61691			
52	Highland.....	39 40.5	76 22.1	5 41.1	70 59.8	19658	19561	1947	57081	60871			
37	Cardiff, R. R.....	39 43.3	76 20.1	4 35.3	71 11.5	19472	19410	1558	57172	60396			Harford
37A	“ Base B. F.....	39 43.2	76 20.1		70 27.6								
37B	“ Rd. St.....	39 43.2	76 20.1	8 43.4	70 20.9	19047	18827	2889	53338	56637			
37C	“ Ramsay's Field.....	39 43.2	76 21.0		71 01.2								
37D	“ Serp. Q.....	39 43.3	76 20.1		73 15.8								
37E	“ Slate Q.....	39 43.2	76 18.5		70 37.8								
37F	“ ¼ m. W.....	39 43.3	76 20.3		71 53.3								
37G	“ Whiteford Q.....	39 42.5	76 20.6		73 08.0								
37H	“ Flaherty Prop.....	39 43.0	76 20.0		71 14.9								
37I	“ Cambria.....	39 42.0	76 20.0		70 50.8								
37J	“ Sch. Hse.....	39 43.2	76 20.1	7 35.6	70 33.7	20090	19914	2655	56927	60268			
37K	“ Peerless Sl. Q.....	39 42.6	76 19.0	6 59.0	70 45.9	19831	19684	2411	56834	60195			
31	Ellicott City.....	39 16.2	76 48.2	4 53.9	70 33.4	20042	19969	1711	56775	60209			Howard
46	Woodstock.....	39 20.0	76 52.2		.....	19688							
85	Lisbon.....	39 20.1	77 04.1	4 43.7	71 22.7	19715	19648	1625	58509	61742			
57A	Chestertown, Col.....	39 12.9	76 04.0	5 54.8	70 37.1	20011	19904	2062	56883	60800			
58	Tolchester.....	39 12.9	76 14.3	5 44.9	70 47.5	19689	19590	1972	56512	59844			Kent
9	Massey.....	39 18.5	75 48.5	6 34.8	70 47.5	19751	19631	2263	56690	60033			
99	Betterton.....	39 21.9	76 03.9	4 05.5	71 17.6	19808	19259	1378	57022	60202			

TABLE XXI.—Continued.  
The magnetic elements and components in Maryland for January 1, 1900, arranged alphabetically according to county.

No.	STATION.	Position.		Mag'c Elements, Jan. 1, 1900.				Mag'c Components, Jan. 1, 1900.				County.	
		Lat. N.	Long. of Gr.	W. Decl'n. D.	Incl'n. I.	Hor. I. H.	North X.	West -Y.	Vert'l Z.	Total W.			
1	Linden, B. S.	39 00.5	77 03.1	0	70 41.9	3 38.0	70 41.9	19760	19721	1252	56421	59782	Mont- gomery
1A	" N. S.	39 00.7	77 03.1	3 48.3	70 26.3	3 48.3	70 26.3	19981	19937	1326	56233	59677	
42	Forest Glen.	39 00.8	77 03.2	3 46.3	70 24.4	3 46.3	70 24.4	19986	19943	1315	56149	59599	
67	Seneca.	39 04.8	77 20.6	2 38.2	70 51.7	2 38.2	70 51.7	19807	19786	877	57076	60414	
67A	"	39 04.8	77 20.6	2 32.7	70 51.6	2 32.7	70 51.6	.....	.....	.....	.....	.....	
62	Rockville	39 05.0	77 09.2	5 32.1	70 02.2	5 32.1	70 02.2	.....	.....	.....	.....	.....	
62A	"	39 05.0	77 09.2	5 44.7	.....	5 44.7	.....	.....	.....	.....	.....	.....	
108	Hunting Hill.	39 05.8	77 12.5	6 09.9	70 59.9	6 09.9	70 59.9	19851	19736	2132	57646	60968	
39	Stabler	39 07.2	76 59.1	.....	70 24.5	.....	70 24.5	.....	.....	.....	.....	.....	
107	Derwood	39 07.2	77 09.5	8 23.9	70 16.5	8 23.9	70 16.5	20376	20158	2976	56830	60373	
109	Quince Orchard.	39 07.2	77 15.4	4 16.5	70 58.5	4 16.5	70 58.5	19660	19605	1466	57015	60310	
84	Gaithersburg.	39 08.1	77 11.2	5 18.6	70 25.3	5 18.6	70 25.3	19911	19825	1845	55984	59418	
84A	" I.	39 08.2	77 12.5	5 44.0	70 43.0	5 44.0	70 43.0	19780	19681	1976	56537	59896	
84B	" II.	"	"	5 56.0	70 43.6	5 56.0	70 43.6	19720	19615	2038	56660	59994	
84C	" III.	"	"	5 28.2	70 47.5	5 28.2	70 47.5	19768	19678	1884	56740	60084	
84D	" Obs.	"	"	6 25.9	70 47.9	6 25.9	70 47.9	19798	19673	2217	56847	60196	
102	Waring	39 09.6	77 15.1	0 50.2	71 45.6	0 50.2	71 45.6	18803	18801	275	57056	60075	
103	Middlebrook	39 10.7	77 14.2	4 51.1	70 39.8	4 51.1	70 39.8	19825	19754	1677	56495	59873	
104	Cross Roads I.	39 11.4	77 11.6	6 04.4	70 04.4	6 04.4	70 04.4	20012	20012	2129	57452	60875	
105	Cross Roads II.	39 09.8	77 09.3	6 10.8	70 38.7	6 10.8	70 38.7	20177	20060	2172	57440	60881	
106	Redland	39 08.5	77 08.6	6 38.8	70 22.8	6 38.8	70 22.8	20086	19951	2325	56346	59818	
26	Dickerson.	39 13.5	77 25.2	.....	70 54.6	.....	70 54.6	19656	.....	.....	56796	60101	
26A	"	39 13.5	77 25.2	2 32.2	70 49.7	2 32.2	70 49.7	19660	19640	870	56547	59866	
40	Unity	39 13.7	77 03.5	5 43.4	70 32.9	5 43.4	70 32.9	20085	19934	2010	56308	59672	
41	Damascus.	39 17.4	77 12.5	4 12.2	70 45.7	4 12.2	70 45.7	19716	19663	1445	56495	59837	
4	Brandywine	38 41.7	76 50.8	.....	70 10.2	.....	70 10.2	.....	.....	.....	.....	.....	
110B	Cheltenham Obs	38 41.0	76 50.5	5 02.5	70 23.0	5 02.5	70 23.0	20189	20111	1774	56749	60234	
2	Marlboro	38 49.0	76 45.2	5 08.9	70 17.1	5 08.9	70 17.1	20197	20115	1812	56362	59872	
61	Laurel.	39 06.2	76 50.2	.....	70 41.0	.....	70 41.0	19827	.....	.....	56565	59339	

TABLE XXI.—Continued.  
The magnetic elements and components in Maryland for January 1, 1900, arranged alphabetically according to county.

No.	STATION.	Position.			Mag'c Elements, Jan. 1, 1900.			Mag'c Components, Jan. 1, 1900.				County.
		Lat. N.	Long. W. of Gr.	W. Decl'n. D.	Incl'n. I.	Hor. I. H.	North X.	West —Y.	Vert'l Z.	Total W.		
64	Kent I., S. B.	38 53.9	76 22.0	5 28.8	70 28.1	20132	20040	1923	56752	60217	Queen Anne's	
65	Stevensville.	38 58.8	76 18.8	6 01.3	70 27.9	19937	19995	2109	56191	59624		
8	Centerville.	39 02.5	76 03.7	6 01.3	70 27.6	20106	20765	1775	56853	60115	St. Mary	
6	Leonardtown.	38 17.4	76 38.1	4 53.1	69 31.9	20841	20342	1740	55335	59599		
5	Mechanicsville	38 26.6	76 44.7	4 53.3	69 42.5	20416	20642	1767	55217	58870	Somerset	
43	Crisfield	37 59.5	75 49.9	4 53.6	69 32.2	20718	20457	1874	55521	59261		
16	Princess Anne.	38 12.4	75 42.5	5 14.1	69 47.9	20543	20362	2029	55829	59488	Talbot	
59	Oxford	38 41.4	76 10.5	5 41.5	70 02.0	20463	20361	1969	56324	59025		
45	Tlghman Is.	38 42.9	76 20.0	5 31.5	70 00.4	20456	20183	2014	56222	59830	Wash- ington	
7A	Easton	38 46.0	76 04.4	5 41.9	70 12.0	20283	19837	1569	57201	60563		
68	Maryland Heights, S.	39 19.7	77 43.5	4 31.3	70 49.1	19899	19798	1510	56826	60196	Wicomico	
68A	" F.	39 20.4	77 43.0	4 21.7	70 44.4	19856	19579	1621	57023	60313		
22	Hagerstown	39 38.4	77 42.8	4 43.9	70 59.4	19646	19609	1582	56986	60289	Worcester	
22A	"	39 38.1	77 44.9	4 36.7	70 57.3	19673	19637	1558	57139	60439		
6	Hancock	39 41.6	78 10.3	4 32.2	70 58.7	19699	20338	1892	56063	59669	Worcester	
17A	Salisbury, M. L.	38 22.4	75 38.2	5 18.9	69 58.9	20426	20326	1973	56013	59620		
18	Parsonsburg	38 23.8	75 26.6	5 32.7	69 58.1	20422	20533	1926	55597	59298	Worcester	
15	Pocomoke City	38 04.8	75 33.8	5 21.6	69 38.9	20623	20583	1883	55622	59338		
14	Snow Hill	38 10.5	75 23.8	5 13.6	69 36.9	20669	20417	1997	56034	59672	Worcester	
13	Berlin	38 19.9	75 13.3	5 35.1	69 53.5	20515	20255	1994	55764	59361		
12	Ocean City	38 20.0	75 05.8	5 37.3	69 56.9	20353						

PRELIMINARY ATTEMPT AT AN ANALYSIS OF THE TERRESTRIAL MAGNETIC  
FIELD IN MARYLAND.

The first thing necessary is to determine the distribution of magnetism prevalent in Maryland if the local disturbing influences did not exist. This distribution we shall call the uniform or normal distribution and shall define it as that due to a potential  $V$  resulting from a homogeneous or uniform magnetization of Maryland. If  $u$  be the co-latitude and  $\lambda$  the longitude (counted positive to the east) of a station and  $u_n$ ,  $\lambda_n$ , the co-latitude and longitude, respectively, of the intersection of the magnetic axis of the uniform magnetic distribution with the Northern Hemisphere and  $c = \frac{4}{3} \pi \mu$ , in which  $u$  is the intensity of magnetization per unit of volume, then is:<sup>1</sup>

$$-V = c \cos u_n \cos u + c \sin u_n \sin u \cos (\lambda_n - \lambda), \quad \dots \quad (5)$$

$$X = c \cos u_n \sin u - c \sin u_n \cos u \cos (\lambda_n - \lambda), \quad \dots \quad (6)$$

$$Y = c \sin u_n \sin (\lambda_n - \lambda), \quad \dots \quad (7)$$

$$Z = 2c \cos u_n \cos u + 2c \sin u_n \sin u \cos (\lambda_n - \lambda). \quad \dots \quad (8)$$

It will be seen that we assume as our uniform field one that is physically interpretable, in which the normal components are not derived independently from empirical formulæ, as is frequently done, but instead all derivable from one function and thus referring to a common system of magnetic distribution.

The quantities to be operated with are the components  $X$ ,  $Y$ ,  $Z$ , given in Table XXI. Adapting equations (6), (7) and (8) to least square treatment, supposing  $c$ ,  $u_n$  and  $\lambda_n$  to be unknowns and putting  $x = c \cos u_n$ ,  $y = c \sin u_n \sin \lambda$  and  $z = c \sin u_n \cos \lambda_n$ , we obtain as conditional equations,

$$X = x \sin u - y \cos u \sin \lambda - z \cos u \cos \lambda, \quad \dots \quad (9)$$

$$Y = y \cos \lambda - z \sin \lambda, \quad \dots \quad (10)$$

$$Z = 2x \cos u + 2y \sin u \sin \lambda + 2z \sin u \cos \lambda. \quad \dots \quad (11)$$

As far as the final results are concerned, it is immaterial whether the normal equations are obtained from these equations in the form given or if both members of equation (11) be divided through by 2

<sup>1</sup> See Journal "Terrestrial Magnetism," Vol. iv, p. 40, and Vol. vi, p. 20.



before forming the normal equations. If the latter procedure be followed then the normal equations, supposing there are  $n$  stations, reduce to the following simple form:

$$nx = \sum_0^n (X \sin u + \frac{1}{2}Z \cos u), \dots \dots \dots (12)$$

$$ny = \sum_0^n (-X \cos u \sin \lambda + Y \cos \lambda + \frac{1}{2}Z \sin u \sin \lambda), \dots \dots (13)$$

$$nz = \sum_0^n (-X \cos u \cos \lambda - Y \sin \lambda + \frac{1}{2}Z \sin u \cos \lambda), \dots \dots (14)$$

From which  $x, y, z$  can be found and  $\tan \lambda_n = \frac{y}{z}, \tan u_n =$

$$\frac{\sqrt{y^2 + z^2}}{x} \text{ and } c = x \sec u_n. \dots \dots \dots (15)$$

In forming the normal equations it was thought best to give each component equal weight and not to assign a system of weights derivable merely from the error of observation, e. g. inversely as the square of the probable error; thus the  $Y$  component would obtain the greatest weight and the  $Z$  component the least weight, whereas in reality the  $Z$  component is the most effective one in the determination of the uniform distribution and the  $Y$  component the least effective.

The available values of  $X, Y, Z$ , as given in Table I, were combined into 16 groups so as to eliminate as far as possible local disturbances. The resulting normal equations were:

$$16x = 5.33585, \text{ hence } x = + 0.33349, \dots \dots (16)$$

$$16y = 1.52469, \text{ hence } y = + 0.09529, \dots \dots (17)$$

$$16z = 0.06576, \text{ hence } z = + 0.00411, \dots \dots (18)$$

Substituting these values in (15) we have

$$\lambda_n = 87^\circ 31'.8 \text{ W}, u_n = 15^\circ 57'.5 \text{ or } \varphi_n = 74^\circ 02'.5 \text{ and } c = 0.34686. (19)$$

With these values equations (6), (7) and (8), using the latitude instead of the co-latitude  $u$ , become:

$$X = [9.52308] \cos \varphi - [8.97940] \sin \varphi \cos (\lambda - 87^\circ 31'.8), (20)$$

$$-Y = \dots \dots [8.97940] \sin (\lambda - 87^\circ 31'.8), (21)$$

$$Z = [9.82411] \sin \varphi + [9.28043] \cos \varphi \cos (\lambda - 87^\circ 31'.8). (22)$$

The bracketed quantities are the logarithms of the coefficients.

With the aid of equations (20), (21) and (22) the uniform or normal or undisturbed magnetic components can be computed for any station of which the latitude and longitude are known. Computing them for the stations given in Table XXI and subtracting the computed or normal values of  $X$ ,  $Y$  and  $Z$  from those deduced from the observed magnetic elements, the residual magnetic components  $\Delta X$ ,  $\Delta Y$ ,  $\Delta Z$  are derived which represent the effect of the forces disturbing the uniform magnetic distribution. From the residual components the direction of the magnetic needle assumed, if the uniform field were eliminated or annulled and simply the local disturbing forces were operative, can be determined. Thus the magnetic declination due alone to the disturbing forces is given by the

equation  $\tan D_r = \frac{\Delta Y}{\Delta X}$ , the dip by  $\tan I_r = \frac{\Delta Z}{\sqrt{\Delta X^2 + \Delta Y^2}}$ , the horizontal intensity, by  $H_r = \sqrt{\Delta X^2 + \Delta Y^2}$  and the total intensity by  $W_r = \sqrt{\Delta X^2 + \Delta Y^2 + \Delta Z^2}$ .

A preliminary map showing the effect and the location of the disturbing forces has been constructed and a number of deductions of interest alike to the geologist and the magnetician have been drawn. Owing to pending additional investigations, the publication of the map will be deferred until it can be put in its final form.

In conclusion, I desire to make acknowledgment of the effective assistance rendered in the computations and in the construction of the charts by Messrs. J. A. Fleming and W. F. Wallis, both of the Coast and Geodetic Survey.

PART II.  
FINAL REPORT  
ON THE  
SURVEY OF THE BOUNDARY LINE  
BETWEEN  
ALLEGANY AND GARRETT COUNTIES,  
IN ACCORDANCE WITH AN ACT PASSED AT  
THE SESSION OF THE GENERAL ASSEMBLY OF 1898.  
(Laws of Maryland, 1898, Chapter 304.)  
BY  
L. A. BAUER, Chief of Party.

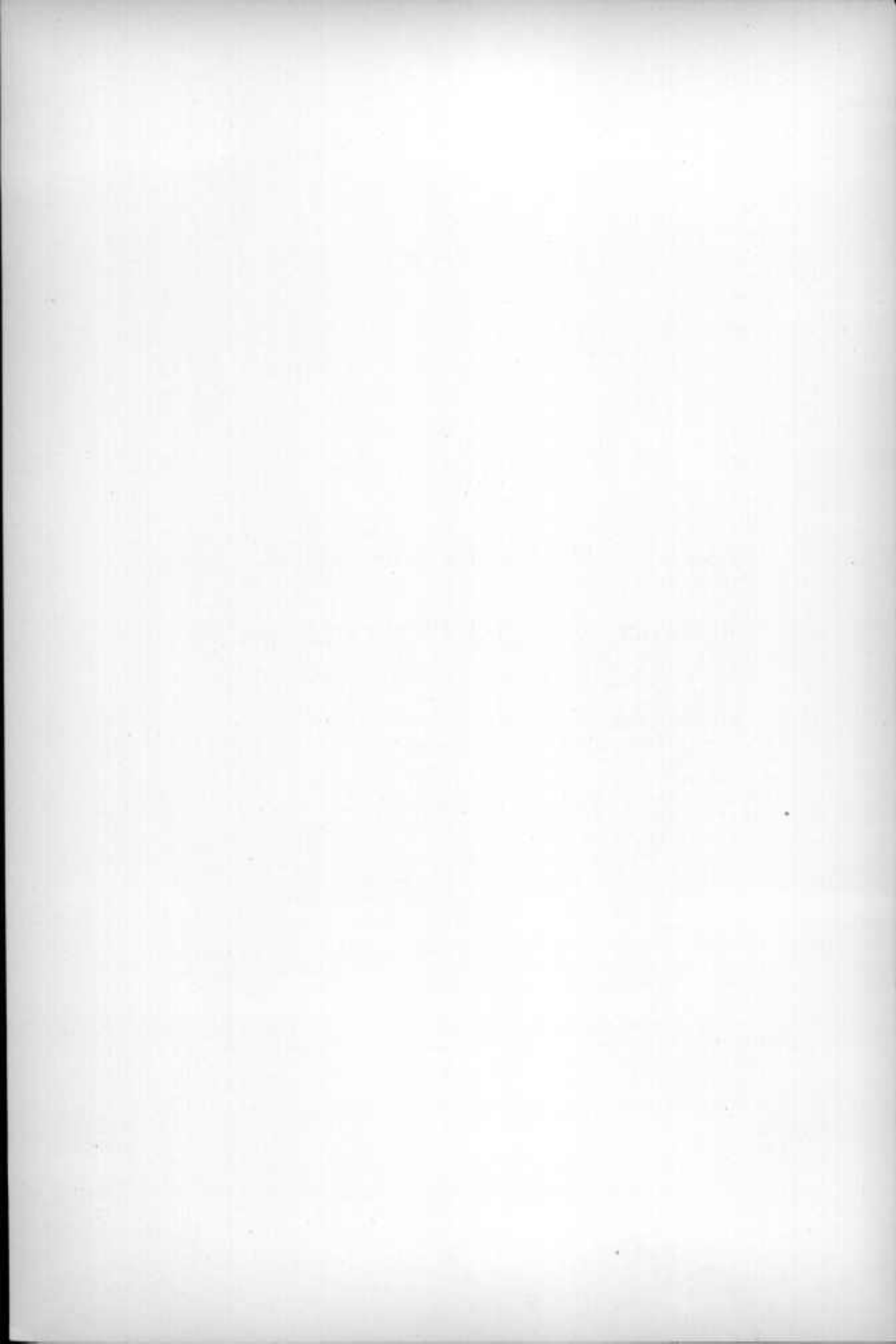

FINAL REPORT  
ON THE  
SURVEY OF THE BOUNDARY LINE BETWEEN  
ALLEGANY AND GARRETT COUNTIES,<sup>1</sup>

BY  
L. A. BAUER, Chief of Party.

---

INTRODUCTION.

A perusal of the following act passed by the Maryland Legislature at the January session, 1898, will explain the nature and purpose of this survey.

LAWS OF MARYLAND, 1898.

Chapter 304.

AN ACT to provide for the definite establishment and location of the boundary line between Allegany and Garrett counties, in order to bring under the assessment law certain untaxed lands in said counties. (January session, chapter 304.)

*Whereas*, By chapter 212 of the Acts of Assembly of 1872, provision was made for the formation and establishment of Garrett county out of the lands within the then corporate limits of Allegany county; and

*Whereas*, Provision was by said Act also made for a survey of the boundary lines of said counties, as established by said Act between certain terminal points therein named, and that return of said survey and the plats of said lines should be reported to and filed with the Governor, the County Commissioners and the clerk of the Circuit Court for Allegany county, under certain provisions in said Act contained, which provisions were complied with, but the said returns and plats have not been returned in compliance with the requirements; and

*Whereas*, By reason of said failure to make said return and file said plats, the boundary line between said counties is now an unsettled question, thus involving both questions of jurisdiction of courts and the rights of taxation; and,

*Whereas*, There are now large and valuable areas of land in both of said counties untaxed or unassessed, to the great loss and injury of said counties, as well as the state of Maryland; and

<sup>1</sup> A preliminary report was published by the Survey in September, 1898.

Whereas, It is to the interest of all of the taxpayers of said counties and the state of Maryland, that said boundary line should be definitely located, and thus increase the taxable areas of said counties; therefore

SECTION 1. *Be it enacted by the General Assembly of Maryland*, That immediately after the passage of this Act the Governor shall appoint or procure the services of a competent and skillful civil engineer or surveyor, who shall at once survey and definitely locate on the ground the boundary line between Allegany and Garrett counties, on line between terminal points established by chapter 212 of the Acts of 1872, which said civil engineer or surveyor shall employ, at his own cost, the necessary chainmen and axmen, or other necessary assistance, and procure the stones for marking the line as hereinafter provided; and for all said services of said engineer, and for his expenses for chainmen, axmen and other assistance, and for stones, plats and all materials used by him, he shall be paid a sum of money not exceeding one thousand dollars, one-half thereof by the County Commissioners of Allegany county and one-half thereof by the county commissioners of Garrett county; and said commissioners of said counties shall in their levies of taxes next occurring after the passage of this Act, levy the sum of five hundred dollars for each of said counties for the cost of said survey; and they shall pay said engineer such part of said amount as is necessary in full compensation for all his services, assistance, materials and expenses as aforesaid; and the Governor shall require said engineer to give bond with such sureties and in such sum as he shall deem proper conditioned to the faithful discharge of the trust reposed in him.

SEC. 2. Said engineer shall, as soon as he has surveyed and established the true division line, as aforesaid, permanently mark said line on the ground at its terminal points, and along said line by planting thereon and along the same suitable stones, properly marked, to designate said division line, so placed as not to be more than one mile apart along said whole line.

SEC. 3. *And be it enacted*, That immediately after the completion of said survey said engineer shall make a full and detailed report of said survey with the courses and distances of the same and a plat of the same, which report and plat shall be made in triplicate, and one each of the same shall be filed by him with the clerks of the Circuit Courts for Allegany and Garrett counties and one with the Commissioner of the Land Office, and be recorded by said officers in the record books of their said offices; and a copy of said report shall be also transmitted to the Governor, who, upon approval of the same, shall notify the County Commissioners of said counties, after which they shall make full payment to said engineer as aforesaid; but nothing in this Act shall be construed to prevent the County Commissioners of either or both of said counties from advancing to said engineer any part of his said compensation as they may see fit prior to said final payments, upon being satisfied from the progress of the survey that such engineer is entitled to such advance payments; and upon the approval of the Governor of the true made and established line by the surveyor, approved under this Act, the said line shall be and is hereby made the legal and established boundary line between Allegany and Garrett counties, between the terminal points as established by chapter 212, acts of 1872.

SEC. 4. *And be it further enacted*, That said boundary line shall be com-

pleted and permanently established within one year from the date of the passage of this Act.

SEC. 5. *And be it enacted*, That this Act shall take effect from the date of its passage.

Approved April 7, 1898.

LLOYD LOWNDES,

*Governor.*

J. WIRT RANDALL,

*President of the Senate.*

LOUIS SCHAEFER,

*Speaker of the House of Delegates.*

The original act referred to in the foregoing is as follows:

LAWS OF MARYLAND, 1872.

Chapter 212.

AN ACT to provide for taking the vote of the people for or against a new county in certain election districts in Allegany county at the election to be held in the fall of eighteen hundred and seventy-two.

SECTION 1. *Be it enacted by the General Assembly of Maryland*, That all that part of Allegany county lying south and west of a line beginning at the summit of Big Back Bone, or Savage Mountain, where that mountain is crossed by Mason's and Dixon's line, and running thence by a straight line to the middle of Savage River where it empties into the Potomac River; thence by a straight line to the nearest point or boundary of the State of West Virginia; then with the said boundary to the Fairfax Stone shall be a new county, to be called the county of Garrett; *provided* the provisions of this Act as to taking census of the people and the area of the said new county, and the sense of the people therein, shall be complied with in accordance with the Constitution of this State. . . .

SEC. 11. *And be it enacted*, That . . . and on application of five citizens of the proposed new county of Garrett, the County Surveyor of Allegany county shall at once run and locate the lines of the proposed new county of Garrett, at the expense of said petitioners, and shall make a plat of said lines and report the same to the Governor, the County Commissioners and the clerk of the Circuit Court for Allegany county, to be by him recorded in the land records of said county, said report to be made under oath.

The Governor, being empowered to appoint the civil engineer in charge and desiring that the work should be done in as thorough a manner as possible and in accordance with modern and approved methods, requested the Maryland Geological Survey, through its representative, Professor Wm. Bullock Clark, to undertake the survey of the desired boundary line. Professor Clark accepted the Governor's proposal and referred the execution of the work to my division.

It will be noticed that the act made no provision for the appointment of commissioners or surveyors representing the counties involved. This was a great oversight, and in order to rectify it, the State Geologist requested the following two surveyors to represent their respective counties and to render me any assistance in their power, viz.: Mr. W. McCulloh Brown of Garrett county and Mr. John Schaidt of Allegany county. Mr. Schaidt, finding that his private interests would not permit him to accept, recommended Mr. L. L. Beall, who accordingly was appointed as the surveyor representing Allegany county. The surveying party was finally composed as follows:

- L. A. Bauer, in charge.
- L. L. Beall, surveyor for Allegany county.
- W. McCulloh Brown, surveyor for Garrett county.
- C. A. Ashby, head lineman.
- J. M. Harris,
- J. L. A. Burrell,    { Assistants.
- G. P. Blackiston,  {

The necessary axmen and laborers were hired as occasion demanded.

The entire instrumental outfit, with the exception of the transits belonging to the surveyors, was furnished by the United States Coast and Geodetic Survey, viz.:

1. 8-inch position theodolite, reading with the aid of two opposite micrometer microscopes to 2" (by estimation to  $\frac{1}{2}$  of a second) and numbered "133."
2. 4-inch Fauth theodolite, No. 163. The horizontal limb could be read, with the aid of two small microscopes, to 20" and the vertical circle to 30".
3. Magnetometer No. 18 and attached theodolite.
4. Kew Dip Circle No. 56/4440.
5. Mean Time Chronometer, Dent, No. 2256.
6. Two heliotropes (Nos. 53 and 304).
7. 50-foot Steel Tape No. 86.

Besides these instruments, each surveyor had his own transit (the usual engineer's transit, horizontal circles reading by opposite ver-



niers to nearest half-minute). Mr. Brown furthermore provided two 100-foot steel tapes, one of which had been compared at the Coast and Geodetic Survey Office. The "standard" tape was never used for the field work, but was left at our headquarters and the second 100-foot tape was compared with it whenever necessary.

The special observing tent was the property of the Maryland Geological Survey, and is, in fact, the one used in the magnetic work.

The Maryland Geological Survey desires to make herewith grateful acknowledgment of the great service rendered by the Superintendent of the Coast and Geodetic Survey in providing it with such a valuable instrumental outfit.

Our thanks are also due to the Topographic Corps of the U. S. Geological Survey for promptly furnishing triangulation data and photographic copies of their topographic field sheets.

#### PREVIOUS ATTEMPTS AT A DETERMINATION OF THE BOUNDARY LINE.

##### CHISHOLM'S LINE.

The first line was run in 1872 by Mr. Dan Chisholm, at that time county surveyor for Allegany county. He used a compass, and, it is said, planted his tripod in the middle of the mouth of the Savage river—the southern terminal point of the line—and ran by the needle N. 26° E. In the absence of any returns from this survey, it is not now possible to say how Chisholm obtained this trial course—doubtless by plotting the line on the best map procurable at the time. From various statements made to me, it would appear that Chisholm did not run continuously on this course, but made various offsets. Instead of hitting the summit of the great Savage mountain, where it is crossed by the Mason and Dixon line, as called for by the act, he came out on the Little Savage mountain, 4307 feet, or  $\frac{4}{5}$  of a mile, to the west of the initial point called for by the act. Chisholm marked his line by blazes (a cross) in trees. In justice to him, it is stated that he regarded his line merely as a trial line, and that it was his intention to run a second and final line on a corrected course, an intention which was never carried out. This line is referred to by the people living in its vicinity as "the old line."

Whenever it was possible to do so, measurements were made from our line to the trees bearing Chisholm's blazes.

In view of the fact that Chisholm's line did not comply with the provisions of the act of 1872, viz., that the boundary should be a straight line connecting two given terminal points, one at the mouth of the Savage river and the other on top of the Great Savage mountain (not the Little Savage mountain where Chisholm's line terminated), it cannot be looked upon in any sense whatever as a boundary line actually run. Had Chisholm connected his last station with the point on the Great Savage mountain called for by law, it is quite probable that his line, as defined by the still existing blazed trees, no matter how crooked this line may be, would have to be accepted to-day as the boundary line. Chisholm, furthermore, made no official returns of his survey as called for by the act.

#### HARNED'S LINE.

The next attempt at a determination of the boundary line was made in 1878 by Mr. John Harned, county surveyor for Garrett county.

In this survey, Mr. John Schaidt, surveyor for Allegany county, was present. Harned used a compass mounted on a Jacob's staff, and began "at stone pile on summit of Savage mountain where crossed by Mason and Dixon line." The course he ran on brought him out at Westernport, considerably to the east of the terminal point, the mouth of the Savage river. It is stated that he ran a second line on a corrected course, but he did not mark it in a permanent manner, and, in fact, it is not possible at present to readily identify his line. He prepared a map of this line and filed it with the county commissioners of Garrett county, but his work was not adopted by either county. This map bears the following inscription:

"Garrett and Allegany county line Resurveyed for the Commissioners of Garrett in June, 1878; true bearing S. 28° 33' W., and whole distance 18 miles, 212 perches, differing from former survey 2° 33', and adding to the area of Garrett 4266 $\frac{1}{8}$  acres of land. Beginning at stone pile on summit of Savage mountain where crossed by Mason and Dixon line, then S. 28° 33' W. 18 miles, 212 perches to mouth of Savage river. 22nd day of June, 1878, by John Harned, surveyor for Garrett county."

The course referred to above (S. 28° 33' W.) is doubtless the magnetic course of the corrected line, not of the first or trial line.

From the preceding remarks it is evident that it was my duty, as defined by the act of 1898, to disregard all previous surveys and existing marks and determine the line anew in conformity with the provisions of the original act.

#### THE PROBLEM STATED.

The boundary line begins at a point on top of the Great Savage mountain, where that mountain is crossed by the dividing line between Maryland and Pennsylvania, and runs thence to the middle of the mouth of the Savage river, 18.6 miles distant, and across the Potomac river 121½ feet, to the nearest point of the West Virginia boundary. The main problem then is to connect by a straight line two non-intervisible points, one on top of a mountain, the other in the middle of a river, completely encircled by high hills. The direction of the line connecting the two points is not given. We cannot tell then on what course to run if we start out at the northern terminus, for example, and endeavor to run a perfectly straight line to the mouth of the Savage river. Supposing the terminals precisely fixed, the first problem, then, is to determine by some means the direction or bearing of the straight line connecting the two main points. There are three general methods for doing this if the two points are not intervivable:

1. By connecting the terminal points by triangulation.
2. By determining the latitudes and longitudes of the terminal points.
3. By running a trial line.

#### TRIAL LINE METHOD.

The third method might be the simplest one under certain circumstances. For example, if the region between the terminal points consisted largely of cleared land or bare hills, so that a trial line could be run through from one end to the other without a great deal of expense and without consuming too much time, it might be advan-

tageous to employ this method, especially if the direction of the line, as referred to the true meridian, is approximately known.<sup>1</sup>

For every minute of error in its bearing, the trial line would diverge in the present instance at the rate of nearly  $1\frac{1}{2}$  foot per mile, or, in the total distance,  $28\frac{1}{2}$  feet. If the trial line is out by 5 minutes,  $\frac{1}{3}$  of a quarter of a degree, then it will not hit the mouth of the Savage by 143 feet. A glance over the figures in the foot-note,<sup>1</sup> with the added statement that the actual direction of the line at the Mason and Dixon line, as found by us, is  $26^{\circ} 04.9'$  and  $25^{\circ} 59.1'$  at the mouth of the Savage, will give an idea of the error involved by adopting any one of the quantities given in the foot-note table. In the present case, as the region traversed is densely wooded and exceedingly hilly throughout, a trial line run on a random course would have been a matter of considerable expense. It would have necessitated as much cutting as the actual line required. Again, if the trial line is out considerably, the distances to various points along the line must be accurately known, so that the proper offsets can be made from them to the true line.

The foregoing remarks apply to running a trial line with a *transit*. To attempt to run a trial boundary line with a *compass* is so ridiculous that the matter would not be seriously discussed here had not the previous attempts been made in precisely this way. A trial line

<sup>1</sup>*Approximate True Bearing of Boundary Line as Obtained from Previous Work.*

Locality.	True bearing.	Authority.	How obtained.
Mouth of Savage,	N 26 33 E	Chisholm	With aid of following data: Chisholm's magnetic course in 1872 was N 26° E, and his line was 4307 feet west, of true line at Mason and Dixon line.
"	N 26 06 E		Scaled from the U. S. Geological preliminary topographical map of region north of Mouth of Savage.
Mason and Dixon Line,	S 25 49 W	Harned	Harned says his magnetic course in June, 1878, was S 28° 33' W.
"	S 25 52 W		Scaled from U. S. Geological Survey topographical map (Frostburg sheet, 1898).
Mean	26 02.5		Referring to middle point of line.

should be as nearly straight as possible. *It is a physical impossibility to run a straight line with the magnetic needle under the most favorable circumstances.* These favorable circumstances would imply extraordinary facilities, such, for example, as the establishment and maintenance of a magnetic observatory, with the aid of which the manifold fluctuations of the magnetic needle could be duly allowed for while tracing out the trial line. The whole matter would be so expensive and so cumbersome that this method would be summarily abandoned. The surveyor is not accompanied by these favorable circumstances. He runs his lines regardless of diurnal variation, of magnetic storms, or even of geographical variation of the deviation of the compass from the true north. The diurnal variation alone may throw him out on a summer's day 15-20 feet in a mile. A magnetic storm may produce an error of the same magnitude and even greater. From a table given later, it will be seen that the magnetic bearing of the boundary line changes by nearly  $\frac{1}{2}^{\circ}$  from one end to the other. This alone would throw a magnetic trial line out, even if it were started correctly, by  $\frac{1}{8}$  of a mile at the other end. The surveyor very rarely determines the magnetic declination himself, and so the precise change from point to point on the line he either would not make at all (as being of too trifling a nature) or he would guess at it. Then, in addition, come the troublesome local variations. Thus, at the mouth of the Savage river, where Chisholm began, the needle is thrown out by  $\frac{2}{3}$  of a degree, or at the rate of about 60 feet per mile.

It will thus be seen that a line run by the "point of the needle" is one upon the correctness of which no reliance could or should be put.

#### LATITUDE AND LONGITUDE METHOD.

The second method, that of determining the latitudes and longitudes of the terminal points, would be one wholly out of the reach of the ordinary surveyor. To determine the true bearing of the boundary line by this method would require most superior astronomical instruments, expert observers, the adoption of very accurate methods,

and an expenditure of time of at least a month. And then this elaborate method would not furnish the direction of the line, in the present case, closer than to within 2 to 4 minutes. In other words, the line determined thus might easily be out 60 feet and more at its terminal point. In the present case, as the line had to be traced almost entirely from one thickly wooded hilltop to the other, and could not be sighted through, two cuttings would have been required—one for the first line and another for the corrected line. We may therefore dismiss this method as not practical in the present instance.

#### TRIANGULATION METHOD.

We thus come as a final resort to the triangulation method. This is one that the surveyor, provided with a good engineer's transit, if he knows how to use his instrument so as to get the full benefit of its various adjustments, can safely and advantageously employ.

After making a brief reconnaissance of the line, I quickly came to the conclusion that the triangulation method was the only practicable one in this case and at the same time the most expeditious.

There were several triangulation points in the vicinity of the line, established by the U. S. Geological Survey. (See Fig. 7.) I concluded, therefore, that the best method would be to connect the terminal points with each other and with the U. S. Geological Survey triangulation points by a series of triangles.

My original intention was to measure all the angles with the aid of the 8-inch theodolite, which, as stated, reads with the aid of microscope microscopes to 2", and, by estimation, can be read to  $\frac{1}{5}$  of a second. It was, however, a great task to transport this cumbersome instrument from hilltop to hilltop. The roads were at times exceedingly rough and steep. After reaching the top, the instrument would usually have to be carried a considerable distance, in some cases nearly a mile, and over rough rocks and through thick undergrowth. The instrument in its case weighs about 100 pounds. As the funds were rapidly ebbing and time was slipping away at a continually accelerating rate, I was compelled to give up this idea and depend in a large measure upon the smaller instruments—the surveyors' instru-

ments and my four-inch theodolite. A rough calculation convinced me that with proper care, the direction of the boundary line could be obtained in this way to within one minute and less in a comparatively short time and at little expense. To have gotten the direction so close as not to require any corrections would have made necessary the expenditure of considerable more time on the triangulation. This our limited appropriation would not permit. And I considered that

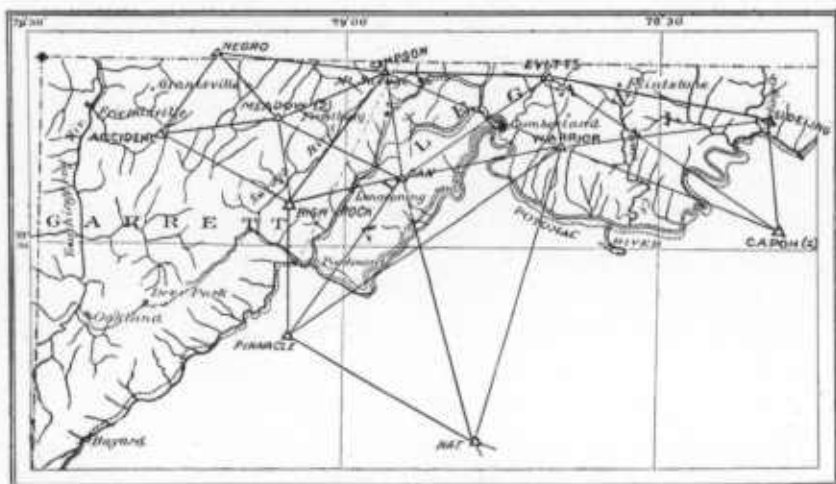

FIG. 7.—Showing the triangulation stations of the U. S. Geological Survey in the vicinity of the boundary line between Allegany and Garrett Counties. Scale: 1 inch = 16 miles.

a trial line correct within 1' was close enough for the purpose at hand. I therefore pushed the triangulation ahead to the utmost, so that the ranging out of the line could be begun and the proper corrections made, and, if possible, the line marked, before the appropriation ran out. And there was every danger of the funds running short, for we encountered most unfavorable weather. For three weeks we had rains almost every day, only three or four days in that time being absolutely clear.

#### A "STRAIGHT" LINE ON THE EARTH'S SURFACE.

Another point deserves elucidation in this connection. The law calls for a "straight" line connecting two points, whose position on the earth's surface is approximately:

	Latitude.	Longitude west of Greenwich.
Top of Big Savage mountain,	39° 43'.4	78° 54'.8
Mouth of Savage river,	39 28.8	79 04.0

Between these two points the rotundity of the earth makes itself appreciably felt. If we define a straight line in the customary manner, viz., as the arc of a great circle passing through the two given points, then the bearing of that line will be different at every point in that line. The difference in the bearings of the line at the two end points amounts to the difference of longitude into the sine of the average latitude of the two points, or to 5' 51" or 5'.85. So that if the true bearing of the line were S. 26° 04'.9 W. at the top of Savage mountain, it would be 5'.85 less at the mouth of the Savage river, or N. 25° 59'.1 E.

In other words, suppose a surveyor, provided with a good transit, were to begin at the mouth of the Savage river and run a line on the true course of the line at the upper end, viz. N. 26° 04'.7 E., then he would strike 50 yards to the west of the terminal point on the Mason and Dixon line. Two surveyors, one beginning at one end and the other at the other end, would therefore not meet each other unless they started their line, not on precisely the same courses, but on courses differing nearly 6 minutes, or 1/10 of a degree from each other. It is thus seen that the sphericity of the earth between the terminal points is a factor which must be duly considered in this problem.

That the bearing of the line, as referred to the true meridian, should vary continuously from one end to the other, can easily be seen thus: The two end points are not situated in the same true north and south line, but lie in different meridians, or, roughly, the mouth of the Savage is 8 miles west of the top of Savage mountain. As the meridians, if prolonged northward, all pass through the same point on the earth's surface—the North Pole—and are therefore not strictly parallel lines, but converge so that the distance apart between the two meridians passing through the end points of the line is about 50 yards less at the Mason and Dixon line than along a due east and west line passing through the mouth of the Savage river, hence the angle made by a line cutting the two meridians is less at the southern than at the northern point, as can be readily seen by drawing a diagram. (See Fig. 8.)

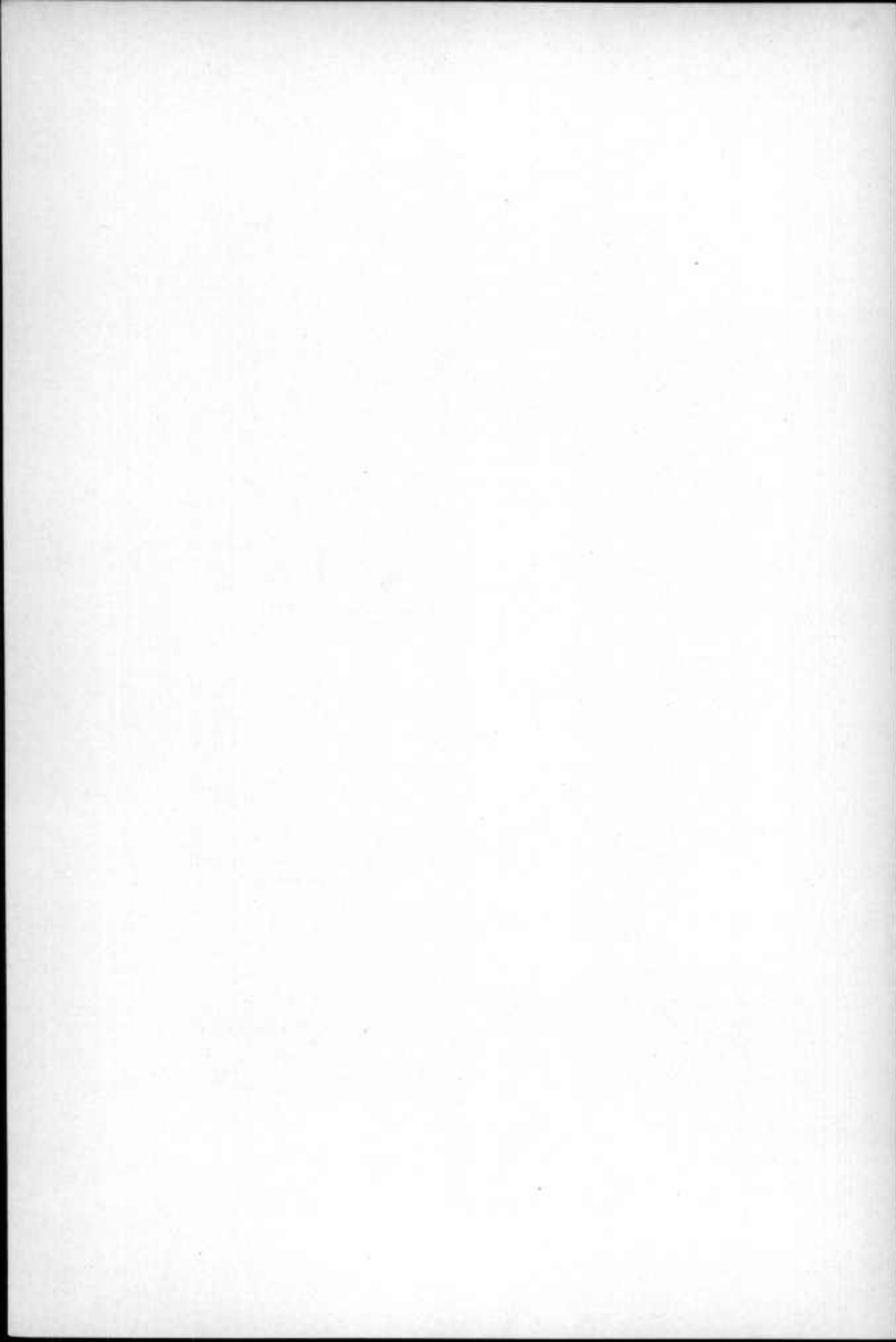



FIG. 1.—MOUND ON MASON AND DIXON LINE.



FIG. 2.—MOUND ON NATIONAL ROAD.



The magnetic bearing of the line, *i. e.* the angle made by the line with the direction pointed by the north end of the compass needle, varies even more than the true bearing. The total change from one end of the line to the other amounts to nearly  $\frac{1}{2}$  of a degree. See table giving courses and distances.

It is quite possible to have traced such a line passing through the given points so that the angle it made with the true meridian would be the same all along. Such a line is known as a "rhumb" line and would not be a straight line, but a curved one, *i. e.* it would not be a line that the surveyor could prolong indefinitely by backsighting and foresighting. He would have to make offsets in order to get back into the "rhumb" line. As, for example, he must do if he endeavors to prolong a due east and west line such as the Mason and Dixon line. This line is not a "straight" one, but a continuously curving one. The "rhumb" line as a boundary line should be avoided whenever possible.

Fig. 8 will give some idea as to the course of a line connecting the terminal points in such a manner so that:

1. The true bearing, *i. e.* the angle between the true meridian and the boundary line, shall be the same at every point in the line (true rhumb line).
2. The magnetic bearing, *i. e.* the angle between the magnetic

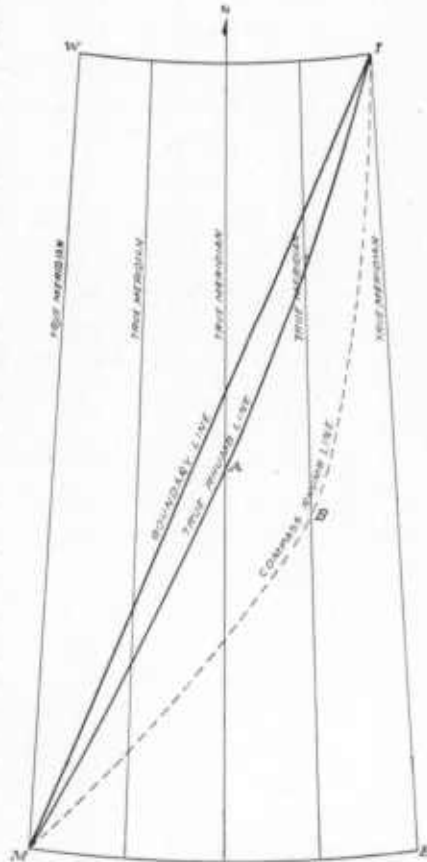

FIG. 8.—Diagram showing effect of convergence of true and of magnetic meridians.

meridian (direction pointed out by compass needle) and the boundary line shall be everywhere the same (magnetic rhumb line).

Both lines, it will be noticed, are curved, the second one much more than the first, as the magnetic meridians converge much more rapidly than the true meridians. The second line would in reality not be as smooth a curve as shown, but would be a very sinuous one on account of the many fluctuations to which the magnetic needle is subject. The magnetic or compass rhumb line would, furthermore, vary its nature somewhat with lapse of time by reason of the secular variation of the magnetic needle.

Now that the boundary line has been traced and permanently marked, the surveyor need no longer take into account the variation in the bearing of the line, if he will get the direction by sighting on one of our established mounds. He can establish any number of intermediate points by simply backsighting and foresighting. Should he be obliged, however, to know the bearing of the line (true or magnetic), he must make use of the table given later on.

#### THE TRIANGULATION.

Let us suppose for the moment that the terminal points have been precisely fixed. It is desired to connect these two points (*I* and *M*<sub>1</sub> in the sketch, Fig. 9) by a series of triangles. Some idea of the roughness of the country can be obtained from the map, Plate VII, and the profile of the line, Fig. 10.

Several hills and mountains were climbed in West Virginia by my head lineman, Ashby, and myself before a suitable point was found, from the top of which the mouth of the Savage river was visible, and also points in Maryland forward along the line and situated on opposite sides of it. This point is in an oatfield on the hill between Piedmont and Bloomington, on property owned by Thos. Davis and farmed by Mr. Daniels. From this point I could look right down into the mouth of the Savage river 1.4 miles away, and could also see High Rock (U. S. Geological Survey triangulation station), 6 miles distant, and establish a point on the high hill east of Pekin in a cornfield on the Jackson property farmed by Mr. Shimer. This point *J* was about  $6\frac{1}{2}$  miles away. It will be seen that the triangle formed by the three stations, "Daniels," "High Rock" and "Jackson" is a

FIG. 9.  
 —  
 TRIANGULATION  
 CONNECTING  
 TERMINAL POINTS  
 OF  
 BOUNDARY LINE.

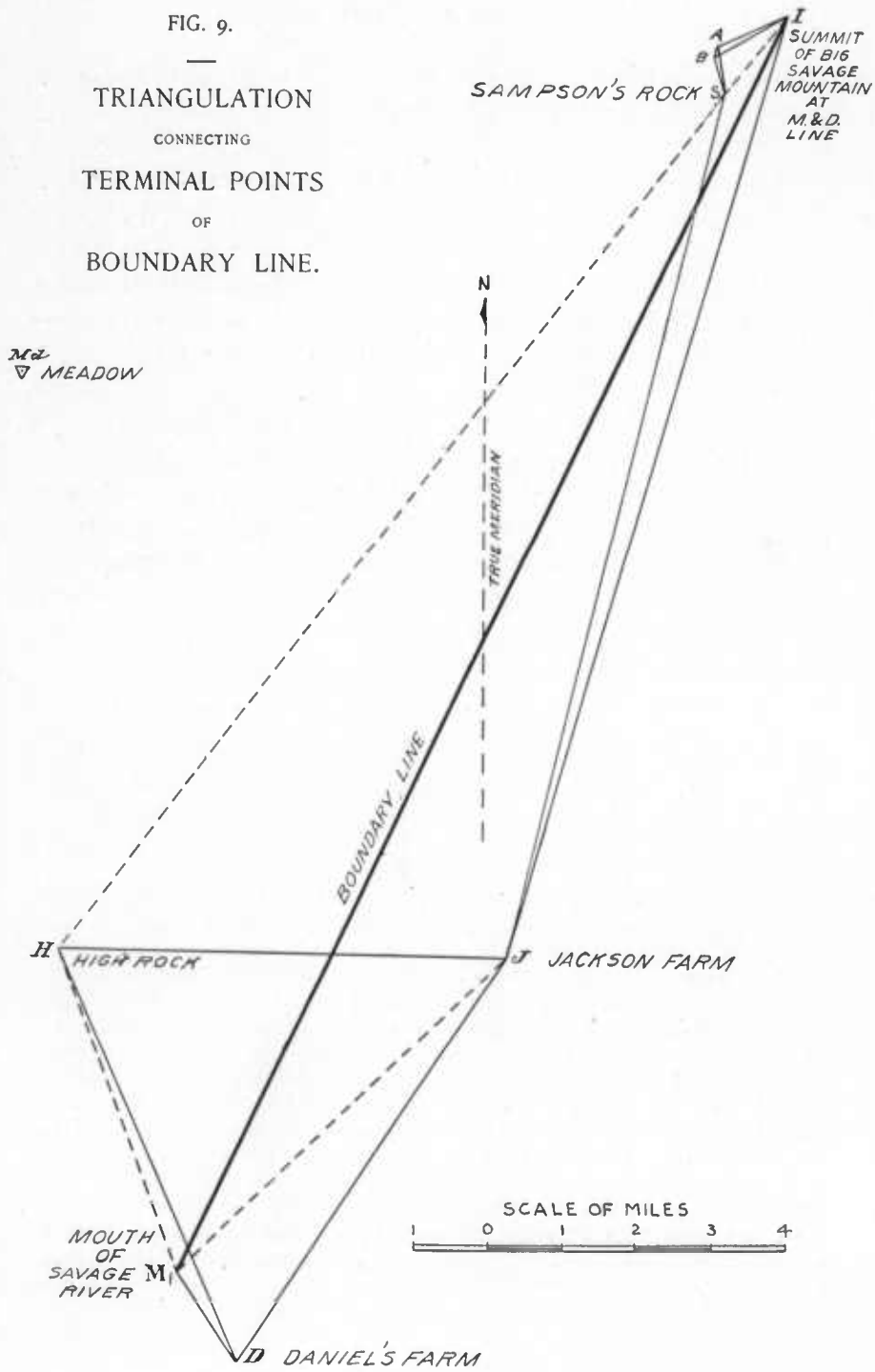

very good one, being almost equilateral. The angles were measured at *D* with the 8-inch theodolite by sighting upon poles placed at *M*<sub>1</sub>, *H* and *J*.

The 8-inch theodolite and tent were next moved to "Jackson," and it was found that from this point could be seen the U. S. Geological Survey triangulation stations, "High Rock" and "Sampson," and also with a little cutting the initial point of the boundary line on the top of Savage mountain. "High Rock" was 6 miles away, "Sampson" nearly 12 miles and "Initial" 13 miles. At "High Rock" and "Daniels" were poles, and from "Sampson" and "Initial" small mirrors were flashed. Mr. Ashby found that at "Sampson" considerable cutting would be required before the station at the ground could be made visible to me stationed at "Jackson." He therefore climbed to the top of the tripod left at this point by the U. S. Geological Survey, centered himself precisely with the plumb-bob over the bolt in the rock marking the precise station, and then held a 4 x 4-inch mirror in the proper direction, so that the sun striking it would be reflected toward me. By prearrangement, Mr. Brown, located at "Initial Point," not having a heliotrope at hand, flashed a small mirror at the same time at Mr. Ashby at "Sampson." Since one minute would correspond to a distance of about 20 feet at *S* and *I*, the method employed to make *S* and *I* visible was amply sufficient for the purpose.<sup>1</sup>

<sup>1</sup>By employing this simple device the surveyor can very often get very long sights. No special heliotrope is needed. His rodman should be provided with a mirror which he can easily put in his pocket, say 4 x 4 inches. If his station is so far away as to make sighting on a pole difficult, or should he wish to make sure that the pole he is sighting upon is the right one, let the rodman plant a stick about 5 feet high as nearly in line as he can with the eye and about 15 yards away from him. Now, if the sun is shining the rodman can place himself over the station point and hold the mirror in such a position that the reflected sun-ray will strike the stick planted 15 yards away. It is well for him to turn the mirror up and down, so that the reflected sun-ray will travel up along the stick and pass beyond it, and to keep on doing this until operations have been completed. In the same way the rodman can be put in line many miles away, if the surveyor likewise provides himself with a mirror and sends the rodman signal flashes according to a prearranged code. For signalling, a somewhat larger mirror than the rodman's will in general be found better. Of course a heliotrope is the best of all, but it is not always convenient to carry one.

When both mirrors showed up at the same time it was an hour's work to measure the angles in three different positions of the circle with the desired degree of accuracy. The mouth of the Savage was not visible from "Jackson," and so the line is broken. For the same reason we find the lines connecting *H*, *S* and *I* broken. These were "blind" lines in the triangulation scheme, *i. e.* the end points were not intervisible.

As only the distance *HS*, as determined by the U. S. Geological Survey, was known, it was necessary to measure some additional angles and to determine the distances *MD* and *SI* by measuring small bases and connecting the ends of the bases with the main triangulation, by secondary triangulations, before the angle, which the boundary line would make with *J*, for example, could be computed. The base measurements and secondary triangulations were undertaken by the two surveyors and their work will be detailed below.

The triangle *HDJ* was closed at *H* with my small 4-inch theodolite, measuring the angle by method of repetitions, and the angle *SHJ* was obtained. As *S* and *H* are not intervisible, it was necessary to measure the angle *MdHJ*, *i. e.* the angle between the U. S. Geological Survey triangulation station, "Meadow," and my station, "Jackson." Computing now the angle *MdHS* with the aid of preliminary data<sup>1</sup> furnished by the U. S. Geological Survey, the angle *SHJ* was finally determined.

<sup>1</sup>*Final Geodetic Co-ordinates of Certain Primary Triangulation Stations of the U. S. Geological Survey, in the Neighborhood of the Allegany-Garrett Boundary Line.*

Station.	Latitude.			Longitude.			Azimuth.			Logarithm Distance Meters.	To Station.
	°	'	''	°	'	''	°	'	''		
Dan.....	39	34	54.54	78	53	51.47	168	55	52	4.1547327	To Sampson.
							76	29	58	4.2463642	" High Rock.
							114	23	15	4.2921955	" Meadow (2).
Sampson....	39	42	28.94	78	55	46.56	289	54	51	4.4505251	" Warrior.
							68	34	20	4.2102258	" Meadow (2).
Evitts.....	39	42	49.36	78	39	53.38	88	29	46	4.3562999	" Sampson.
Meadow (2)..	39	39	16.25	79	06	20.15	294	15	18	4.2921955	" Dan.
							248	27	36	4.2102258	" Sampson.
							356	34	46	4.0873862	" High Rock.
High Rock...	39	32	40.43	79	05	49.59	256	22	20	4.2463642	" Dan.
							176	35	05	4.0873862	" Meadow (2).
Pinnacle....	39	22	55.53	79	04	44.04					

These final co-ordinates were furnished in December, 1898, and hence were not at my disposal until after the completion of the line and the publication of the preliminary report in September, 1898.

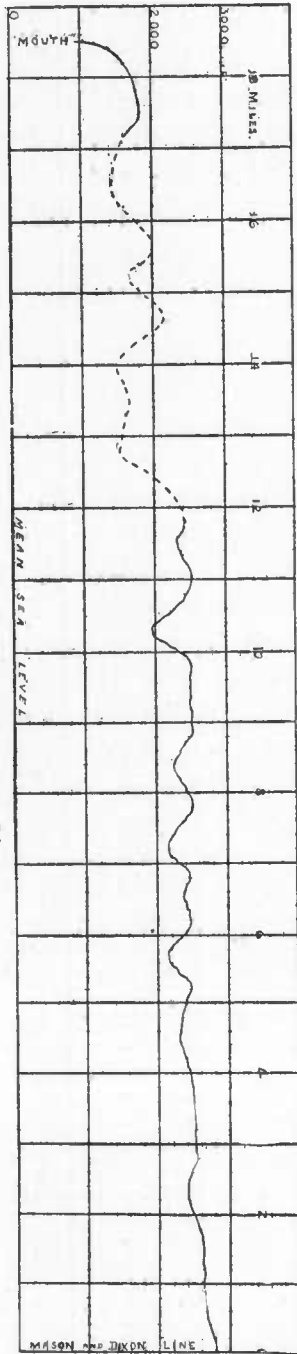

Fig. 10.—Profile of Boundary Line.

In precisely the same manner Mr. Brown, using his engineer's transit and the method of repetitions, obtained the angle  $HSJ$ , this angle closing the triangle  $HSJ$ .

It was most desirable also to close the triangle  $JSI$ . For this purpose the large theodolite and tent were transported to the top of the Savage mountain,  $I$ , and were left there until the line had been ranged out and marked. Messrs. Brown and Burrell measured a small base, 675.41 feet in length, on McKenzie's farm ( $AB$  in the sketch, Fig. 9). Mr. Brown used his 100-foot tape, the correction upon the standard tape being known and temperature correction being allowed for. From  $A$  and  $B$ ,  $S$  and  $I$  were visible, and the various angles were measured by Messrs. Beall and Brown independently of each other, each using his own engineer's transit, and measuring the angles in three different positions of the circle. The small angle  $AIB$  was measured with my 8-inch theodolite; the angle  $BSA$  was measured by Mr. Brown with his transit, employing the method of repetitions. The only angles in the quadrilateral  $IABS$  which could not be measured were  $BIS$  and  $ASI$ —this because  $S$  and  $I$  could not easily be made intervisible, a high ridge intervening. But these angles could be computed with the aid of the angles measured and knowing the



length of  $BA$ . Hence the angles  $BIS$  and  $ASI$  or  $BSI$  and  $AIS$  were known. When Mr. Brown had measured the angle  $BSJ$  with his instrument by method of repetitions and I had measured the angle  $JIA$  with my 8-inch theodolite, the triangle  $JSI$  had been closed. In order to be able to sight on "Jackson" (13 miles away) whenever occasion demanded, Mr. Harris was stationed at "Jackson" with one of the Coast and Geodetic Survey heliottes. He also put up a white screen back of the pole erected at this point, so that when the heliotope was not in use the pole could be sighted.

It only remained to know the horizontal distance from "Daniels" to "Mouth,"  $M_1D$ . This was obtained in the manner shown by the sketch of the secondary triangulation given below (Fig. 11.) The pole  $W$  was planted on hill back of Warnick's house in Bloomington, and the angle  $M_1DW$  was measured when the large instrument was stationed at "Daniels." The remaining angles in the triangle  $M_1DW$  were measured by Messrs. Beall and

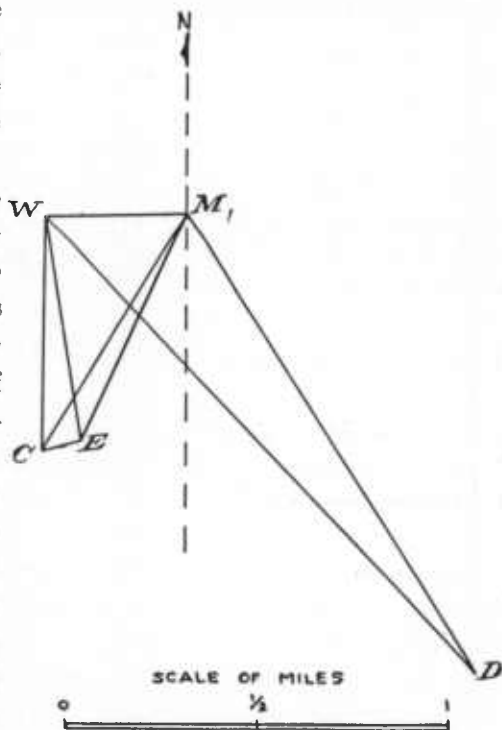

FIG. 11.—Secondary triangulation at the mouth of Savage River for the determination of the Distance from "Mouth" to "Daniels."

Brown independently of each other and in three positions of the circle. If now  $M_1W$  (about  $\frac{2}{3}$  of a mile) were known, then  $M_1D$  could be computed. To obtain  $M_1W$  the two surveyors carefully measured the small base  $EC$  at the foot of Hampshire hill in West Virginia and measured all the angles at the four points,  $M_1, E, C, W$ , in the manner already detailed. The length of the base with cor-

rections applied was 529.92 feet, and the distance  $M_1D$  was 7421.35 feet, the probable error being about 1 foot.

It was now possible to compute the angle which the boundary line made with one of the triangulation points, as, for example, the angle  $M_1IJ$ . Starting with the distance  $HS$ , as given by the U. S. Geological Survey data, it was possible to solve all the triangles without knowing the distance  $SI$ , which had been obtained by us with the aid of the McKenzie base,  $AB$ . The resulting angle  $M_1IJ$  was found to be:

$$9^\circ 22' 37'' \quad \text{I}$$

Since the length of  $SI$ , however, as obtained from  $HS$  differed from that derived by us by the small base measurement much more than it should, indicating that  $HS$  was not known with sufficient accuracy for our purpose,<sup>1</sup> I computed the angle  $M_1IJ$  again, this time starting with our distance  $SI$  and supposing  $HS$  not known. The angle obtained thus was:

$$9^\circ 22' 06'' \quad \text{II}$$

Had we not been pushed for time, I should have checked this angle further by determining the distance  $DJ$ . For this purpose, as I ascertained later, a base from which  $D$  and  $J$  would be visible could have been measured on Caledonia hill, back of Barton. It was then too late to carry out this idea. I therefore gave double weight to II and adopted for the angle  $M_1IJ$ :

$$9^\circ 22' 16'' \quad \text{III}$$

and ranged out a trial line. I felt sure that his line would be correct certainly to within one minute. As will be seen later, this surmise was found to be true.<sup>2</sup>

#### TRACING THE TRIAL LINE.

The longest sight that could be obtained was gotten with the 8-inch theodolite from Station  $I$ , on the top of the Savage mountain, to the

<sup>1</sup> Mr. Wilson, geographer of the U. S. Geological Survey, informs me that a much superior connection of their triangulation points with those of the Coast and Geodetic Survey has been recently made, which will necessarily improve their distances when the office computations have been made. [Sept., 1898.]

<sup>2</sup> With the aid of the revised co-ordinates, p. 117, I now get for the first angle,  $9^\circ 22' 19''$ . [Aug. 29, 1899.]



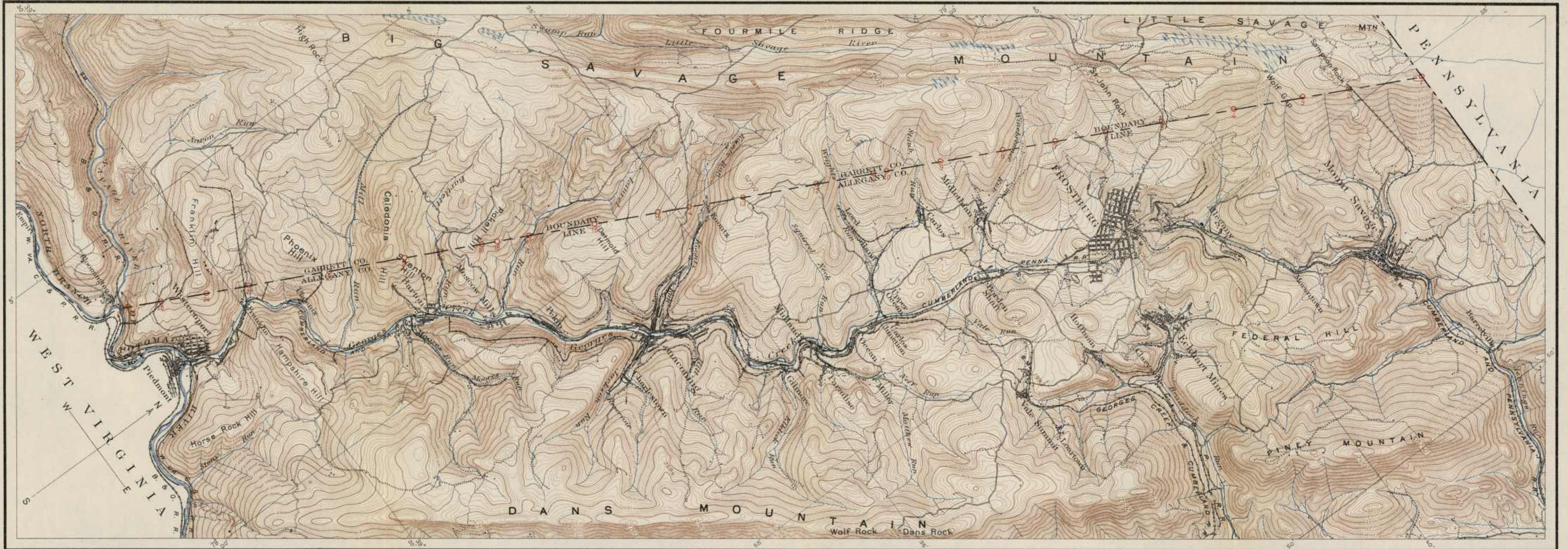

Engineers:  
 L. A. Bauer, in charge  
 L. L. Beall, Surveyor for Allegany County  
 W. M. Brown, Surveyor for Garrett County

MAP OF THE BOUNDARY LINE BETWEEN ALLEGANY AND GARRETT COUNTIES

IN ACCORDANCE WITH AN ACT PASSED BY THE GENERAL ASSEMBLY OF 1898 (LAWS OF MARYLAND 1898, CHAPTER, 304).

MARYLAND GEOLOGICAL SURVEY

WM. BULLOCK CLARK, STATE GEOLOGIST

Note: The location of the Boundary Monuments is shown by small red rings.

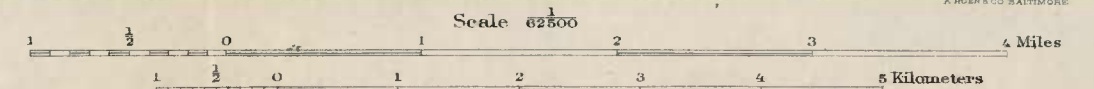

Contour interval 20 feet.

Datum is mean sea level.

D. 120 B



top of the hill west of Carlos,  $7\frac{3}{4}$  miles distant. To Mr. Brown, assisted by Mr. Finzel, was assigned the establishment of intermediate points between Carlos and the Initial Point. Messrs. Beall and Ashby undertook the tracing of the line southward from Carlos, and I, assisted by Mr. Harris, began at the mouth of the Savage and ran northward.

Mr. Beall's portion of the line was the heaviest one. The line invariably struck in the roughest portion of the numerous hills encountered and always at about the same level, so that the line had to be cut clear through. He had to set up his instrument 9 times before he succeeded in tracing the trial line through from Carlos to Franklin hill,  $9\frac{3}{4}$  miles away.

Not knowing how the trial line would come out, it was very essential that I should meet Mr. Beall as far from the mouth of the Savage river as possible. The top of the high hill directly north of the Savage river—Franklin hill—was thickly wooded, and if the trial line should be out by 1 minute, the cutting on Franklin hill, as made from the north, would be out by about 25 feet.

The easiest way of getting over Franklin hill was to prolong the line somewhat over a mile into West Virginia to a point high enough up on Hampshire hill that the line could be run forward from this point to the highest point of Franklin hill reached by the line. For this purpose the angle  $IM_1D$ —the angle which the line to "Daniels" made at the "mouth" with the boundary line—was computed and laid off and the boundary line was prolonged into West Virginia and then forward again across Franklin hill and to the north end of it.

When I reached the point thus established at the north end of Franklin hill, about  $1\frac{1}{4}$  mile from the mouth, I found that I could sight north along the line as far as the cutting on hill west of Lonaconing, somewhat over six miles away. Mr. Beall was seen putting Mr. Ashby on Caledonia hill, 3 miles north of me, in line with the aid of sun-flash signals. The supreme moment had come—the line had been sighted through! On the next day Messrs. Beall and Brown prolonged the trial line from Caledonia hill to my point on Franklin hill. Mr. Brown measured the distance between the two

points—the one obtained from the northward and the other from the south—and found that the former was 20.84 feet west of the latter. This was taken as the total error of the trial line. It represented the error in the bearing of the trial line, plus the error made in the running of the line.

Taking everything into consideration, I believe that this must be regarded as very satisfactory. This error was uniformly distributed along the line, the correction amounting to  $20.84 \div 18.6 = 1.12$  foot per mile. As the correction was so small, it was not necessary to know the distances between the established mounds very accurately, the nearest  $\frac{1}{16}$  of a mile amply sufficing. The correction was to the *west* from the “Mouth” to my hub on north end of Franklin hill and thereafter to the *east*.<sup>1</sup>

#### THE TERMINAL POINTS.

The first problem really was to determine these precisely and to mark them as permanently as possible, so that they might be readily reecovered at any future time. This had not been done by our predecessors.

The boundary, as stated, consists of two straight lines, one 18.6 miles long and the other 121½ feet in length. The first line begins “at the summit of Big Back Bone or Savage mountain, where that mountain is crossed by Mason’s and Dixon’s line.” This point I have called the “Initial Point” and have designated it by the letter *I*; and this part of the boundary line was to end at the “middle of Savage river where it empties into the Potomac river.” This point I have referred to as “Mouth” or *M*. The second straight line begins at the “Mouth” and proceeds to the “nearest point or boundary of the state of West Virginia.” This latter point is, therefore, the “Terminal Point,” *T*, of the entire boundary line. (See Fig. 12.)

The determination of these points was done largely by the two surveyors, Messrs. Beall and Brown. The terminal points having been agreed upon by the representatives of the two counties involved,

<sup>1</sup> As I ran north, while Mr. Beall ran south, the errors we committed, due to erroneous bearing of trial line, would be in the opposite direction.

it was my duty to connect their points in the simplest manner possible by straight lines.

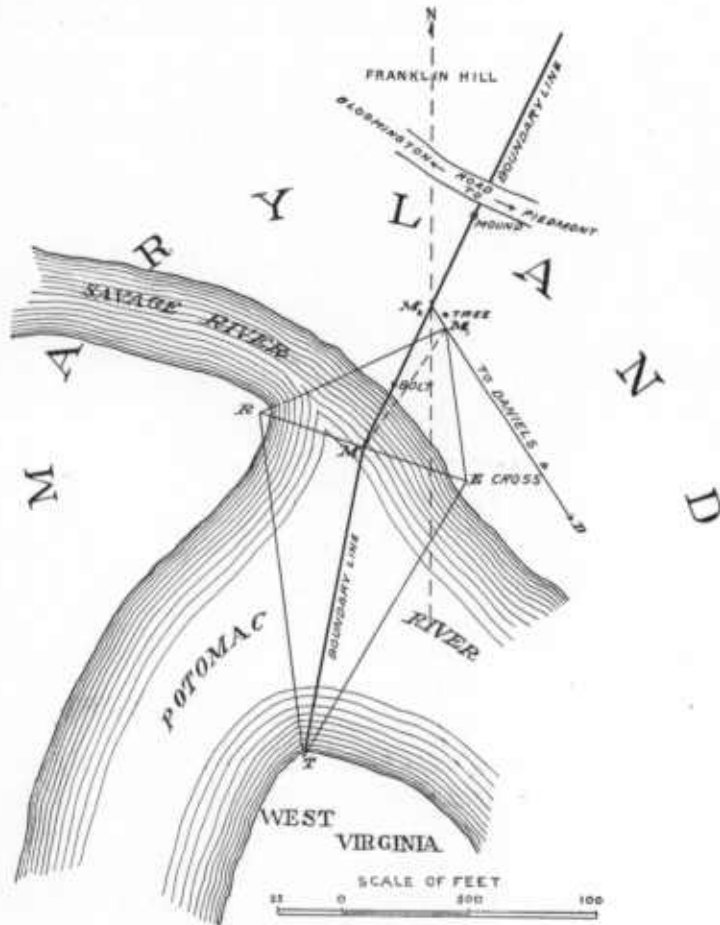

FIG. 12.—Sketch showing Triangulation at Mouth of Savage River, to determine Middle of Mouth and Terminal Point of Boundary Line.

DETERMINATION OF "MIDDLE OF MOUTH OF SAVAGE RIVER" (POINT M).

The triangulation, as carried out by the two surveyors, for the determination of this point is shown in the accompanying sketch (Fig. 12). From their note-books I extract the following information:

“The Potomac river near the mouth of the Savage river makes several sharp curves forming a letter S. At this point the waters of both rivers flow against a thick ledge of hard sandstone rock, which forms the base of Franklin hill (see Plate IX, Fig. 2). The waters of the rivers, which were high at the time (July 19), are of different color, and thus aided materially in determining the ‘middle of Savage river where it empties into the Potomac.’ A 100-foot tape was stretched across the water along the dividing line of the two rivers, from the point *R* to point *E* in the sketch (Fig. 12), and the distance found to be 86 feet. One-half of this gave us the middle of the Savage as called for by the act—the point *M* in the sketch. The water being deep and the current swift, we transferred the point *M* by triangulation to the north bank of the Savage—to the point *M*<sub>1</sub>.”

At the point *M*<sub>1</sub>, I had previously planted a pole which had been sighted upon from Daniels triangulation station. The point is marked by a half-inch hole drilled in a large, solid, flat rock projecting out of the hillside about 40 feet above the level of the river. The rock is large enough for a tripod to be comfortably placed upon it. 3½ feet to the west is a white oak tree (see Plate IX, Fig. 2), about one foot in diameter. It made an excellent triangulation station. The angles obtained by the surveyors with their transits are:

Angle.	
<i>RM</i> <sub>1</sub> <i>E</i>	.....72° 31' 13"
<i>M</i> <sub>1</sub> <i>ER</i>	.....64 15 53
<i>ERM</i> <sub>1</sub>	.....43 12 54

Since *RE* = 86 feet, we find by calculation that *EM*<sub>1</sub> = 61.738 feet, *M*<sub>1</sub>*R* = 81.220 feet, *MM*<sub>1</sub> = 57.924 feet, and angle *MM*<sub>1</sub>*E* = 41° 58' 06". As angle between Daniels triangulation station and point *E* is 25° 50' 26", angle *M*<sub>2</sub>*M*<sub>1</sub>*M* = 180° — (25° 50' 26" + 41° 58' 06" = 67° 48' 32") = 112° 11' 28". True bearing of line *M*<sub>1</sub>*D* as obtained by solar azimuth observations at Daniels is S. 33° 02' E. Approximate true bearing of boundary line is S. 26° W. (see foot-note p. 108); hence angle *MM*<sub>2</sub>*M*<sub>1</sub> = 33° 02' + 26° = 59° 02'. With the aid of these data we find *M*<sub>1</sub>*M*<sub>2</sub> = 10.29 feet, and *MM*<sub>2</sub> = 62.55 feet. Hence the “middle of Savage river where

it empties into the Potomac" is 62.55 feet in the direction of the boundary line from the point  $M_2$ , where the triangulation line  $M_1D$  (see Figs. 9 and 12) prolonged intersects the boundary line.

When the line  $M_1D$  was extended backwards and the distance  $M_1M_2 = 10.29$  feet was laid off, it was found to coincide with the lower left hand corner of a large rock lying flat against and firmly bedded in the hillside,  $6\frac{1}{2}$  feet to the west of the white oak tree shown in the sketch (Fig. 6 and Plate IX, Fig. 2). The rock measures 1.25 feet in direction up the hill and 3.2 feet in direction along the hill. When the line was permanently marked, the point  $M_2$  was referred to the bolt and mound shown in the sketch. Horizontal distance of  $M_2$  from the bolt is 34.14 feet, and from mound (middle of hole in top of marble post) 40 feet. Hence the "middle of the Savage river where it empties into the Potomac" is 28.4 and  $102\frac{1}{2}$  feet, measured horizontally along the boundary line from the bolt and the mound respectively. For description of bolt and mound see page 133. The point  $E$  has likewise been marked by a cross cut in the rocky ledge, so that with the aid of the data given above  $M$  can also be recovered from  $E$ .

In the main triangulation system the pole sighted upon was always at  $M_1$ , *i. e.* the triangulation station representing the "mouth of the Savage" was a so-called "eccentric one." The simplest way of making the proper correction in the computation so as to refer  $M_1$  to the "mouth" was by substituting for the point  $M_1$  the point  $M_2$ , obtained with the aid of the known approximate bearing of the boundary line. And as  $M_2$  was in the same line with  $M_1$  and  $D$ , it was only necessary when solving the triangles of the main system to substitute instead of the side  $M_1D$  the side  $M_2D$ .

#### DETERMINATION OF TERMINAL POINT OF ENTIRE BOUNDARY LINE.

This point was to be the terminal point of a straight line connecting the middle of the mouth of the Savage river ( $M$ ) with the nearest point of the boundary of the state of West Virginia (the further bank of the Potomac). This point was determined by Mr. Beall and then referred by triangulation to the station  $M_1$  by Messrs. Beall and Brown. The angles measured for this purpose were:



Angle.	Observer.	Observed.
$TM_1E$	Brown	$25^{\circ} 30' 26''$
$ERT$	Beall	63 30 22
$RET$	Brown	77 43 45

With the aid of these quantities we find that the horizontal length of  $ET = 122.9$  feet, and of  $M_1T = 175.6$  feet, and of  $MT = 121\frac{1}{2}$  feet.

These data will suffice to enable one to recover  $T$  from any of the points (bolt, cross,  $M_1$ ,  $M_2$ , mound).

#### THE INITIAL POINT OF THE LINE.

This, according to the act of 1872, was to be "at the summit of Big Back Bone or Savage mountain, where that mountain is crossed by Mason's and Dixon's line." On July 20th the two surveyors and I went to the top of Savage mountain in order to determine the starting point of our line. A mound on the top of the mountain, about 50 yards south of the gate-house of the Standard Oil Pipe Line, had been pointed out to me by Mr. C. Bolden, living in the vicinity, as being doubtless one of the Mason and Dixon mounds.

In this region the real Mason and Dixon line was in dispute. Two lines differing 100 feet and more have been taken at various times as the state boundary line. The original mounds seemed to have been lost, and, unfortunately, the corners of the old military lots were likewise marked by mounds, so that it was difficult to vouch for the authenticity of a mound found in this locality. The engineer who laid out the pipe line was instructed to remain everywhere 10 yards away from the Mason and Dixon mounds. Not finding any authentic mounds in this locality, he went far enough away to be surely in Pennsylvania. When he had run west several miles, he found authentic mounds again and switched his line back again, introducing thus a very noticeable crook in his line.

We were accordingly, obliged to spend more time in the determination of the initial point than we had bargained for. We first ran a line due east from the mound pointed out by Mr. Bolden, and levels were taken by Messrs. Brown and Beall. The result of these levels

is shown in Fig. 13. The highest point, as agreed upon by Messrs. Beall and Brown, was 278 feet due east of the center of the mound. This point was temporarily accepted as the initial point of the boundary line. It was found, furthermore, that the crest of the mountain for nearly 100 yards ran in the direction of the boundary line, hence a very precise determination of the point of the crest where the true Mason and Dixon line crossed was not essential for the purpose of running the boundary line we were called upon to trace. I therefore decided to make the point determined by the surveyors my triangulation station, and, in fact, traced out the entire line from this point.

This point has since been found, in 1902, by Captain W. C. Hodgkins of the U. S. Coast and Geodetic Survey, the engineer in charge in behalf of the states of Maryland and Pennsylvania for re-tracing the

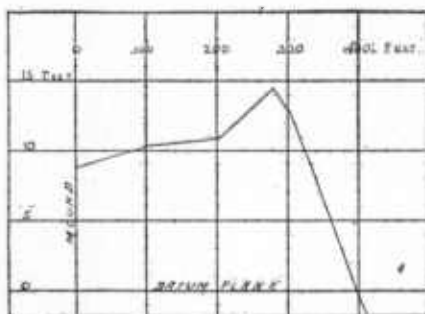

FIG. 13.—Profile of line of levels across the top of Big Savage Mountain.

the state line and has been permanently marked by him.

In 1898, when the true location of the Mason and Dixon line was, as stated, a matter of dispute, the following additional work was done in order to test the point from which the boundary line was traced.

Messrs. Beall and Brown ran a due west line for nearly a mile and likewise examined a large stone mound  $2\frac{1}{2}$  miles to the west. No entirely conclusive evidence as to the real state line could, however, be obtained. It was therefore decided that Mr. Beall should examine the mounds to the east of the Big Savage mountain, viz.: the one on the top of Little Allegany mountain, about 5 miles away, and the other on the top of Wills mountain, 9 miles from the top of Savage mountain. It was found that according to the Mason and Dixon line as defined by these two mounds, my triangulation station, referred to above, was 42.05 feet too far south. I, accordingly,

placed a temporary initial monument, 46.82<sup>1</sup> back of my triangulation station and in the direction of the boundary line. In the winter of 1902, when Captain Hodgkins determined the true location of the Mason and Dixon line he found, as already stated, that my triangulation station was situated on the Mason and Dixon line and that the reason it appeared in 1898 to be too far south by 42.05 feet was because of there being a cusp in the original Mason and Dixon line to the east of Savage mountain. He, accordingly, under authority of the State Geologist, moved the temporary initial monument above mentioned to a point southward, coinciding practically with my triangulation station; the distance the temporary initial monument of 1898 was moved along the line southward was 45.6 feet.

#### THE MARKING OF THE BOUNDARY LINE.

##### THE MANNER OF MARKING.

Section 2 of the act creating the survey designates that the boundary line shall be permanently marked at its terminal points, and that along the same shall be planted suitable stones properly marked at intervals of not over a mile. A great deal of thought was spent upon the kind of monuments to be planted along the line. The monuments must be such as to insure their not being disturbed or destroyed for a long time to come. The appropriation was not sufficient to warrant our having stones especially cut and lettered for the purpose and to defray the cost of their transportation to the tops of the many high, steep hills and mountains along the line. Nor has it been found especially desirable in the marking of boundary lines to have as a marking stone one possessing an inherent commercial value. It was finally decided to mark the line in the following manner. A hole 2-3 feet square and about 2 feet deep was dug. At the bottom of this hole was placed a good, substantial, flat stone obtained in the vicinity, usually about 4 inches thick and squaring from two to four feet. A hole drilled in this subsurface stone or a cross cut in it marked the precise point of the line. On top of the flat stone

<sup>1</sup> 42.05 feet multiplied into the secant of the true bearing of the boundary line, N. 26° 04.9' E.= 46.82 feet.



FIG. 1.—CONFLUENCE OF SAVAGE RIVER AND NORTH BRANCH OF THE POTOMAC.



FIG. 2.—TRIANGULATION STATION ( $M_1$ ).

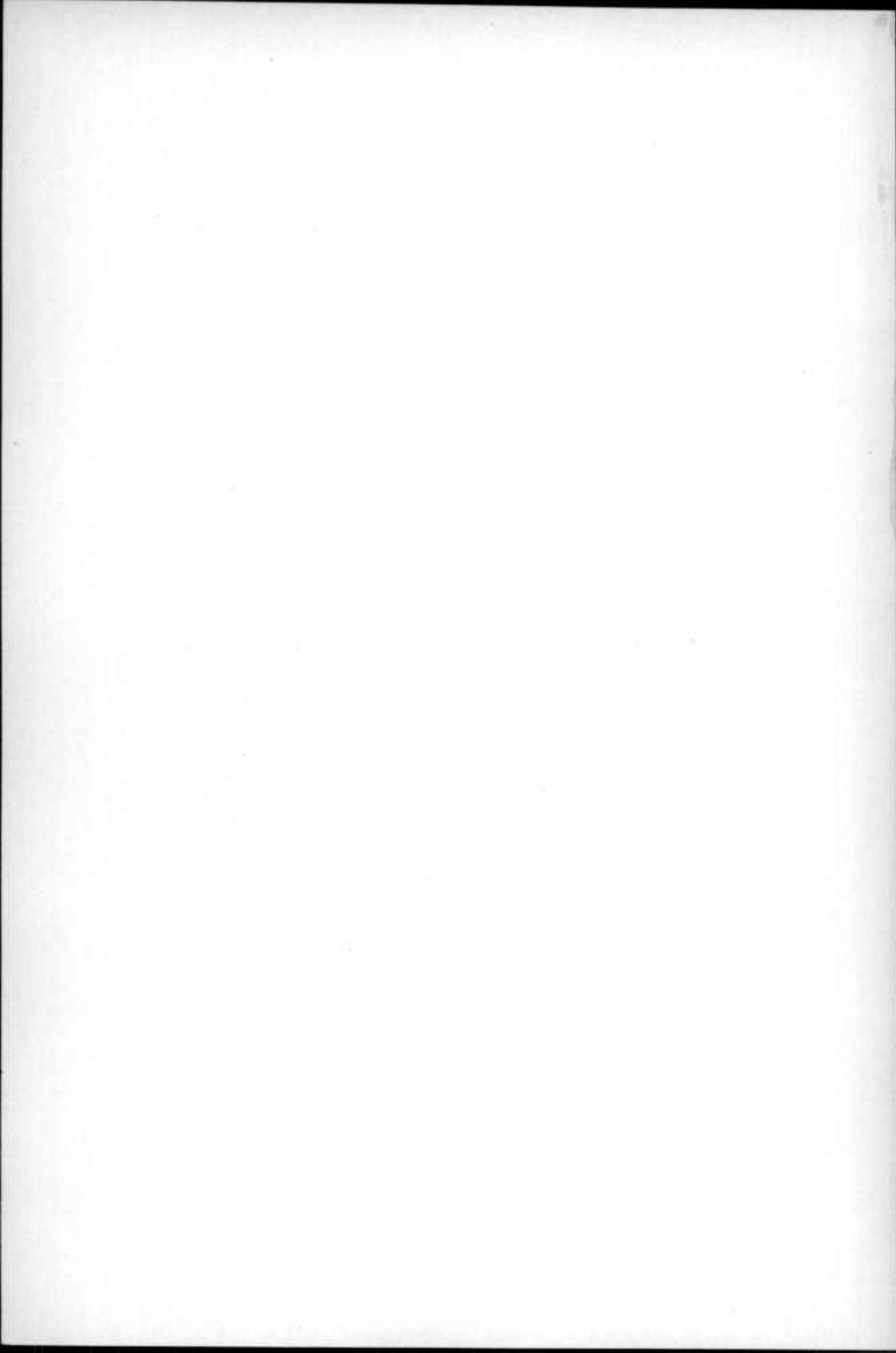

was next placed the surface marking stone. The surface stone was a rough sandstone also obtained in the vicinity, one so large as to require two or three men in handling it. The length was about three feet; the top was 50 square inches and more. A cross or a hole in the top of the stone marked the precise point. Around the marking stone was raised a mound, 8 feet in diameter, generally consisting of earth and stones and coming up to the top of the stone or to within a few inches of the top. The marking stone was then most firmly packed and braced on all sides. Finally a trench 6-8 inches deep and a foot wide was dug around the mound.

In placing the mounds we were governed by the following considerations, as far as the scanty funds at our disposal would permit:

1. From any one mound at least one other mound should be visible or might be made visible with a little cutting or by the planting of a pole on the mound, so that the surveyor could get the direction of the line from the mounds for the purpose of locating intermediate points.

2. The mounds were not to be over a mile apart, as called for by the act. (This provision occasionally obliged us, on account of the nature of the ground, to put in additional mounds at intervals of very much less than a mile.)

3. A mound should be put on the highest ground in the vicinity whenever circumstances permit and provision (2) is not violated thereby.

4. A mound should be placed as far as possible near a fence, a road or some easily described place. It should never be in an open field where it is exposed to the ravages of the ploughshare.

In a total distance of 18.6 miles 25 mounds of the above description were constructed.

#### LOCATION OF THE MOUNDS.

As the mounds were all constructed in the same manner, no detailed description of each is necessary. Simply such information will be given as will enable one to find a desired mound. I shall begin with the mound on the Mason and Dixon line, as the act requires the line to begin at this point. No number will be found marked on the boundary stones. The number was omitted so as to prevent the natural inference that they are milestones; as above-mentioned the stones could not be placed exactly a mile apart.

1. Mound on Mason and Dixon line. "On the summit of Big Backbone or Savage mountain, where that mountain is crossed by Mason's and Dixon's line." Reached by mountain road from Mount Savage railroad station. A more roundabout way, but a better road, is from Frostburg by way of Finzell postoffice. The gate-house of the Standard Oil Pipe Line is about 70 yards to the north of the mound.

The monument is tightly wedged between two ledges of rock with stones piled around. A hole 1 inch in diameter and  $\frac{3}{4}$  inch deep was drilled in the top of the western and higher rock 3.74 feet west of the monument. This stone monument can be replaced easily in case it should be thrown out of position in some manner with the aid of the following marks:

(1) An expansion bolt<sup>1</sup> driven in a sandstone rock 109.1 feet forward (i. e. southward) of the center of hole in monument.

(2) Two similar bolts, 22 $\frac{3}{4}$  feet and 60 $\frac{3}{4}$  feet, respectively, driven in solid sandstone rocks, back of center of hole in monument.

The boundary line passes through the centers of these three bolts.

[The above description applies to the present (1903) site of the initial mound. As already related on page 128, the temporary initial mound was 45.6 feet back of the present one.]

2. Mound on Mount Savage fire-clay hill. About 500 feet from second dump on fire-clay incline plane. Most easily reached from Mount Savage or from Finzell. Marking stone is 3 $\frac{1}{2}$  feet high and 8 x 10 inches square, with a hole in top marking precise center. Mound, trench, subsurface stone as prescribed. Pitch pine tree 18 inches in diameter stands about 9 feet north of mound.

3. Mound on Piney Hill, better known as Cranberry Hill. About 300 feet east of mountain road known as Cranberry road, running north from National Road to fire-clay mine. The subsurface stone is about 5 inches thick with center marked on it; on this was placed a stone 2 $\frac{1}{2}$  feet high and 5 x 10 inches square with hole in top. Mound and trench around the stone as usual.

4. Mound on Roaring Hill. About one mile north of National Road, where old toll-gate formerly was, not far from house occupied at present by John Workman. A subsurface stone (with center), mound and trench as usual. The upper stone is 2 feet long and 5 x 12 inches square, the longer dimension being along the line. A drill hole started in top of stone marks precise point.

5. Mound on National Road, 1 $\frac{1}{2}$  mile from Frostburg, on south side of pike and about 56 feet west of iron columns marking site of old toll-gate. The principal stone is dressed, of white marble, 3 feet long and 6 x 6 inches square, with corners rounded off to prevent chipping. A  $\frac{1}{4}$ -inch hole in top marks precise point, and the top of stone is lettered as follows:

<sup>1</sup> These bolts wedge tight in driving; the head is one inch square, and they are  $\frac{1}{2}$  inch in diameter and 2 $\frac{1}{2}$  inches long.



.....  
 Md. G. S.  
 —  
 1898  
 .....

On the east side of stone is the letter *A* and on the west side *G*. The monument rests on a flat rock (the subsurface mark) and is set in a mixture of broken stone and hydraulic cement. The usual mound and trench surround the monument.

6. Mound on hill south of National Road. About  $\frac{3}{4}$  of a mile south of pike, between two runs, on level piece of cleared ground near an old road and near Frostburg pipe line for water supply, and not many feet west of artesian well. The upper rock is  $2\frac{1}{2}$  feet long and about 6 inches square on top. A drill hole started in top marks center. Subsurface stone, mound (9 feet in diameter) and trench as usual.

7. Mound near old Braddock road, on hill north of Winebrenner run,  $1\frac{1}{2}$  mile north of Midlothian. The mound is about 50 yards north of the Braddock road. The upper stone is about 3 feet long, 8 inches square, rudely dressed and with center marked in top. Subsurface mark, mound and trench as prescribed.

8. Mound on hill south of Winebrenner run.  $\frac{3}{4}$  of a mile northwest of Midlothian. On the face of hill sloping toward N. E., upon lower part of spur, about half-way to top of hill and near an old log road, one-quarter of a mile south of Benjamin Filer's house, which is in sight. The upper stone is 2.2 feet long and 8 inches square on top with center marked. Subsurface stone, mound and trench as usual.

9. Mound on hill north of Staub Run. About  $\frac{3}{4}$  of a mile northwest of Carlos, on farm belonging to William Filer. In the woods, about 100 yards south of rail fence at brow of hill, where miner's path intersects fence. This path leads down to road coming out at Carlos. The upper stone is a red sandstone, about 5 inches thick and about  $2\frac{1}{2}$  feet long, with hole drilled in top. Subsurface stone, mound, trench. Mound had to consist chiefly of stone.

10. First mound on hill south of Staub Run. About  $\frac{3}{4}$  of a mile west of Carlos. Take road as far as William Filer's house, then follow miner's path to mine opening about  $\frac{1}{2}$  mile, then bear to the right to cutting. The hill belongs to the Consolidation Coal Company.

11. Second mound on hill south of Staub's run. About 268 paces south of first mound. The two mounds were placed so near to each other so as to give intervisible points to the north and south. From north mound, mounds 9, 7, 4 and 1 are visible (or can be made so), and from south mound No. 12 can be seen.

12. Mound on north side of Koontz Hill. South of Wright's Run and reached from either Lonaconing, Midland or Ocean. A road passes within 20 yards of the mound and continues northward on down the hill to Ocean, or southward past Cutter's barn down the hill to Lonaconing. Not a very good looking stone, but a substantial one, forms the principal stone. The mound consists chiefly of stone.

13. Mound on south side of Koontz Hill. About 2 miles northwest of Lonaconing. On the south side of lane leading to the west of gate to Cutter's barn and house, and 70 yards from the gate. The farm belongs to the New Central Coal Co., and is rented by Barney Cutter, whose brother, Henry, is at present living on the place. The precise point is marked by a cross cut in stone,  $3\frac{1}{2}$  feet long and about 7 x 7 inches square. In center of cross was drilled a  $\frac{1}{8}$ -inch hole. From this mound, mound No. 15 can be seen by planting a pole on top of it.

14. Mound on Pea Ridge road. On the north side of the road leading from Lonaconing to Pea Ridge, about  $1\frac{1}{2}$  mile from Lonaconing. Center stone is about 13 inches square and about  $3\frac{1}{2}$  feet long, resting about 2 feet in the ground. Precise point was marked with a pick in center of stone. No subsurface mark. Mound about  $1\frac{1}{2}$  foot high and 6 feet in diameter, consisting of earth and stone thrown up against center stone.

15. Mound on hill west of Lonaconing. On property of Maryland Coal Company; near fence on west side of meadow south of house occupied by Mr. Weir, who is the present tenant of the farm. Precise point is marked by a cross and  $\frac{1}{4}$ -inch hole in center of top of central stone of mound. Subsurface stone, mound and trench as usual. From this mound are visible several points in the line as far south as Franklin Hill.

16. Mound on Detmold Hill. On the west end and on the highest point of the hill. Reached by Miller road running from Detmold to Grantsville, within about  $\frac{1}{4}$  of a mile to the west of mound. Mound is built on an undisturbed, solid stone with subsurface mark on it, and around a smooth, upright stone, 3 feet long and 6 x 9 inches on top.

17. Mound near Miller road. South of Detmold Hill, between Laurel Run and Miller road, which runs from George's Creek road to Grantsville; one rod north of road and about  $\frac{1}{4}$  of a mile from Robert Green's farm. The precise point is marked by a hole in the central stone, which is 3 feet long and 8 x 10 inches on top. Subsurface mark, mound, trench.

18. Stone on North Pickell Hill. About  $\frac{1}{4}$  mile to the north of next mound (No. 19). No mound was built, but simply a stone 2 feet long and 4 x 14 inches on top was set in the ground and stones firmly packed around it. The stone is north of a road to meadow on hill. Coal mines are on fire on this hill.

19. Mound on South Pickell Hill. Reached from Barton by taking county road to Grantsville, or also from Moscow, mound being about 2 miles west of latter point. Constructed in the usual manner. Precise point is a cross cut in top of central stone.

20. Mound on Bartlett Road. On county road leading from Barton to Grantsville, about  $1\frac{1}{2}$  rod north of road, on land owned by Wm. Sommerville. Constructed in the prescribed manner.

21. Mound on Swanton Hill. Reached from Barton by a very steep road to top of hill. Mound is about 40 paces north of barbed-wire fence dividing the American Coal Co. property from that of the Swanton Coal Co. The precise location can be pointed out by Peter Shaw, who lives on top of hill. The central stone of the mound has a cross cut in the top and the letters A and G rudely cut in the sides. Franklin Hill mound (No. 24) can be seen from this point; also No. 15.

22. Mound on Phoenix Hill. Reached from Morrison switch by taking Phoenix Hill road. It is on the summit of the hill in a meadow owned by Davis Coal Co. and leased by John Lannon. Built in the usual manner.

23. Monument on county road south of Phoenix Hill. Reached from Franklin railroad station. On the north side of the road. A good, substantial stone firmly set in the ground and smaller stones packed around it. The mound is about three rods east of U. P. Gannon's house.

24. Mound on north side of Franklin Hill. On the highest point of the hill reached by the line. About 50 feet to the south the hill breaks off very abruptly and only a short distance beyond the tramway curves around the hill to the west. The central stone is about  $2\frac{1}{2}$  feet long and about 12 inches square. A cross cut in the top marks the precise point. Subsurface stone, mound and trench.

25. Mound on south side of Franklin Hill. About 20 yards north of county road where it crosses bridge over the Davis coal mine plane. The subsurface is a cross cut in a sandstone about  $1\frac{1}{2}$  foot long, 8 inches wide and 10 inches thick lying with the longer dimension at right angles to the line. On this solid stone rests a dressed marble post  $2\frac{1}{2}$  feet long and 6 inches square. Around the stone is a mound 8 feet in diameter, consisting of earth and stone; a trench encircles the mound. The stone is lettered on top:

```

.....
: Md. G. S. :
:           :
:  1898    :
:           :
:           :
.....

```

On the west side is the letter *G* and on the east side *A*. The precise center is marked by a half-inch hole drilled in the top of the stone.

26. Mound at mouth of the Savage. On the south side of the road leading to Bloomington about 100 feet above the Savage River. The central stone is a dressed marble post,  $2\frac{1}{2}$  feet long and 6 inches square, marked and lettered as in the case of No. 24.

27. Bolt in rock at mouth of Savage river. Set with plaster of paris in a good firm rock close to the river. Bolt is  $\frac{3}{4}$  inch in diameter; head about  $1\frac{1}{4}$  inch round. For references and distances to other marks at the mouth of the Savage, see page —.

#### MAGNETIC WORK DONE IN CONNECTION WITH THE BOUNDARY LINE.

I found it impracticable with the limited time and funds at my disposal to transport the special magnetic outfit to the tops of the many high hills along the line. Instead of this, Mr. Brown, whose magnetic needle was in very excellent condition, was instructed to read his needle whenever opportunity afforded. On a subsequent page are given the data for determining the approximate correction to be applied to Mr. Brown's results in order to reduce them to those

Magnetic Readings taken by Surveyor Brown, with the needle of his transit, at various points along the Boundary Line.

Station.	Date, 1898.	Time of day (Eastern time).	Magnetic Bearing of Mark.	True Bearing of Mark.	Mag'tic declination (West).	CORRECTIONS.			Mean Magnetic Declination in 1898½ (West).	
						Index.	Diurnal Variat'n	Secular Variat'n		
		h m	° /	° /	° /	/	/	/	° /	
Mound 1 <sup>1</sup> . . . .	July 20	3 30 p	S 85 50 E	S 90 02.2 E	4 12.2	-1.0	-3.4	-0.1	4 07.7	
Mound 2 . . . . .	Aug. 29	3 50 p	N 30 15 E	N 26 04.8 E	4 10.2	-1.0	-2.2	-0.5	4 06.5	
Sampson Rock. . .	July 30	1 30 p	S 18 05 W	S 14 17.7 W	3 47.3	-1.0	-4.8	-0.2	3 41.3	
		2 00 p	S 18 25 W	S 14 17.7 W	4 07.3	-1.0	-4.8	-0.2	4 01.3	
		5 30 p	S 18 28 W	S 14 17.7 W	4 10.3	-1.0	-0.5	-0.2	4 08.6	
		1 30 p	S 72 30 W	S 68 33.8 W	3 56.2	-1.0	-4.8	-0.2	3 50.2	
		2 00 p	S 72 45 W	S 68 33.8 W	4 11.2	-1.0	-4.8	-0.2	4 05.2	
		5 30 p	S 72 35 W	S 68 33.8 W	4 01.2	-1.0	-0.5	-0.2	3 59.5	
		2 00 p	S 7 00 E	S 11 05.4 W	4 05.4	-1.0	-4.8	-0.2	3 59.4	
		5 30 p	S 7 02 E	S 11 05.4 W	4 03.4	-1.0	-0.5	-0.2	4 01.7	
Mean									3 58.4	
Mound 4 . . . . .	Aug. 27	4 30 p	N 30 11 E	N 26 04.3 E	4 06.7	-1.0	-1.1	-0.5	4 04.1	
Mound 5 . . . . .	Aug. 29	12 30 p	N 30 15 E	N 26 04.1 E	4 10.9	-1.0	-4.7	-0.5	4 04.7	
Mound 7 . . . . .	Aug. 25	9 50 a	N 30 05 E	N 26 04.3 E	4 00.7	-1.0	+0.9	-0.5	4 00.1	
		1 50 p	N 30 12 E	N 26 04.3 E	4 07.7	-1.0	-4.8	-0.5	4 01.4	
		3 50 p	N 30 10 E	N 26 04.3 E	4 05.7	-1.0	-2.1	-0.5	4 02.1	
		Aug. 26	10 20 a	N 30 03 E	N 26 04.3 E	3 58.7	-1.0	-0.6	-0.5	3 56.6
			12 15 a	N 30 10 E	N 26 04.3 E	4 05.7	-1.0	-4.7	-0.5	3 59.5
Mean									3 59.9	
Mound 8 . . . . .	Aug. 26	2 00 p	N 30 11 E	N 26 04.3 E	4 05.7	-1.0	-4.8	-0.5	3 59.4	
Mound 10 . . . . .	Aug. 23	10 50 a	N 30 06 E	N 26 03.4 E	4 04.6	-1.0	-2.8	-0.4	4 00.4	
		1 30 p	N 30 08 E	N 26 03.4 E	4 04.6	-1.0	-4.9	-0.4	3 58.3	
		4 00 p	N 30 05 E	N 26 03.4 E	4 01.6	-1.0	-1.8	-0.4	3 58.4	
		Aug. 24	9 15 a	N 30 02 E	N 26 03.4 E	3 58.6	-1.0	+2.0	-0.4	3 59.2
			2 00 p	N 30 02 E	N 26 03.4 E	3 58.6	-1.0	-4.1	-0.4	3 53.1
Mean									3 57.9	
Mound 13 . . . . .	Aug. 22	9 25 a	N 29 59 E	N 26 02.1 E	3 56.9	-1.0	+1.8	-0.4	3 57.3	
		1 00 p	N 29 52 E	N 26 02.1 E	3 49.9	-1.0	-5.0	-0.4	43.5	
Mean									3 50.4	
Mound 15 . . . . .	Aug. 19	2 15 p	N 30 03 E	N 26 02.4 E	4 00.6	-1.0	-4.6	-0.4	3 54.6	
Mound 18 . . . . .	Aug. 31	5 30 p	N 29 59 E	N 26 00.9 E	3 58.1	-1.0	-0.2	-0.5	3 56.4	
Mound 19 . . . . .	Aug. 31	2 30 p	N 30 02 E	N 26 00.9 E	4 01.3	-1.0	-4.2	-0.5	3 55.6	
Mound 21 . . . . .	Aug. 18	9 43 a	N 29 50 E	N 26 01.3 E	3 48.7	-1.0	+1.2	-0.4	3 48.5	
		10 43 a	N 29 53 E		3 51.7	-1.0	-1.8	-0.4	3 48.5	
		3 00 p	N 29 58 E		3 56.7	-1.0	-3.7	-0.4	3 52.6	
Mean									3 49.9	
Mound 23 . . . . .	Aug. 20	5 15 p	N 29 50 E	N 25 59.7 E	3 50.3	-1.0	-0.4	-0.4	3 48.5	
Mound 24 . . . . .	Aug. 20	12 30 p	N 29 52 E	N 25 59.6 E	3 53.4	-1.0	-4.9	-0.4	3 47.1	
		2 40 p	N 29 52 E	N 25 59.6 E	3 53.4	-1.0	-4.1	-0.4	3 47.9	
Mean									3 47.5	
Mark 27 <sup>2</sup> . . . . .	July 19	about 4 p	S 29 52 E	S 33 02.9 E	3 10.9	-1.0	-3.0	-0.1	3 06.8	
			S 29 50 E	S 33 02.9 E	3 12.9	-1.0	-3.0	-0.1	3 08.8	
			N 89 46 W	N 93 01.5 W	3 15.5	-1.0	-3.0	-0.1	3 11.4	
			N 89 50 W	N 93 01.5 W	3 11.5	-1.0	-3.0	-0.1	3 07.4	
			S 29 57 E	S 33 02.9 E	3 05.9	-1.0	+0.8	-0.3	3 05.4	
Aug. 11	4 00 p	S 29 57 E	S 33 02.9 E	3 05.9	-1.0	-1.9	-0.3	3 02.7		
Mean									3 07.1	
Daniels Δ . . . . .	July 28	2 00 p	N 29 45 W	N 33 02.1 W	3 17.1	-1.0	-4.8	-0.2	3 11.1	

<sup>1</sup> At triangulation station, 46.84 feet from Mound 1 and forward along boundary line.

<sup>2</sup> At triangulation station M<sub>1</sub>, 28 feet north of bolt.

obtained with the instrument used in the magnetic survey of Maryland, viz. Coast and Geodetic Survey magnetometer No. 18.

Complete magnetic observations, *i. e.* magnetic declination, magnetic inclination and intensity of magnetic force, were made by me with the special magnetic outfit at two places near the line: at Westernport in 1897 and at Lonaconing on August 31, 1898. Only the results for magnetic declination need be given herewith.

Station.	Date.	Magnetic decl'n approximately reduced to mean of day.
Westernport,	Aug. 3, 1897.	3 46.2 West
Louacouling,	Aug. 31, 1898.	3 51.0 "

The station at Westernport is on north side of hill, along road leading down to the river from W. Va. R. R. station, and about 100 yards east of last house. The station at Lonaconing is in south part of base-ball field, south of Maryland Coal Company's office. The precise point at Lonaconing is marked by a locust stake and can be pointed out by Mr. F. E. Bracket.

Mr. Brown states that none of his magnetic readings is the result of one reading alone, but always the average of two or more readings, the needle having been lifted between times.

The corrections applied to the observed magnetic declinations in the foregoing table were derived as follows:

I.—Index or Needle Correction The data furnishing the correction to be applied to the declinations observed with Mr. Brown's needle, are:

Station.	Date, 1898.	Eastern time.	Brown's obs'd mag'c decl'n.	Mean Magnetic Decl'n.		Correc. tion to Brown's needle.
				Brown.	Bauer.	
1. Oakland C. H. Meridian,	June 24.	10 50 a	3 26.5	3 25.4	3 25.7	+0.3
2. Lonaconing Mag. S. station,	Sept. 1.	4 12 p	3 55.9	3 54.6	3 51.0	-3.6
3. Corunna Meridian.	Sept. 5.	10 40 a	3 22	3 20.3	3 19.5	-0.8

Brown remarks that Nos. 1 and 3 were observed in shade and No. 2 in hot sun. Bauer's magnetic declinations for Nos. 1 and 3 are the values obtained in 1897 with Coast and Geodetic Survey Magnetometer 18, reduced to date of Brown's observations; the value for No. 2 was obtained on Aug. 31, 1898, with same magnetometer.

Correction adopted to be applied to Brown's values,  $\frac{1}{3}[+0.3 + \frac{1}{2}(-3.6 - 0.8)] = -1'.0$

II. Correction on account of diurnal variation. See my table for reducing an observed magnetic declination to mean of day, p. 457 in First Report on Magnetic Work in Maryland, in Vol. I, Md. Geol. Survey. This table has been reproduced on p. 138, but with the signs reversed.

III. Secular variation correction. At the rate of 3' per annum; all of Brown's observed magnetic declinations have thus been reduced to the middle of year of survey—1898  $\frac{1}{2}$ .

Collecting the various results obtained, we have the following values of the magnetic declination in the region traversed by the boundary line.

*Summary of the Values of the Magnetic Declinations along the Boundary Line.*

Station.	Latitude. <sup>1</sup>		Longitude <sup>1</sup> W. of Gr.		Mean magnetic declination in 1888½.	Observer.	Normal magnetic declination in 1888½		Difference.
	°	'	°	'			°	'	
Mound 1	39	43.4	78	54.8	4 07.7 W	W. M. B.	4 07.7	0.0	
Mound 2	39	42.5	78	55.4	4 06.5	"	4 06.6	+0.1	
Sampson Rock	39	42.5	78	55.8	3 58.4	"	4 06.6	+8.2	
Mound 4	39	41.2	78	56.1	4 04.1	"	4 04.6	+0.5	
Mound 5	39	40.5	78	56.6	4 04.7	"	4 03.6	-1.1	
Mound 7	39	39.3	78	57.3	3 59.9	"	4 01.7	+1.8	
Mound 8	39	38.6	78	57.7	3 59.4	"	4 00.8	+1.4	
Mound 10	39	37.3	78	58.5	3 57.9	"	3 58.8	+0.9	
Mound 13	39	35.7	78	59.5	3 50.4	"	3 56.4	+6.0	
Mound 15	39	34.7	79	00.1	3 54.6	"	3 55.0	+0.4	
Mound 18	39	33.0	79	01.2	3 56.4	"	3 52.1	-4.3	
Mound 19	39	32.8	79	01.3	3 55.6	"	3 52.1	-4.5	
Mound 21	39	31.8	79	01.9	3 49.9	"	3 50.8	+0.9	
Mound 23	39	30.1	79	03.0	3 48.5	"	3 48.2	-0.3	
Mound 24	39	29.7	79	03.3	3 47.5	"	3 47.5	0.0	
Mark 27	39	28.8	79	04.0	3 07.1	"	3 46.2	+39.1	
Daniels Δ	39	28.0	79	02.7	3 11.1	"			
Lonaconing	39	33.6	78	59.1	3 50.5	L. A. B.			
Westernport	39	28.9	79	02.2	3 48.9	"			

<sup>1</sup> The latitudes and longitudes here given have been scaled from the topographic sheets of the U. S. Geological Survey with exception of Mounds 1 and 27 and Sampson Rock.

By looking over the figures in the fourth column it will be noticed that the magnetic declination decreases quite uniformly from the initial point of the line on the top of Savage mountain to Franklin hill (mound 24). The total change is 20'.2 in a total distance of 17½ miles, or the rate of decrease is 1'.15 per mile. The same thing is shown by my chart of the lines of equal magnetic declination published in the "Second Report on Magnetic Work in Maryland." From this chart we find that the normal value of the magnetic declination for middle of this year would be about 3° 46' at the mouth of the Savage and 4° 06' at the initial point of the boundary line.

*There exists, however, a decided local attraction at the mouth of the Savage river, the needle being thrown out of its normal direction by ⅔ of a degree—see last column of table.*

The declination on Daniel's farm, back of Piedmont, appears to be disturbed by about the same amount.

*Additional Magnetic Data Obtained by Mr. Brown, After the Completion of the Survey of the Boundary Line.<sup>1</sup>*

Station.	Date, 1899.	Time of Day (Eastern Time).	Magnetic Bearing of Mark.	True Bearing of Mark.	Magn'tc Decl'n (West).	Corrections.			Mean Magn'tc Decl'n in 1898.5 (West).	
						Index.	Diurnal Var'n.	Secular Var'n.		
		h. m.	° /	° /	° /	/	/	/	° /	
Mound 8	Jan. 18	2 00 p	N30 08. E	N26 03.3E	4 04.7	-1.2	-2.6	-1.7	3 59.2	
9	" 19	9 50 a	N30 07. E	N26 03.0E	4 04.0	-1.2	+2.3	-1.7	4 03.4	
13	.....	9 25 a	N29 59. E	N26 02.1E	3 56.9	-1.2	+2.2	-1.7	3 56.2	
14	Jan. 2	2 00 p	N30 01. E	N26 01.8E	3 59.2	-1.2	-2.5	-1.5	3 54.0	
		4 00 p	N30 00.3E	N26 01.8E	3 58.5	-1.2	-1.2	-1.5	3 54.6	
									Mean for Md. 14	
									3 54.3	
21	Jan. 20	4 30 p	N29 57. E	N26 00.6E	3 56.4	-1.2	-0.8	-1.7	3 52.7	
22	" 21	1 20 p	N29 57. E	N26 00.3E	3 56.7	-1.2	-2.6	-1.7	3 51.2	
26 <sup>2</sup>	Feb. 4	2 15	N29 44.0E							
		2 20	N29 45.5E							
			Mean for Md. 26	N29 44.8E	N25 59.3E	3 45.5	-1.2	-2.5	-1.7	3 40.1

These readings were taken with the same needle and instrument as used by Mr. Brown in his previous work and are generally the result of several readings. By comparing these later values with those in the foregoing table, it will be seen that they are in good accord. Mr. Brown also re-occupied my station at Loneoening on December 23, 1898. The value obtained by him reduced to 1898.5 is 3° 50'.9 W.

<sup>1</sup>This table was added in August, 1899.

<sup>2</sup>Over hub twenty feet south of monument in direction of Boundary Line.

COURSES AND DISTANCES.

On following page is a table giving the courses and distances for the various mounds. No additional explanation is needed beyond that already given in the preceding pages.



ALLEGANY-GARRETT BOUNDARY LINE

Number of mound.	Approximate distance from initial mound in tenths of a mile.	True bearing of boundary line at mound.		Magnetic <sup>2</sup> bearing in 1898.5.		Magnetic <sup>2</sup> bearing in 1900.5.	
		°	'	°	'	°	'
1	0.0	S 26	04.9 W	S 30	13 W	S 30	19 W
2	1.0	26	04.6	30	11	30	17
3	1.7	26	04.4				
4	2.7	26	04.1	30	09	30	15
5	3.7	26	03.8	30	08	30	14
6	4.4	26	03.6				
7	5.3	26	03.3	30	05	30	11
8	6.0	26	03.1	30	04	30	10
9	6.9	26	02.8	30	04	30	10
10	7.7	26	02.5	30	01	30	07
11	7.85	26	02.5				
12	8.8	26	02.2				
13	9.8	26	01.9	29	57	30	03
14	10.6	26	01.6	29	57	30	03
15	11.0	26	01.5	29	56	30	02
16	12.0	26	01.2				
17	12.9	26	01.0				
18	13.25	26	00.8	29	55	30	01
19	13.5	26	00.7	29	55	30	01
20	14.1	26	00.6				
21	14.6	26	00.4	29	52	29	58
22	15.65	26	00.1				
23	16.75	25	59.7	29	48	29	54
24	17.4	25	59.5	29	47	29	53
25	18.1	25	59.3				
26	18.6	25	59.1	29	39	29	45
27	18.6	25	59.1	S 29	06 W	S 29	12 W

<sup>1</sup>Note that the number is not marked on stone, but refers to designation as given in "Location of Mounds."

<sup>2</sup>1898.5 and 1900.5 stand, respectively, for middle of year. To get magnetic bearings for subsequent years, add a correction at the rate of 3' per annum. It should be noted that the given quantities are the mean values for the day. To obtain the bearing at any time of the day, apply the corrections given in table below with the sign as affixed.

Month.	6 A. M.	7	8	9	10	11	Noon.	1	2	3	4	5	6 P. M.
Jan. ....	+0.1	-0.2	-1.0	-2.1	-2.4	-1.2	+1.1	+2.5	+2.6	+2.1	+1.3	+0.2	-0.2
Feb. ....	-0.6	-0.7	-1.5	-1.9	-1.4	+0.1	+1.5	+2.1	+2.5	+2.0	+1.2	+0.8	+0.4
March ....	-1.2	-2.0	-3.0	-2.8	-1.6	+0.6	+2.5	+3.4	+3.7	+3.3	+2.3	+1.2	+0.5
April ....	-2.5	-3.1	-3.4	-2.6	-0.8	+2.1	+4.0	+4.1	+4.2	+3.6	+2.3	+1.2	+0.2
May. ....	-3.0	-3.8	-3.9	-2.6	-0.1	+2.4	+4.0	+5.0	+4.5	+3.6	+2.3	+0.9	-0.1
June. ....	-2.9	-4.4	-4.4	-3.3	-1.1	+2.0	+3.6	+4.5	+4.5	+3.8	+2.6	+1.2	+0.2
July. ....	-3.1	-4.6	-4.9	-3.9	-1.8	+1.2	+3.4	+4.4	+4.7	+4.2	+2.8	+1.3	+0.3
August ....	-2.9	-4.9	-5.4	-3.7	-0.4	+2.8	+4.7	+5.1	+4.9	+3.7	+1.9	+0.6	-0.3
Sept. ....	-1.8	-2.8	-3.4	-2.5	-0.3	+2.7	+4.4	+4.6	+4.2	+4.0	+1.4	+0.3	+0.1
Oct. ....	-0.5	-1.6	-3.1	-2.8	-1.4	+1.0	+2.7	+3.3	+3.4	+2.4	+1.3	+0.4	+0.4
Nov. ....	-0.5	-1.2	-1.7	-1.8	-1.1	+0.5	+2.0	+2.7	+2.6	+1.8	+1.0	+0.2	-0.2
Dec. ....	-0.2	-0.3	-0.8	-1.8	-1.8	0.0	+1.6	+2.4	+2.3	+1.8	+1.1	+0.3	-0.1

For example, wanted the magnetic bearing at Mound 5 in June, 1899, at 8.30 a. m.

Magnetic bearing as given by the table in 1898½, S 30° 08' W

Secular change for one year. .... +03

Correction to reduce to 8.30 a. m. .... -04

Magnetic bearing in 1899½ at 8.30 a. m. 30° 07'

MISCELLANEOUS FIELD NOTES.

FIRE CLAY HILL, Union Mining Company's land.—“Boundary line crosses plane about 250 feet above stable.” (Brown.)

ROARING HILL, Borden Mining Company's land.—“Boundary line cuts across porch of house occupied by John Workman, leaving most of it in Garrett county.” (Brown.)

NATIONAL ROAD.—“Boundary line is about 200 feet east of old Frostburg reservoir, and about 19 yards west from center of iron posts marking site of old toll-gate.” (Brown.)

CARLOS.—Boundary line passes east of William Filer's house.

CHISHOLM'S LINE, as pointed out to us, is west of true boundary line, 4307 feet at Mason and Dixon line, 30 feet on Koontz mine hill, at point  $\frac{1}{4}$  mile north of mound 13, 696 feet on hill west of Lonaconing, at point 294 feet north of mound 15, 345 feet at county road north of Franklin hill at mound 23, 32 feet on Franklin hill at point 78 feet south of mound 25, and east of true boundary line 123 feet along road to Bloomington at mound 26.

AZIMUTH OF OBSERVATIONS.—For the purpose of determining the azimuth or bearing of the boundary line, the following determinations of the azimuth of the north end of McKenzie base (the station A on the sketch showing main triangulation) at the triangulation station on Big Savage mountain:

Date, 1898.	Azimuth.	Remarks.
July 20, p. m.	66° 23'. 8	Two sets solar azimuth observations with 4-in. theodolite.
Aug. 3, a. m.	66 24 . 4	“ “ “ “ “ “ “
	Mean 66 24.10	
Aug. 26,	66 24.07	One set, Polaris near eastern elongation with 8-in. theodolite; rain prevented obtaining further results.
Adopted,	66° 24'. 07	

WEATHER.—The very large proportion of cloudy days and nights during the brief time that we were in the field prevented our getting additional azimuth observations. When at last fair weather set in, the appropriation had been exhausted, further field work had to be abandoned, and so we had to leave undone many things that would have been desirable. Thus, for example, at several places it would

have been well to clear out the line a little better. A comparatively small additional appropriation would have sufficed to have cleared out the entire line while we were in the field. Then, again, with the aid of the triangulation stations, the horizontal distances between the various mounds might have been determined with great accuracy could we have spent a few days in the field. This would have been of great benefit in referring land surveys made in the vicinity of the line to established mounds whose positions would be so accurately known that they could always be precisely recovered when lost.

#### LENGTH OF BOUNDARY LINE.

With the aid of the final data referring to the triangulation stations of the U. S. Geological Survey as given on page 117, the length of the boundary line from mound 1, on the Mason and Dixon line to the bolt near the mouth of the Savage river is found to be 98,230 feet.

Since the "middle of the mouth of the Savage river where it empties into the Potomac" is 28 feet from the bolt (see p. 125 and sketch p. 123), the total length of this portion of the boundary line is 98,258<sup>1</sup> feet = 18.61 miles.

The length of the boundary line from the "middle of the month" to the terminal point as stated on p. 126, is 121½ feet.

#### AZIMUTH OF BOUNDARY LINE BETWEEN MOUND 1 AND "MIDDLE OF MOUTH OF SAVAGE RIVER."

From astronomical observations (mainly solar-azimuth observations, see p. 139) we obtain for the azimuth of the boundary line at the initial point (mound 1)

S 26° 05'.12 W.

From the geodetic data on p. 117 we get

S 26° 04'.73 W.

Adopted . . . . S 26° 04'.92 W.

<sup>1</sup> An approximate check upon this value is obtained with the aid of the small McKenzie base (AB of Fig. 9), viz.: 98,365 feet.

At the middle of the mouth of the Savage river the bearing of this portion of the boundary line would be 5'.85 less than at mound 1, hence:

N 25° 59'.07 E.

[As an approximate check upon the bearing of the line at the "Mouth," we have the following value as dependent upon two sets of solar-azimuth observations, with 4 inch theodolite, at station Daniels, viz: N 26° 00'.0 E.]

#### LATITUDES AND LONGITUDES.

Starting with the geodetic latitude and longitude of triangulation station "Sampson" as given on p. 117 and knowing the distance and bearing of the initial point of the line from "Sampson," and likewise knowing the distance and bearing of middle of mouth from mound 1 as above given, we get the following *geodetic* latitudes and longitudes:

	Latitude.	Longitude.
Initial Point <sup>1</sup> (Mound 1)	39° 43' 22"	78° 54' 50"
"Middle of Mouth"	39 28 50	79 04 01

NOTE.—The foregoing report gives abundant evidence of the very effective and valuable assistance rendered by Surveyors Beali and Brown. I desire to express here my warm appreciation of the zeal and enthusiasm shown by them and in fact by all assisting in the work. The successful issue of the survey and the expedition with which it was accomplished under most adverse circumstances are in a very large degree due to my associates.

L. A. BAUER.

OFFICE OF  
MARYLAND GEOLOGICAL SURVEY,  
Baltimore, April 4, 1903.

<sup>1</sup> This point being on the Mason and Dixon line, we have a check upon the latitude above given from the *astronomical* determinations made by Mr. C. H. Sinclair, assistant in the Coast and Geodetic Survey, in 1883, at "Maryland Corner" (Michler Monument, on the Mason and Dixon line), who obtained 39° 43' 18.0". The difference between this value and the one given above may be partly due to local deflections of the plumb line and partly due to deviations of the state boundary from a true east and west line.

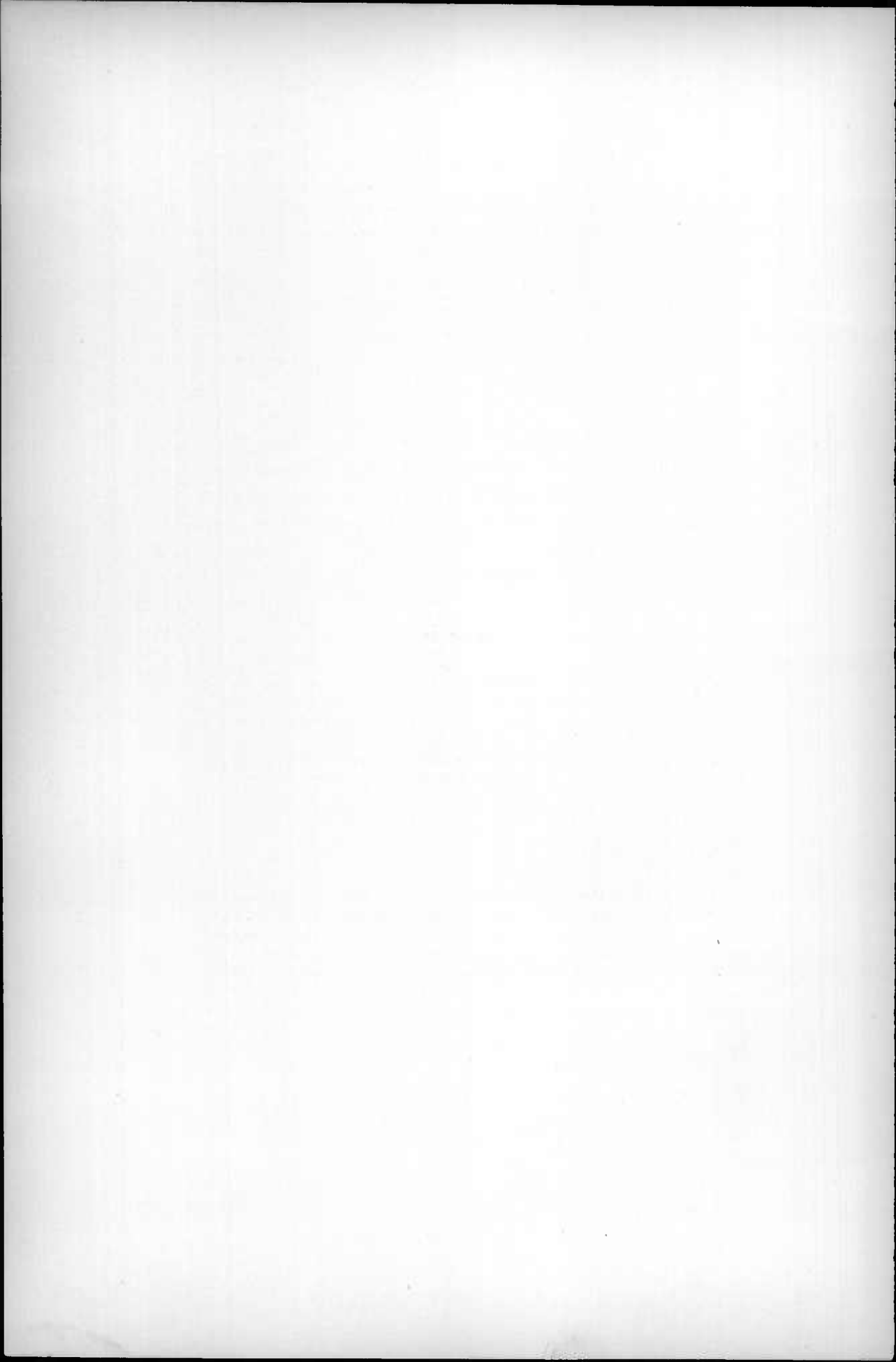

PART III

THIRD REPORT ON THE HIGHWAYS OF  
MARYLAND

BY

A. N. JOHNSON

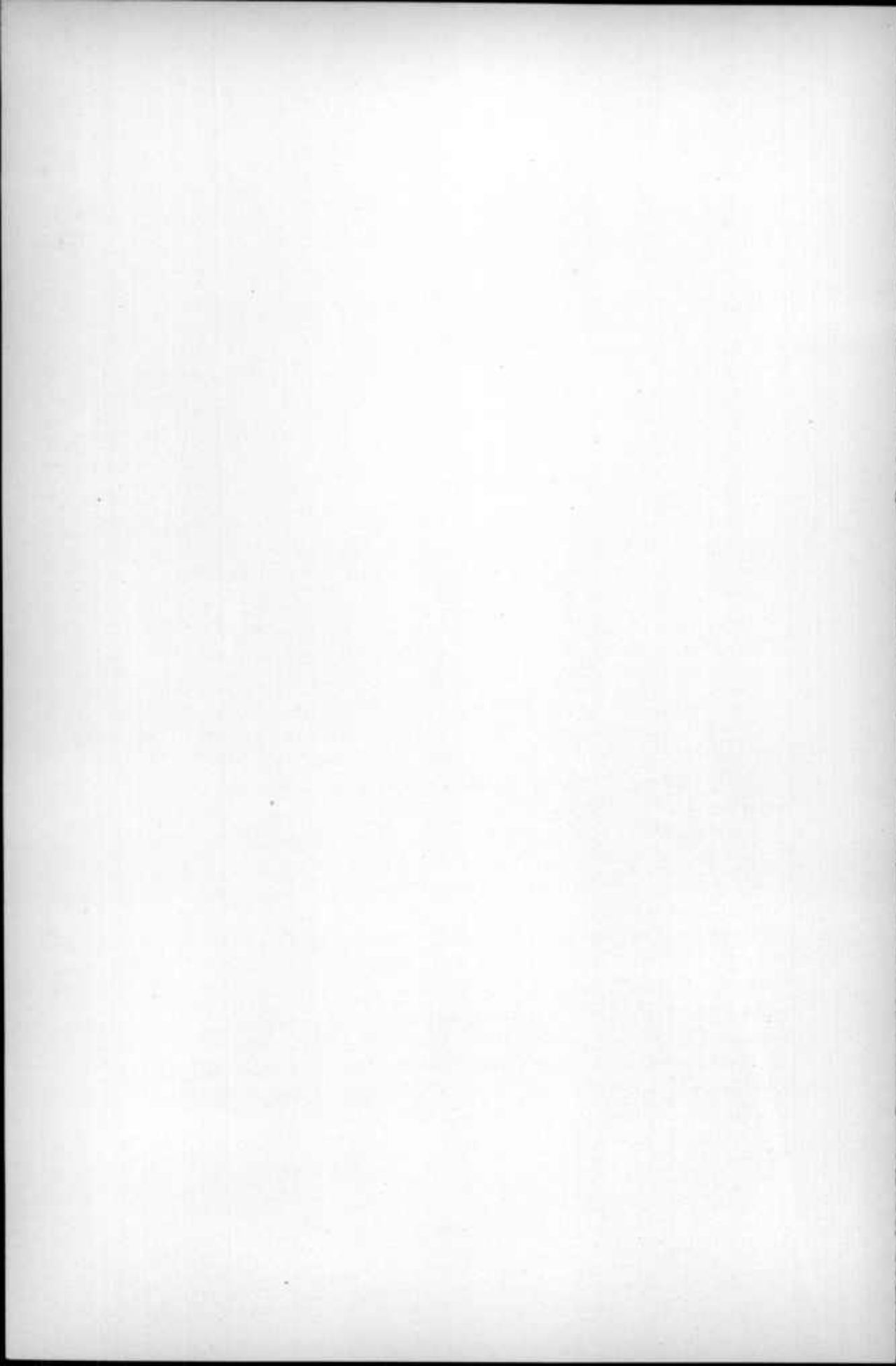



# THIRD REPORT ON THE HIGHWAYS OF MARYLAND

BY

A. N. JOHNSON

---

## INTRODUCTION.

The general method of spending the money raised for roadwork in the different counties of the State has not undergone any radical change during the time the State Geological Survey has been making special investigations of this subject; yet very marked and gratifying progress has been made in many of the counties of the State towards securing better returns for the money annually spent upon the roads.

In all cases where counties have set aside a special appropriation for permanent road improvement much satisfaction has been expressed and scarcely any one can be found who would care to have the road return to its former condition. Enough work of this character has come directly under the observation, and in many cases under the control, of the State Geological Survey to demonstrate fully the great improvement that it is possible to make in every county, no matter how small its road-levy, if the present system of allotting the money raised for roads be radically changed. Everyone who has given this question even slight consideration recognizes that the subservience of road-mending to politics is the chief obstacle at present to the economic expenditure of the road-tax in all the counties of the State. This fact was well brought out by the statement of a farmer that in his county 'they mixed politics and large rocks and had no good roads.' The elimination of political influence from the disbursement of the road money, is, perhaps, too much of a reform to expect, but it is not too much to hope that at no distant time it will be found to be good politics to make good roads.

The growth of the movement in the State towards securing better results from the road-tax is shown by the changes, made and proposed, in the road-laws of different counties and by the various meetings where this question has been discussed. The changes in the road-laws of Baltimore and Prince George's counties, made in 1900, have already been noted in the Second Report on the Highways of Maryland.

The grand jury of Allegany county in January, 1902, took up the question of road improvement and at its request the Highway Engineer of the Geological Survey attended one of its sessions to suggest a draft for a new road-law for Allegany county. The essential feature of this proposed law was to appoint a road superintendent the year round, who should have complete charge of all details of the county's road-work. In February the same question was taken up by a number of citizens of Garrett county, who consulted with the Highway Engineer concerning a new road-law. No essential change, however, in the road-law of either county was made.

In March, 1902, a meeting was held by citizens of Cecil county at Elkton to discuss and formulate plans for road improvement in the county, and, partly as an outgrowth of the interest there aroused, the County Commissioners set aside, in 1903, \$11,000 for permanent road improvement. Other meetings attended by the Highway Engineer of the Survey have been held in different counties for the purpose of considering either general or special improvements to the roads. Such meetings were held by the Neighborhood Improvement Club at Govanstown, by the Vansville Farmer's Club of Prince George's county, by the Mayor and City Council of Frederick at Baltimore, by the town commissioners of Leonardtown, St. Mary's county, by the residents of Kent and Queen Anne's county, by the Road Convention at Cumberland, by the Deer Creek Farmer's Club at Belair, Harford county, by the Sixth District Road League at Rising Sun, Cecil county and by the Third District Road League at Elkton, Cecil county. In every instance the subject under discussion was the improvement of the roads in some particular neighborhood; and at many of the meetings, plans were formulated for carrying on the improvement of some special piece of road, towards which,

in many cases, private subscriptions had been made. Besides these more or less formal meetings many informal gatherings have taken place for the same purpose. A study of the reports on the Highways of Maryland will show that nearly all of the work done either wholly or in part under the guidance of the Geological Survey has, with one or two exceptions, been paid for out of the regular road-tax levy. This has necessarily been so because, with the exception of the Woolsey bequest in Harford county, there have been no large sums from other sources available for road-work. The Geological Survey has accordingly strongly advocated special allotments from the road money for comparatively small sections of road. This method of working with the county road money has been carried on to a marked degree in Howard county for the past three or four years, during which time about \$7500 has been spent on certain bad sections of some of the main county roads. The larger part of this money has been applied to securing better grades and proper drainage for the roads; in general they have been covered with such broken stone as could be obtained cheaply in the neighborhood; and this will serve as a hard foundation for a smooth top course to be provided at some future time. A further description of the work done in Howard and other counties will be found in the pages following.

The County Commissioners in many instances have undertaken special road-work because subscriptions have been raised by persons living in the neighborhood of the improvement, and nothing can show more forcibly the desire that exists for improved roads than these voluntary subscriptions. There are still in many communities a great many persons who fight against any expenditure for public improvements. Too often it happens that these men carry considerable influence and do much harm both to themselves and their neighbors by their aggressive, short-sighted policy. Oftentimes, however, the most persistent obstructionist to a proposed improvement becomes, after the work is done, its firmest supporter.

There is no more forceful argument for road improvement than a sample of good road, and it has been the experience, not only in Maryland but elsewhere, that very frequently those who oppose building a piece of road do so through ignorance of what the results would

be, and, when once these results are made evident by a practical example, no further argument is needed. There is no doubt of the great advantage that would be gained from a system of model roads in every county in the State. Such roads have been built in a number of other states where, in many cases, the work has been much extended beyond that of merely model roads. A study of the conditions of Maryland would seem to indicate that the best results would be obtained through a moderate appropriation by the Legislature towards inaugurating a system of model roads throughout the State. The proportion of the cost of any individual road to be borne by the State should be from one-fourth to one-half, the remainder to be provided as each county might deem best. The road selected for such improvement should be the most traveled road so that the greatest number may enjoy and gain a practical acquaintance with well-constructed highways. Results accomplished by such a plan would undoubtedly be far-reaching. A practical and more effective impetus would in this way be given towards better methods of road construction than could ever be produced by all the road literature and conventions combined.

Before such work can be undertaken it will be necessary to have a considerable addition of modern road-building machinery to that now owned within the State. At least eight more steam-rollers will be needed and with each roller there should also be a good sprinkling cart. For the benefit of those counties that cannot at present afford to purchase a steam-roller the State should own a number of such machines which could be loaned to them; the expense of operating and a small charge for rental of the roller being defrayed by the counties.

#### ROAD ADMINISTRATION.

In order to secure the best results with the money appropriated by a county towards road maintenance it is essential that a proper system of administration be adopted, as would be done with any other well managed business. For the past six years the Geological Survey has made a constant study of the road-systems in the different counties of Maryland and has also kept in close touch with

the methods followed in many other States. Not only have the county methods been a subject of study, but the results have likewise been closely observed; and as a result of this study and observation the following suggestions are given as the basis for a county road law.

The form of road-law here suggested is substantially the same as that which was drawn up by the Geological Survey for Allegany county at the request of the Grand Jury, Session of January, 1902. As a whole it differs radically from the present road-law of any of the counties of the State; but a comparison of the plan with the different county road-laws will bring out the fact that its main features will be found scattered through the present county road-laws. Thus there will be found in Prince George's county a Board of Road Commissioners, while in Baltimore county there is a Roads Engineer, and many other counties also make provisions in their road-laws for a roads engineer, although Baltimore county is the only county actually employing one.

The general outline of the suggested road-law has been arranged under different headings, and its main features are briefly described and explained. Under such a law an economical and business-like management of the road funds would be possible, a result which has never been obtained so far and is, indeed, almost impossible under present conditions.

#### OUTLINE OF A SUGGESTED COUNTY ROAD LAW.

##### A DEPARTMENT OF ROADS OR BOARD OF ROAD COMMISSIONERS.

It is suggested that there be established a Department of Roads or Board of Road Commissioners to consist of three persons, one elected every year to serve three years. The Road Commissioners should have control of all moneys levied for roads and bridges, empowered to make contracts, and to sue and be sued thereon.

##### ROADS ENGINEER.

A Roads Engineer should be appointed who should hold his office during good behavior and be discharged only for incompetency

or neglect of duty. All construction and repairs to the county roads should come directly under the Roads Engineer, and he should keep an account of all expenditures connected with the work, and should make an annual report of the same to the Road Commissioners. The Roads Engineer should audit all bills and accounts for road work, and no bills should be paid unless approved by him.

#### ROAD DISTRICTS.

The county should be divided into road districts; and the roads in each district should be named and, so far as possible, the names by which they are ordinarily known in the neighborhood should be used. The road districts and the roads should be indicated on a county map on a scale large enough to enable each road and its name to be shown clearly. The roads in each district should also be classified as first class, second class, etc., according to the amount of travel each receives.

#### SUPERVISORS OR SUPERINTENDENTS.

The road district should have a Supervisor or Superintendent to be employed throughout the year and he should give all his time to the road-work in his district. Where necessary the Supervisor might be allowed one or two assistants who should also devote their entire time to road-work. The Roads Engineer should give detailed instructions to the Supervisors who should make detailed reports to him every month. In each district, and especially in those where the mileage is large, and where there is a large road-fund to be expended, a number of men should be regularly employed and should be retained year after year; they would thus become familiar with their work and would constitute a trained corps of road-menders.

#### APPROPRIATIONS.

The Road Commissioners at the beginning of the year should allot two-thirds of the total amount of the road-levy of a particular district to the exclusive use on road and bridge repairs in that district; and the remaining one-third of the road-levy should consti-

tute a general fund from which the expense of all large bridges and the special improvement of the most important roads should be met; and it might also serve as an emergency fund.

#### ACCOUNTS.

The accounts to be kept by the Roads Engineer should be itemized in every particular and all bills should show the amounts spent on each road for labor and material respectively. These bills should be made out by the Supervisor in whose district the work has been done and certified to by him, and, before they are paid by the Road Commissioners, they should be approved by the Roads Engineer after he has satisfied himself that they are correct, and that the work has been properly done. Wherever work is done by contract the direction of the work should be under the Roads Engineer and no money should be paid on such contracts without a certificate from the Roads Engineer that the work in question has been done according to the specifications. The Road Commissioners should make yearly reports, giving in detail all road expenditures, such as the amounts paid for labor and material respectively, and showing the nature and quantities of the materials used. Summaries should be made of the amounts levied in each district, and the amounts spent in each district, showing, under proper headings, the amounts spent for "bridges," "general road repairs," "surfacing" (such as macadam, gravel or shell), "grading," and "opening new roads." Under each of these headings should be shown the amounts paid for labor and material respectively. The totals for the entire county should also be stated.

It is possible that the system of administration here outlined would be too expensive for those counties whose road-fund amounts to only a few thousand dollars annually. But this difficulty could be overcome if two or three neighboring counties should be formed into one large road district and the total road-taxes be administered under a system similar to that here outlined for a single county. For instance it would be entirely feasible for two or three counties together to have one Roads Engineer, and in this way each one gain the benefits which it would be impossible for these counties to have singly.

## STATISTICS.

## MILEAGE.

The mileage of the various types of roads in the State is shown in the table on page 191 of the First Report on the Highways of Maryland, 1899. This table gives the mileage of the roads in each county classified according to the nature of the road as dirt, stone, shell, etc. The miles of main roads and of toll roads are also given. In the following table the total mileage in each county has been revised to date. The changes in the mileage of the roads in the different counties from that shown in the table in the First Highway Report is largely due to the fact that better maps of many of the counties have since been prepared by the State Geological Survey so that more reliable data can be obtained at present. Some of the increased mileage is due to new roads that have been opened since 1899; the total change on this account for the whole State is estimated to be about 150 miles. Where more reliable data cannot be obtained now than in 1899 no change in the former results is given. The changes that have occurred since 1899 in the mileage of the various types of road have not been considered of sufficient importance to justify the work necessary to bring this data up to date. There has of course been an increase in the mileage of stone, shell and gravel roads which has been greater in some counties than in others, but the ratio of the mileage of such roads to the total would not be materially changed.

## ROAD MACHINERY.

In the First Highway Report, on page 260, is found a table showing the road-machinery owned by the counties in 1899. This machinery included but two steam-rollers, both owned by Baltimore county. Since that time four rollers have been purchased, making a total of six, which are distributed as follows: Allegany county, 1; Baltimore county, 3; Cecil county, 1; and Harford county, 1. In addition to the rollers owned by the counties the following cities have steam-rollers which, with the exception of those in Baltimore might be available for county work: Cumberland, 1; Baltimore, 2; Hagerstown, 1; and Westminster, 1.



A complete list of all the road-machinery in each county at present has not been obtained, but from the information at hand an estimate of the value of this machinery has been tabulated. Besides rollers this machinery includes stone-crushing outfits, road-machines, scoops, plows and smaller implements.

County.	MILEAGE OF MARYLAND ROADS.					ROAD MACHINERY.	
	Total mileage, including turnpikes.	Miles of road per sq. mile of area.	Miles of main roads.	Percentage of main roads.	Toll roads.	Estimated value of road machinery.	Steam rollers.
Allegany .....	693	1.46	107	15	...	\$ 6,000	2
Anne Arundel .....	521	1.30	96	18	...	3,360	..
Baltimore .....	1,273	2.05	170	13	154	16,000	3
Calvert .....	385	1.54	58	18	...	50	..
Caroline .....	547	1.74	60	11	...	840	..
Carroll .....	800	1.88	68	9	30	3,775	1
Cecil .....	638	1.70	91	14	...	6,750	1
Charles .....	465	1.00	100	22	...	100	..
Dorchester .....	600	0.99	109	18	...	600	..
Frederick .....	1,280	2.02	172	13	129	2,050	..
Garrett .....	940	1.38	80	9	...	1,170	..
Harford .....	830	1.97	96	11	8	5,600	1
Howard .....	448	1.79	60	13	35	2,550	..
Kent .....	427	1.36	63	15	...	1,500	..
Montgomery .....	835	1.64	120	14	37	3,400	..
Prince George's .....	892	1.86	73	8	...	900	..
Queen Anne's .....	563	1.60	70	12	...	1,500	..
St. Mary's .....	602	1.67	85	14	...	850	..
Somerset .....	464	1.27	50	11	...	350	..
Talbot .....	397	1.40	44	11	...	1,300	..
Washington .....	799	1.84	137	17	104	1,050	1
Wicomico .....	772	2.09	54	7	...	500	..
Worcester .....	832	1.75	58	7	...	810	..
State .....	15,953	1.62	2,021	13	497	\$61,005	9

SUMMARY OF COUNTY ROAD EXPENDITURES.

The following table was made up from reports received from the County Commissioners' offices and from printed lists of county expenditures as given in the county papers. It was necessary in some instances to seek information from other sources than the County Commissioners' offices, as some of them made no reply to numerous requests for this data. The expenditures for the years 1899, 1900

and 1901 were given in the Second Highway Report on pages 160 to 162, and are repeated here. As far as possible figures that were lacking then have been supplied and errors, where discovered, have been corrected. As already stated in the Second Highway Report it is impossible to subdivide the road-expenditures under different headings for many of the counties, owing to the incomplete systems of keeping the accounts that prevail in some of the county offices.

TABLE OF ROAD EXPENDITURES 1899-1903.

County.	Total amount spent for Roads and Bridges.	Amount spent for Bridges.	Amount spent for New Roads.	Amount spent for Permanent Improvement as stone, shell or gravel.	Amount spent for Repairs.
Allegany,	1899.....	\$6,081.87	\$1,500.00	\$5,000.00	\$20,472.76
	1900.....	9,041.39	2,400.00	25,000.00	28,451.20
	1901.....	4,800.00	6,700.00	25,000.00	28,685.27
	1902.....	5,000.00	5,800.00	10,000.00	14,550.21
1903.....	10,000.00	2,000.00	15,000.00	28,619.39	
Anne Arundel,	1899.....	8,654.93	*	*	41,138.91
	1900.....	4,985.00	*	*	40,702.59
	1901.....	1,621.92	*	*	39,488.17
	1902.....	6,442.00	*	*	42,588.87
1903.....	1,958.19†	*	*	9,002.19†	
Baltimore,	1899.....	*	*	*	*
	1900.....	*	*	*	f*
	1901.....	§	§	§	§
	1902.....	§	§	§	§
1903.....	180,000.00‡	§	§	§	
Calvert,	1899.....	377.70	.....	.....	4,000.00
	1900.....	975.00	30.00	525.00	4,295.00
	1901.....	425.00	.....	300.00	4,570.00
	1902.....	*	.....	1,000.00	4,000.00
1903.....	600.00	.....	1,000.00	4,000.00	
Caroline,	1899.....	*	*	*	*
	1900.....	*	*	*	*
	1901.....	*	*	*	*
	1902.....	*	*	*	*
1903.....	200.00	200.00	*	*	
Carroll,	1899.....	8,055.60	277.10	.....	18,242.23
	1900.....	2,668.31	192.55	.....	17,141.82
	1901.....	1,436.16	54.00	.....	18,597.16
	1902.....	2,698.93	50.00	.....	13,977.31
1903.....	1,408.95	98.00	.....	16,663.83	

\* Not reported. † From July 1, 1903 to September 15, 1903. ‡ See report of County Roads Engineer. § Estimated by County Officials.

TABLE OF ROAD EXPENDITURES 1899-1903. — Continued.

County.	Total amount spent on Roads and Bridges.	Amount spent for Bridges.	Amount spent for New Roads.	Amount spent for Improvement as stone, shell or gravel.	Amount spent for Repairs.
Cecil,	1899.....	\$28,713.57	*	*	\$18,115.47
	1900.....	34,748.75	2,433.32	*	32,315.44
	1901.....	22,942.46	199.50	*	22,742.96
	1902.....	46,610.69	13,155.71	*	33,454.98
1903.....	*	*	*	*	*
Charles,	1899.....	11,500.00	1,100.00	*	7,900.00
	1900.....	10,000.00	.....	*	8,500.00
	1901.....	8,000.00	900.00	1,500.00	7,100.00
	1902.....	*	*	.....	*
1903.....	*	*	*	*	*
Dorchester,	1899.....	16,000.00	2,678.46	*	8,321.54
	1900.....	25,400.98	10,333.18†	*	10,067.80
	1901.....	15,733.39	3,051.85	*	12,681.54
	1902.....	23,652.17	3,250.21	*	20,401.78
1903.....					
Frederick,	1899.....	33,512.17	4,166.05	4,518.82	23,327.30
	1900.....	40,850.36	12,957.25	2,254.44	23,638.67
	1901.....	37,200.00†	8,000.00†	1,200.00†	26,500.00†
	1902.....	48,987.20	20,356.65	1,251.51	26,379.04‡
1903.....					
Garrett,	1899.....	12,280.59	1,493.50	104.00	10,683.00
	1900.....	14,322.47	3,482.72	49.75	10,790.00
	1901.....	12,534.73	1,000.00	278.00	11,256.73
	1902.....	21,430.84	7,016.34	204.50	14,210.00
1903.....	21,030.63	6,564.01	117.25	14,349.37	
Harford,	1899.....	25,000.00	*	*	20,000.00
	1900.....	26,000.00	*	*	21,000.00
	1901.....	36,500.00**	*	*	18,500.00
	1902.....	34,025.00	*	*	27,700.00
1903.....	25,153.00††	*	*	21,783.00††	

\* Not reported. † Includes expenditures for Brookview Bridge, not Second Report. ‡ Fiscal year not completed. †† To September 1st.

‡ Estimated by County Officials. \*\* Includes \$13,000.00 spent on the Belair-Churchville Road, \$10,000.00 from the Woolsey bequests.

TABLE OF ROAD EXPENDITURES 1899-1903.—Continued.

County.	Total amount spent on Roads and Bridges.	Amount spent for Bridges.	Amount spent for New Roads.	Amount spent for Permanent Improvement as stone, shell or gravel.	Amount spent for Repairs.
Howard,					
1899	\$21,445.16	\$5,250.80	\$293.00	\$7,973.05	\$7,928.31
1900	24,615.05	5,145.15	1,092.20	11,867.73	7,009.97
1901	22,517.63	6,982.00	587.00	8,222.15	6,726.48
1902	19,403.44	3,944.02	.....	1,408.00	14,051.42
1903					
Kent,					
1899	30,211.32	1,988.59	785.45	840.06	26,647.22
1900	17,659.61	3,798.19	1,460.69	76.41	12,824.32
1901	18,756.60	4,425.04	669.37	946.86	12,715.33
1902	38,183.84	7,929.13	*	*	30,254.71
1903					
Montgomery,					
1899	25,472.21	5,987.21	1,435.00	6,700.00	11,350.00
1900	25,121.16	4,335.66	2,332.50	6,700.00	11,750.00
1901	26,236.71	6,976.71	760.00	6,800.00	11,700.00
1902	35,195.81	8,780.90	1,030.20	11,921.15	13,463.56
1903	30,672.16	7,040.52	290.00	10,646.41	12,695.23
Prince George's,					
1899	19,000.00¶	*	*	*	*
1900	23,285.00	5,400.00	*	4,385.00	13,500.00
1901	30,021.00	7,100.00	*	5,721.00	17,200.00
1902	30,191.22	*	*	5,051.11	25,140.11
1903					
Queen Anne's,					
1899	13,301.03	4,055.59	386.95	*	8,860.49
1900	11,364.62	3,741.76	436.37	.....	7,186.49
1901	12,000.00†	4,000.00†	300.00†	.....	7,700.00
1902	16,510.89	2,912.34	27.00	2,943.20	10,628.35
1903	17,850.03	4,609.24	500.00	3,521.12	9,419.67
St. Mary's,					
1899	5,250.00¶	*	*	*	*
1900	5,250.00¶	*	*	*	*
1901	5,250.00¶	*	*	*	*
1902	6,400.00	*	*	*	6,400.00
1903	6,500.00	400.00	150.00	.....	5,950.00

\* Not reported, || Fiscal year not completed, ‡ Estimated by County Officials.

¶ Not reported by County Commissioners.

TABLE OF ROAD EXPENDITURES 1899-1903.—Concluded.

County.	Total amount spent on Roads and Bridges.	Amount spent for Bridges.	Amount spent for New Roads.	Amount spent for Permanent Improvement as stone, shell or gravel.	Amount spent for Repairs.
Somerset,	1899.....	\$11,071.04	.....	\$3,474.67	\$4,696.03
	1900.....	10,301.05	.....	2,059.90	6,081.15
	1901.....	10,430.21	1,880.91	.....	6,712.05
	1902.....	9,222.70	1,818.76	.....	5,492.92
1903.....	8,092.36	1,982.09	.....	1,670.33	4,439.94
Talbot,	1899.....	16,855.08	\$29.50	*	10,456.08
	1900.....	10,058.60	290.34	*	7,587.61
	1901.....	11,862.76	.....	*	9,201.61
	1902.....	13,258.06	2,769.86		10,488.20
Washington,	1899.....	18,879.45	6,332.67	469.00	12,077.78
	1900.....	18,433.32	4,802.18	407.00	13,234.14
	1901.....	16,670.23	1,845.57	1,406.82	13,417.84
	1902.....	19,858.52	4,775.71	1,979.70	13,103.11
1903.....	20,798.21	4,856.75	734.80	.....	15,206.66
Wicomico,	1899.....	*	*	*	*
	1900.....	7,279.11	876.98	851.50	5,550.63
	1901.....	5,644.51	278.32	91.25	5,274.94
	1902.....	10,251.65	487.79	1,642.53	8,121.33
1903.....	3,951.74	4.53	1,356.25	.....	2,590.96
Worcester,	1899.....	3,500.00	*	.....	*
	1900.....	6,500.00	*	.....	*
	1901.....	7,000.00	*	500.00	*
	1902.....	10,000.00	*	.....	*
1903.....	15,000.00	*	.....	.....	*
State,	1899.....	590,980.60 <sup>1</sup>	**	**	**
	1900.....	613,400.16	**	**	**
	1901.....	588,778.69 <sup>2</sup>	**	**	**
	1902.....	679,815.41 <sup>3</sup>	**	**	**
1903.....	650,000.00 <sup>4</sup>	**	**	**	**

\* Not reported.    † Fiscal year not completed.    §§ July 1st, 1902, to September 15th, 1903.    \*\* Not estimated.  
<sup>1</sup> Lacks Wicomico and estimates Prince George's and St. Mary's.    ‡ Estimates Frederick.    § Lacks Charles.    ¶ Approximate estimate.

## OPERATIONS DURING 1902 AND 1903.

The work of the Geological Survey in the past two years has been along the general lines followed in 1900 and 1901, and naturally divides itself under two heads, field work and laboratory work. The scope of both has been much extended during this time owing to the constantly increasing interest in the highway work of the Geological Survey as it has become more widely known in the State. In the Second Report on the Highways of Maryland, issued in February, 1902, is an account of the operations of the Geological Survey showing the results obtained in the testing laboratory and the field work done in connection with road improvement in different counties and outlining in detail the methods followed. These have not been changed materially.

When the Second Report was published, field work had been done in eight counties; Anne Arundel, Baltimore, Carroll, Frederick, Harford, Howard, Prince George's and Talbot. Since then assistance in road-work has been requested from Allegany, Baltimore, Cecil, Garrett, Harford, Howard, Montgomery, Prince George's, Queen Anne's and St. Mary's counties. A personal examination of different roads in these counties has been made by the Highway Engineer of the Survey either at the request of County Commissioners or other organizations interested in public road improvement, and, where necessary, detailed plans and estimates of the cost were prepared so that it was possible to undertake the various improvements in a business-like way.

Every effort has been made, as in previous years, to bring to the notice of the different Boards of County Commissioners and the people in the State the opportunities for aid in practical road-making which the Geological Survey offers. Through the interest in this work taken by the newspapers throughout the State the people generally have become acquainted with the facilities afforded them by the Geological Survey. In addition, a number of public meetings, held for the purpose of advancing the good roads movement, were attended by the Highway Engineer; and many of the Boards of County Commissioners were visited by him.

## FIELD WORK.

A request for either an examination or survey has been received for the following roads during 1902 and 1903: Bedford road and National road in Allegany county; Eastern avenue, Hamilton avenue, Seminary avenue, Garrison Forest road, Green Spring avenue and Stevenson Station road in Baltimore county; Rising Sun-Farming-ton and Elkton-Blue Ball roads in Cecil county; Churchville-Havre de Grace road, Forest Hill road, Fallston road and Edgewood road in Harford county; Hollofield road, Upper Sykesville road, Washington-Baltimore road, Hood's Mill road, Tobacco House Hill road and River road in Howard county; Oakland-Mt. Lake Park road in Garrett county; Dickerson road in Montgomery county; Chesapeake Junction road, T B road, Riggs road, Washington-Baltimore road and Central avenue in Prince George's county and Centerville-Chestertown road in Queen Anne's county. In addition estimates of the costs were made for the improvement of streets in Hyattsville, Prince George's county, Leonardtown, St. Mary's county and Tuxedo Park, Baltimore county. Under the head of "Special Road Improvement" on pages 162-186 will be found in detail a description of the work done on each of the above-named roads. Wherever the work was to be done by contract, specifications have been furnished to govern the construction.

Work on the roads should be pushed to completion as early in the season as possible. In some cases it has happened that work, for which the Geological Survey had made plans and specifications, was begun so late in the season that it was necessary to leave the road in a half-finished state through the winter. As a result the people in the vicinity of the road were obliged to put up with conditions far worse than those it was intended to improve. All road-work requiring grading, or seriously disturbing the existing road-bed should be begun early enough in the season to be finished before the first of November.

In order to have all such work begun early during the present year the following letter was mailed to all the boards of County Commissioners last February:



February 13, 1903.

*Board of County Commissioners, ——— County, Md.*

GENTLEMEN:—For the past few years the Highway Division of the Maryland Geological Survey has afforded the officials of the counties of the State material assistance in the improvement of the public roads. Estimates of cost, plans and specifications for improvements have been drawn up for more than half of the counties.

This work has steadily increased so that during the past season it was necessary to delay some of the road construction until late in the season. This would not have occurred if the various Boards of Commissioners had sent their requests for examinations, surveys, estimates, etc., early in the season, so that everything could be ready for construction in time to finish the work before winter.

The spring is the best time to begin road-work and in order for everything to be ready it is necessary that the surveys be made just as soon as the weather permits. Your board, therefore, is urged to communicate at as early a date as possible any proposed improvements about which you desire the aid of this office. If this is not done it may be found that, owing to previous requests received from other counties, it will be necessary to delay your work so as to seriously interfere with its completion before the beginning of another winter.

All assistance furnished by the Highway Division of the Maryland Geological Survey is free of any charge to the counties save actual field expenses while making a survey. Usually this cost does not exceed \$10 per mile of road.

Respectfully yours,

(Signed)

A. N. JOHNSON, *Highway Engineer.*

## SPECIFICATIONS.

In order to give a better idea of the methods to be followed in road improvement the Geological Survey has had printed a complete form of contract and specifications for building macadam roads. Copies of these specifications were sent to the offices of all the County Commissioners and have been given to a number of other persons interested in road construction. It is hoped that they will serve as a guide for carrying on work whether done by contract or otherwise. These specifications are reprinted on pages 203-218. It is believed that they are well adapted to the requirements in Maryland under present conditions.

One basis of payment is the number of square yards of finished road-surface; provision is made at the same time for roads of various thicknesses so that a contractor can make his bid accordingly. Another basis for payment is the number of tons or cubic yards of material

which are used to make the road-surface. Both of these methods for payment are widely used and in both cases difficulties arise. Work done under either system requires the almost constant attention of a skilled and trustworthy inspector who will see that the proper thickness is made in the one instance or that the number of loads of stone going on the road is properly distributed and correctly recorded in the other. Work has been done in the State under each method, and more satisfactory results have been secured by payment by the square yard.

A number of roads in the State have been built under these specifications and they seem to meet satisfactorily the conditions that are ordinarily encountered. It is usually more satisfactory and economical for a county to do work by contract with responsible contractors, at prices in which there is a fair profit, than for the county officials to undertake it. Some work has been done by the counties at reasonable figures, but this is the exception rather than the rule.

#### SPECIAL ROAD IMPROVEMENT.

##### ALLEGANY COUNTY.

At the request of the Grand Jury of Allegany county, at the January Session, 1902, the Highway Engineer of the Survey attended one of its meetings to suggest an outline of a county road-law. The suggested plan, which is found in full on page 149, had for its main feature the establishment of a county highway department to be under the immediate charge of an engineer upon whom would rest the responsibility for the proper care of the roads throughout the county. Recommendations were made by the Grand Jury for a change in the county's road-law, and a bill for this purpose was introduced in the Legislature, but was not passed. Public interest, however, was aroused at this time which has been productive of very substantial results.

##### NATIONAL ROAD.

Early in the spring of 1902 the County Commissioners appropriated \$5000 to be expended for a model road and requested the Highway Division to prepare plans and estimates for the work.

Two roads were selected, a portion of the National Turnpike about midway between Cumberland and Frostburg, and the Bedford road which runs north from Cumberland. This office co-operated with the Bureau of Road Inquiries, Washington, D. C., under whose charge the construction was carried on.

The portion of the National road selected had in some places grades as high as 10 per cent and for a distance of three-quarters of a mile averaged between seven and eight per cent. Owing to the location of the car tracks at one side of the road the Commissioners decided not to make any change in the grade of the road. The old road-bed was firm but had become very rough. It was loosened and rolled and low places were filled up with shale, which could be obtained near at hand. The shale was also used to form the shoulders. Limestone, obtained from the County's quarry on the road to Barrelville, was shipped by rail close to the work and was used for the new surface of the road. A ten-ton steam-roller which was afterwards purchased by the county was employed for rolling. About two-thirds of a mile of road was resurfaced. As the cost of this work, together with the amount spent on the crushing plant, exhausted the funds at hand nothing was done on the Bedford road at that time.

The work on the National road was done by day labor under the direction of Charles T. Harrison, Road Expert of the Office of Road Inquiries, Washington, D. C.

The following data were compiled from the surveys of the road, from the records of the County Commissioner's Office, and from the report of Mr. Harrison. The cost of the road as here given does not include the amounts expended by the County Commissioners for additions and permanent repairs to the crushing plant, but all repairs and supplies for the machinery incidental to the work are included as is also the sum of \$75.00 which was paid for a railroad siding.

Length of road resurfaced .....	3328 feet
Width of macadam .....	13 feet
Width of shoulder .....	5 feet
Square yards of macadam laid.....	4807

*Cost.*

Quarrying and crushing stone .....	\$ 976.64
Freight, including siding .....	752.27
Shaping road, hauling, spreading stone and forming shoulders .....	1935.97
Coal, oil, waste, etc .....	84.14
	<hr/>
Total Cost .....	\$3749.02
Cost per mile .....	5948.80

About 2300 cubic yards of shale were used to make shoulders and to fill depressions. No account was kept of the cost of this part of the work, but estimating the cost of excavation of the shale at 30 cents per cubic yard, it would be about \$690.00. If this amount is subtracted from the total it makes the cost for the macadam construction proper \$3059.02, or about 63½ cents per square yard. This is much higher than this class of work would ordinarily be expected to cost as a comparison with the prices obtained in Baltimore, Harford and Cecil counties will show. But under the conditions imposed by the County Commissioners, that the crushed stone should come from the County's quarry, and that county labor be employed by the day, the cost is as low as is consistent with good work.

## BEDFORD ROAD.

In 1903 the County Commissioners took up the improvement of the Bedford road and at their request the Highway Engineer inspected a number of quarry sites and made tests on materials from various localities. There was excellent material to be had at a number of places near the road, but the Commissioners decided to use limestone from the County quarry on the Barrelville road. The work was done by one of the county Supervisors with day labor but not under the direction of the Geological Survey. The costs of various items as given by the County Commissioners were as follows:

Length of road .....	2700 feet.
Crushed limestone, f. o. b. crusher..\$	0.433 per ton.
Freight on crushed stone.....	0.296 per ton.
Hauling crushed stone .....	0.58 per ton.
Spreading, rolling, sprinkling and in- cidentals .....	0.23 per ton.
	<hr/>
Total cost of crushed stone in road.	1.54 per ton.
Native stone, for foundation.....	0.33 per cubic yard.
Total cost of 2700 feet of road.....	\$2240.60
Cost per mile (about 12 feet wide).	4381.87

## BALTIMORE COUNTY.

The progress of good roads in Baltimore county during the past two years has been especially marked. Under the skillful direction of its Roads Engineer, Mr. W. W. Crosby, many sections of roads have been constructed according to modern methods and greater attention has been paid to proper methods of road maintenance and, so far as possible, permanent structures are replacing the old wooden bridges. The assistance of the Highway Division of the State Geological Survey has been availed of by the County's Roads Engineer for whom plans and specifications for the improvement of a number of the roads in the county have been made.

The work done in this county in co-operation with the County Roads Engineer includes the making of surveys, plans and estimates for work on the following roads, the construction of which was done under the direction of the County Roads Engineer, in whose report will be found a much fuller description than is here given. The actual cost of the work is taken from the figures furnished by Mr. Crosby.

In nearly every instance the plans of the Survey were carried out with the exception of the Garrison road, where a change in the proposed grade was made because there was not enough money to lower the grade as at first laid out. The construction on the Joppa road, Eastern avenue and Hamilton avenue was done under the form of contract and specifications substantially as found on page 203.

## GARRISON ROAD.

The Garrison road was surveyed in 1901 from C. M. Stewart's gate for a distance of 2.2 miles past Garrison Church. It was at first proposed to reduce the grades on this road to 5.5 per cent at a point near the church, but as the money available was not sufficient to do this, the grades were only lowered to 10 per cent. This road was macadamized in 1902 from the railroad to the church for a distance of 6500 feet and a width of 12 feet with limestone which was obtained in the vicinity. The cost of this work for macadam 8 inches deep was \$2970 or about 30 cents per square yard.

## STEVENSON STATION ROAD.

Surveys and plans were made in November, 1902, of the road leading from Stevenson Station and extending to its intersection with the North Valley road, a distance of 0.6 of a mile. This portion was macadamized for a width of 18 feet and a depth of 9 inches. But little grading was necessary.

## HAMILTON AVENUE.

Surveys and estimates for improving Hamilton avenue 0.3 of a mile northerly from Belair road were made in February, 1903. A grade of 14 per cent was reduced to 9 per cent by a total amount of excavation of 1440 cubic yards. The work was done by contract at the following prices:

Earth excavation .....	\$ 0.35 per cubic yard.
Ledge excavation .....	0.75 per cubic yard.

## EASTERN AVENUE.

One of the most interesting pieces of road-work in the county was the improvement on Eastern avenue for which surveys, plans and estimates were made in March, 1903, from the Northern Central railroad to the North Point road, a distance of 2.35 miles. In the vicinity of this road, which lies east of Baltimore City, there is no hard road-material, so that whatever was used must be shipped by rail. This road had for many years been repaired with oyster shells which lasted scarcely one season, owing to the great amount of travel to and from Baltimore City. After carefully considering all the available material it was decided to use the slag from Sparrows Point as a foundation course and trap rock for the upper course. The slag was chosen for the foundation course principally on account of its cheapness. It was put on so as to make a layer 5 inches thick after rolling and covered with a 3-inch layer of trap rock broken to 1½-inches in size. Owing to the smoothness and firmness with which the slag could be rolled, the second course of broken stone did not settle into it as much as would have been the case with a foundation course of ordinary broken stone; at the same time the surface of the slag foundation was not too hard to make a perfect bond with the

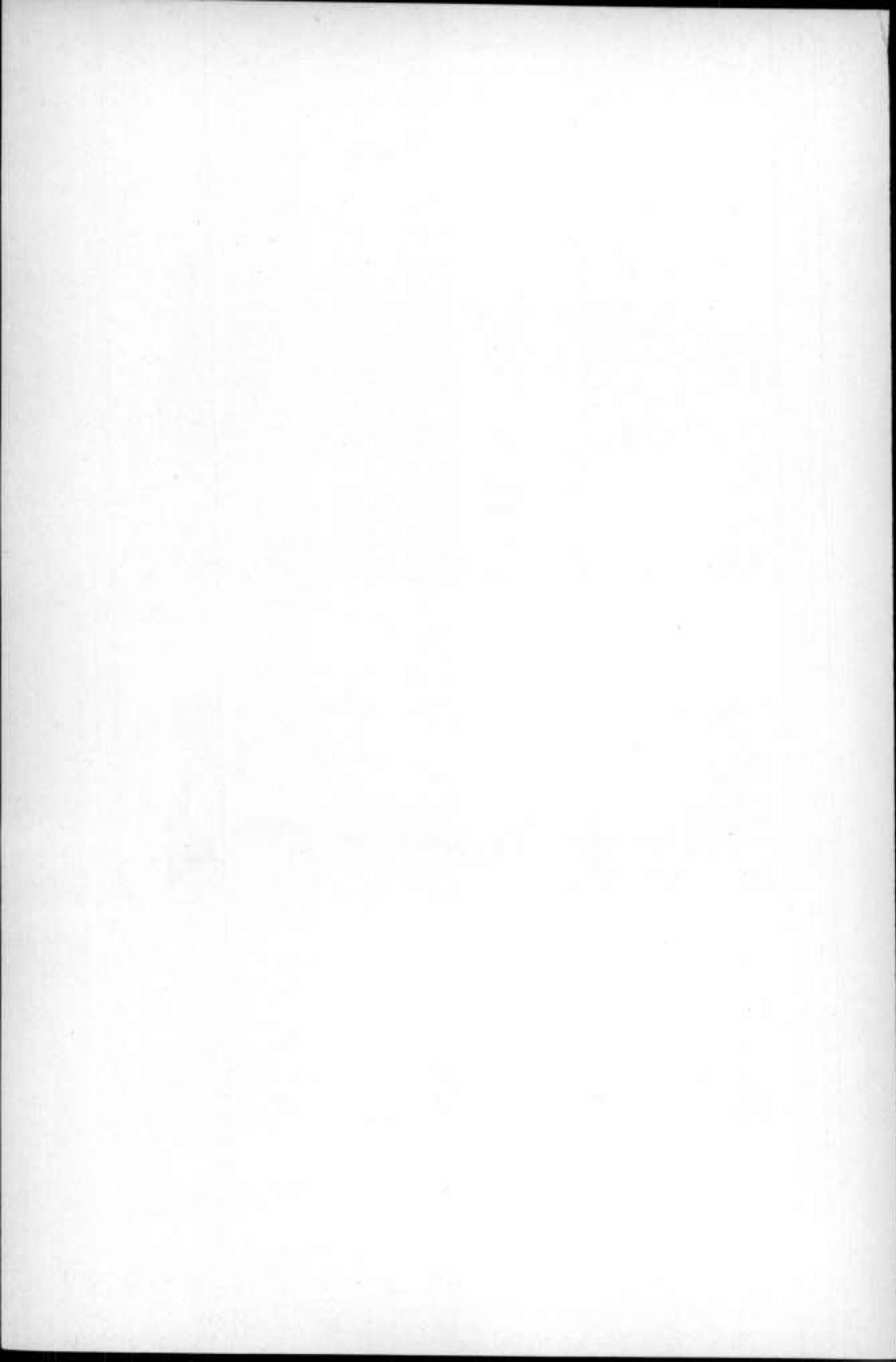

FIG. 1.—EASTERN AVENUE, BALTIMORE COUNTY.  
MACADAM ROAD WITH TRAP ROCK TOP AND SLAG FOUNDATION, SLAG SCREENINGS  
USED FOR "BINDER".



FIG. 2.—RISING SUN-FARMINGTON ROAD, CECIL COUNTY.  
MACADAM ROAD, ALL COURSES MADE OF TRAP ROCK.

ROADS BUILT UNDER PLANS AND SPECIFICATIONS OF THE MARYLAND  
GEOLOGICAL SURVEY.





upper course of stone. It was found that the trap rock screenings would cost so much, owing to the great demand for them for other purposes, that other material would have to be obtained. At first granite screenings were used, and then the finer portions of the slag were tried and proved an entire success, and at the same time were cheaper. It was also noticed that the slag screenings bonded much more readily than the stone screenings and seemed to make a firm surface to the road much more easily than the rock-dust does.



FIG. 14.—Typical cross-section of Eastern avenue, Baltimore county, showing macadam construction with slag foundation and trap-rock top course.

A typical cross-section of this road is shown in Fig. 14; and Plate XI, Fig. 1 shows a view of the road which is macadamized for a width of 15 feet and a length of 1.84 miles, and is flanked by gravel shoulders 6 feet wide. The center of the macadam is 13.5 feet from the near rail of the electric car-tracks which are at one side of the road.

The work was done by contract at the following prices:

Earth excavation .....	\$ 0.47 per cubic yard.
Gravel (borrow) .....	1.40 per cubic yard.
8-inch macadam .....	0.55 per square yard.

SEMINARY AVENUE.

Residents in the vicinity of Seminary avenue are anxious to have this road improved and many have offered to contribute a considerable proportion of the expense. At the request of the County Roads Engineer, surveys, plans, and estimates for improving this avenue between the Northern Central railroad and the Falls road, a distance of 2.2 miles, were made in May, 1903. The condition of the first mile of this road was very much better than the ordinary stone road to be found in the county.

The remainder of the road, however, had become rough and contained grades of 8 and 9 per cent for short distances. The work on this road has not yet been undertaken. The estimate for grading and resurfacing the road is as follows:

Excavation .....	5972 cubic yards.
8-inch macadam .....	1588 square yards.
6-inch macadam .....	2296 square yards.
Resurfacing .....	3333 square yards.

The total estimated cost of this work, including some large culverts, is \$6000.

PARK HEIGHTS AVENUE.

Surveys and plans for Park Heights avenue, which is one of the most frequented driving roads out of Baltimore City, were made from Wylie avenue to Old Court Lane, a distance of 3.9 miles. The plans and estimates for improving this road are at present, December, 1903, in preparation.

The cost of other modern road-work which has been under the supervision of the County Roads Engineer is here given as a guide for future estimates for this character of work, more of which has been done in Baltimore county than in all the remainder of the State.

JOPPA ROAD.

There were 5600 square yards of macadam placed on this road, which leads from Towson. The work was done under the form of contract and specifications found on page 203 at the following prices:

Earth excavation .....	\$ 0.26 per cubic yard.
Cement rubble masonry.....	4.50 per cubic yard.
Vitrified clay pipe, 10-inch.....	0.57 per foot.
Vitrified clay pipe, 15-inch.....	0.73 per foot.
6-inch macadam .....	0.31 per square yard.

(The contractor bought broken stone from the County delivered at the road for 93 cents per perch, wagon measure.)

HILLEN ROAD.

Prices paid for work on the Hillen road were as follows:

Excavating, including some ledge..	\$ 0.53 per cubic yard.
Gravel (borrow) .....	0.91 per cubic yard.
6-inch macadam .....	0.41 per square yard.
12-inch clay pipe.....	0.73 per foot.
8-inch macadam .....	0.53 per square yard.
15-inch clay pipe.....	0.83 per foot.

(The contractor bought broken stone from the County delivered at the road for 93 cents per perch, wagon measure.)

SHERWOOD BRIDGE.

The bridge which was built this year, 1903, near Sherwood Station shows the progressive character of the work that the County Roads Engineer is inaugurating. What is known as the steel concrete form of construction was adopted, which uses reinforced concrete beams instead of simple steel or wooden beams as in other forms of construction; this is the first example of its kind in the State. Steel rods are imbedded in the concrete beams to enable them to withstand heavy loads; but no steel surface is exposed to the air, so that there is practically no cost for maintenance of a bridge of this character. This bridge has a clear span of 25 feet, and has a 21-foot road-way. The cost of the bridge proper, exclusive of abutment and wing walls, was \$482.

GREEN SPRING AVENUE.

This road extends from the northerly side of Druid Hill Park to West Branch bridge in Baltimore county, a distance of about 3 miles and is maintained by the Park Commission of Baltimore City, at whose request estimates and specifications for its improvement were made by the Geological Survey in June, 1902. It was proposed at the time to surface the road with crushed stone for the first two miles and to rebuild entirely the last mile, using a telford foundation. The total estimated cost of this work was \$12,800, exclusive of grading. As this was a much larger amount than the Park Board had available for the work, it was impossible to carry out the improvement on the lines proposed.

## PARK HEIGHTS AVENUE EXTENSION.

This road has been built from the Green Spring Valley to the Garrison road in Worthington Valley, a distance of about 5 miles, under the supervision of the County Roads Engineer. It is a well-made earth road which has been properly graded and drained. The result shows the advantage of engineering skill, which is of as much importance on this class of roads as on more expensive forms of construction.

The work was done by contract at the following prices:

Earth excavation .....	\$ 0.26 per cubic yard.
Cement rubble masonry .....	5.25 per cubic yard.
Dry rubble masonry .....	3.50 per cubic yard.
Lumber in place in bridges.....	34.00 per M.
Vitrified clay pipe:	
12-inch .....	.50 per foot.
15-inch .....	.75 per foot.
18-inch .....	.90 per foot.
24-inch .....	1.25 per foot.

## CECIL COUNTY.

In March, 1902, a meeting of prominent citizens from all parts of the county was held at Elkton, to discuss road matters. It was decided at this meeting to urge upon the County Commissioners the appointment of a road engineer for the county, who should have general supervision over all the roads in the county, while in each district there should be appointed a supervisor who should have charge, under the road engineer, of road-work in his particular district. Although these recommendations have not yet been acted upon, the meeting was not without practical results, for as a more or less direct outcome of it, the County Commissioners in 1903, appropriated \$11,000 for permanent road-work in the county.

## RISING SUN-FARMINGTON ROAD.

About \$8000 of this money is to be spent on the road leading from Rising Sun to Farmington, a distance of little over 2 miles; this is one of the main thoroughfares in the county.

The work is in charge of the Sixth District Road League which

was organized for this purpose. At the request of the Road League the Highway Division of the Maryland Geological Survey made plans, estimates and specifications under which the road is to be built. The proposed construction provides for a macadam road 12 feet wide with a depth of 6 inches except in some few places; where the road has already been macadamized, about 3 inches of 1½ inch stone will be used for a top course; and on the parts of the road, where the sub-soil is not so firm, 8 inches of stone will be used. Much attention has been paid to the under drainage, which will require about 1800 feet of tile-drain. These drains extend along the road on each side of the macadam and are placed about 2½ feet below the level of the center of the road. There are no heavy grades along this stretch of road, so that but little grading is necessary; in fact the road is so nearly level at some points that the draining of the water from the road becomes a difficult matter.

The contract for the work was made on September 18, 1903, and awarded to E. Ward Brown of Port Deposit, Maryland. As much work as possible will be done this fall, but owing to the delayed delivery of the road-roller no crushed stone could be spread upon the road until October 21. Plate II, Fig. 2, shows an improved section of the road near Rising Sun.

The prices for which the work was let are as follows:

Earth excavation .....	\$ 0.30 per cubic yard.
Barrow excavation .....	0.50 per cubic yard.
Macadam construction (resurfacing)	
3 inches thick .....	0.30 per cubic yard.
Macadam construction, complete, 6	
inches thick .....	0.40 per square yard.
Macadam construction, complete, 8	
inches thick .....	0.45 per square yard.
Dry rubble masonry .....	2.50 per cubic yard.
Cement rubble masonry .....	3.00 per cubic yard.
Laying 6-inch pipe .....	0.15 per foot.
Laying 18-inch pipe .....	0.20 per foot.
Laying 24-inch pipe .....	0.20 per foot.
Laying iron pipe .....	0.25 per foot.
Extra work .....	cost, plus ten per cent.

## ELKTON-BLUE BALL ROAD.

The Third District Road League of Cecil county has in charge the improvement of the road between Elkton and Blue Ball for which there is an appropriation of about \$3000. The League did not take up this work until early in October, 1903, when an examination of the road was made by the Highway Engineer of the Maryland Geological Survey. This is one of the main roads in the county and the section over which the Third District Road League has supervision extends as far as Pleasant Hill, a distance of about  $6\frac{1}{4}$  miles. The first three miles of the road is over flat country where no grading will be required. But further on the road presents some heavy grades and the League was recommended not to improve the surface of this part of the road before the grades were lowered.

It is probable that this work will not be undertaken until next spring.

## GARRETT COUNTY.

## OAKLAND-MT. LAKE PARK ROAD.

At the request of the Mt. Lake Park Association an inspection of the roads through Mt. Lake Park was made in August, 1903, and suggestions were offered for their improvement. The Association was advised to macadamize the roads and to make the lower course out of the nearest available local material, preferably the harder variety of sandstone, and to surface this first course of native rock, which it was proposed to make about 5 inches thick, with a 3-inch layer of limestone, which it would be necessary to transport by rail. The road on which improvement should be first undertaken is the direct road between Mt. Lake Park and Oakland. It was decided for the present that there would not be enough money at hand to undertake the work, but it was hoped that later on, with the aid of a county appropriation and the co-operation of the citizens of Oakland, it would be possible to improve all of this road, which is the most traveled of any in Garrett county. Plate X, Fig. 1, shows a steam-roller at work finishing a portion of the road.

## HARFORD COUNTY.

## BELAIR-CHURCHVILLE ROAD.

This road, which was fully described in the Second Report on the Highways of Maryland on page 141, was completed in 1903. It was necessary to re-let the work, and a second contract was made with Hunt and Lackie of Belair, at the following prices:

Earth excavation .....	\$ .40 per cubic yard.
Ledge excavation .....	.90 per cubic yard.
Dry rubble masonry .....	4.00 per cubic yard.
Cement rubble masonry .....	5.00 per cubic yard.
Clay pipe, 6-inch .....	.30 per foot.
Clay pipe, 12-inch .....	.75 per foot.
Clay pipe, 15-inch .....	1.00 per foot.
Shaping road-bed .....	.075 per square yard.
Loosening and shaping stone sur- face .....	.15 per square yard.
Telford, 8-inch .....	.30 per square yard.
Broken stone .....	1.60 per cubic yard.
Extra work .....	Cost, plus 15 per cent.

Work under this contract was completed late in the fall of 1902. There still remained, however, a few stretches on this road which it was decided should be resurfaced, and this work was undertaken by the County Commissioners themselves in 1903. The cost of doing the work by this method cannot be ascertained at the present writing.

Last winter, which was very severe upon all the roads, made necessary some minor repairs which the County Commissioners were advised to have attended to immediately. This was not done, however, and a number of bad places were allowed to form. A cross-drain which had been placed according to the engineer's plans so as to carry the water by the shortest route to a natural water-course was subsequently changed by the Commissioners, so that at present the water follows along the side of the road for a considerable distance, scouring a deep ditch and endangering the road-bed itself.

## CHURCHVILLE-HAVRE DE GRACE ROAD.

Detailed plans and estimates of the road between Churchville and Havre de Grace, both by the way of Aldino and Level, were made and

completed in the spring of 1902. The total distance surveyed is 13.2 miles; the distance by each route is 8.6 miles. It was expected that this work would be undertaken with the funds available from the Woolsey bequest which provided \$15,000 for this road. It was estimated that not less than \$20,000 would be required to put the worst portions of the road in good shape, and the preliminary estimate of the cost showed that the route by the way of Level would cost about \$2800 more than that by the way of Aldino. This difference in cost is due chiefly to the greater amount of grading which would be necessary on the Level route. The Commissioners have heard many petitions for both routes but have not yet taken any action in the matter.

#### FOREST HILL ROAD.

It was proposed to improve the road from Rockspring Church through Fallston to Grafton Shops, a distance of 1.8 mile, and, at the request of the County Commissioners, surveys and plans for this work were made in November, 1902. It was proposed to macadamize this road, for which about \$1500 were to be provided by the Woolsey estate. It was found, however, that this would be insufficient and the County Commissioners decided to do nothing for the present. The residents in the vicinity of the road were very anxious for the work to be undertaken and pledged a considerable sum for this purpose.

#### FALLSTON ROAD.

Surveys and estimates for macadamizing about  $2\frac{1}{2}$  miles of the road from Fallston to Scarff P. O., were made in April, 1903. The total estimated cost of a macadam road 12 feet wide was \$7832.00. Money for this work was to come in part from the Woolsey estate, but as only \$1500 were available for this purpose, the County Commissioners have deferred taking up the matter for the present.

#### HOWARD COUNTY.

The policy pursued by the County Commissioners in 1900 and 1901 of making special appropriations to grade steep hills has been continued with much success without any increase in the road-levy



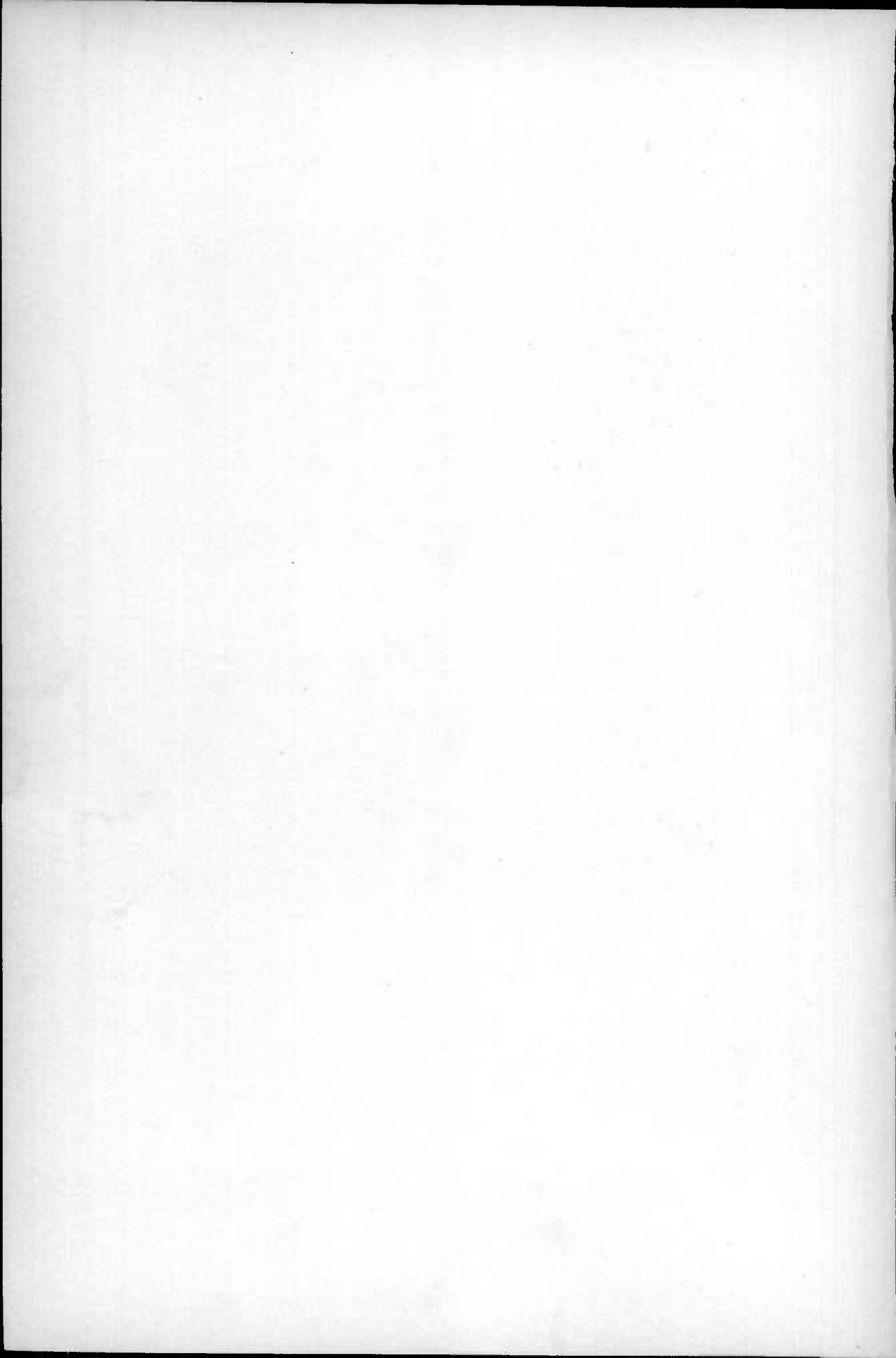

FIG. 1.—BELAIR—CHURCHVILLE ROAD, HARFORD COUNTY.  
FINISHING A MACADAM ROAD.



FIG. 2.—CHESTERTOWN—CENTERVILLE ROAD, QUEEN ANNE'S COUNTY.  
SLAG ROAD NEAR CHESTERTOWN.

ROADS BUILT UNDER PLANS AND SPECIFICATIONS OF THE MARYLAND  
GEOLOGICAL SURVEY.



The most marked improvement has been made on the Old Frederick road between Hollofield station and the Marriottsville road, a distance of about 6 miles, which included a number of very steep hills. The first of these to be graded was near the Marriottsville road and was described in the Second Highway Report on page 146.

All of this work in Howard county has been sold at public sale, the bidders underbidding one another as at an auction. At first this plan seemed satisfactory, but it was soon found that men who understood nothing at all about the cost of doing a piece of work would attend the sales and, hearing the bid of some reputable contractor, would underbid him a few dollars at a time, probably thinking that if this contractor was able to do the work for a certain sum that it surely could be done for a few dollars less. As a result a number of pieces of work were undertaken at too low a figure so that, when the Commissioners asked for bids for subsequent work, the best men were not on hand to make the bids, and the work was given out, in a number of instances, to men who were unable to carry on the construction expeditiously. While there has been the saving of a few dollars to the county treasury, the public has been oftentimes most seriously inconvenienced by unnecessary delays, and it would seem that much more satisfactory conditions would be secured if sealed bids should be asked for as is usual, even if the work should cost ten or fifteen per cent more than at present.

#### HOLLOFIELD ROAD.

The plans made in October, 1901, for the relocation of the Old Frederick road near Hollofield, were adopted by the County Commissioners, and construction was begun in May, 1902. The old location of the road was abandoned in two places, as this was much the cheaper way to obtain low grades. The plans of the new road showed grades not over 6 per cent, with the exception of 500 feet where 7 per cent was necessary. The estimated amount of grading was 5126 cubic yards. The work was divided into two sections, the first section, about 1700 feet long, was awarded to Joseph Mullen, of Ellicott City, for \$680, and the second section to William Davis, of Ellicott City, for \$1185. Owing to delays from various causes

the road was not opened to travel until 1903. This section of the road near Hollofield has not yet had any broken stone placed upon it, but this will be necessary to prevent the road-bed from washing out.

#### OLD FREDERICK ROAD, BROWN'S HILL.

The grading of the hill on the Old Frederick road just east of Brown's bridge was finished in 1903, which removed the last of the steep grades on this road between Hollofield station on the Patapasco river and the Marriottsville road. The two sections of this work near the Marriottsville road have been covered with broken stone such as was found near at hand and a reasonably smooth, hard road has been made which will answer very well as a foundation for a well-constructed macadam surface, which should be laid at some future time.

#### RIVER ROAD.

The section of the River road between Ilchester and Orange Grove was exceedingly low and in wet weather was frequently under water. The Patapasco river, along which the road runs, has been forced towards the road by the new embankment made by the railroad on the opposite side of the river. The County Commissioners were advised to relocate the road, and plans and estimates were accordingly made. The estimated amount of grading was approximately 3500 cubic yards and two 4 feet by 5 feet stone culverts were also necessary. The contract for the whole work was awarded to William Davis, of Ellicott City for \$900, who began operations late in 1902, but owing to bad weather had to leave the road in a half-finished state. Neither the old road nor the new road could be used in the spring and for a considerable time no vehicles whatever could go over the road. The work on this road was finally completed in the fall of 1903.

#### WASHINGTON AND BALTIMORE ROAD.

Plans and estimates were made at the request of the County Commissioners for grading the hill on the road between Washington and Baltimore at a point near Elkridge in Howard county. The grades were reduced from 8 per cent to 6 per cent and the excavation

amounted approximately to 1610 cubic yards. The contract was awarded in September, 1902, to W. H. Harding, of Ellieott City, for \$238. This work was not finished before winter set in and it was necessary to leave the road for some months in an unfinished condition, during which time it was nearly impassable. The work was finished in the spring of 1903.

#### UPPER SYKESVILLE ROAD.

This road runs through Howard county to Sykesville and is a portion of the road between Washington and Westminster. Near Sykesville the descent from the higher ground to the bridge across the Patapaseo river was made over three long steep hills on which the grades in many places were more than 12 per cent. Plans were made for the County Commissioners by which the grades were to be reduced to 6 and 7 per cent, and this was accomplished by relocating over a mile of the road near Sykesville, thus avoiding the first two hills. At no point of the relocation was it necessary to have grades over 6 per cent, while the third hill, it was found, could be reduced to 7 per cent without changing the present location of the road. The total estimated cost for doing the work as outlined in the plans was considerably more than the money available and the Commissioners were advised to grade only the third hill, leaving the question of relocating the road, so as to avoid the first two hills, to the future. But the residents in the neighborhood who had contributed \$500 towards the expense insisted that this money together with \$1000 which was appropriated by the County Commissioners should be expended in grading the first hill as well as the third. This plan was strongly opposed by the Highway Engineer who considered that money spent in grading the first and second hills would be thrown away, as it is practically impossible to reduce these grades to less than 10 per cent by any reasonable amount of excavation. It seemed, therefore, a most unwise thing to attempt when it was possible to secure easy grades by the relocation of the road and at a cost which would be about one-third that required to obtain grades of 10 per cent on the present road.

The advice of the Highway Engineer, however, was overruled and it was decided to do a small amount of grading on the first hill as well as to grade the third. The estimated total amount of excavation on the two hills was 5835 cubic yards and the contract was awarded to Joseph Mullen, of Ellicott City, for \$1500. The work was begun in July, 1903, and at present writing December, 1903, is nearly finished.

#### HOOD'S MILL ROAD.

The road between Cooksville on the Frederick Turnpike and Hood's Mill on the Baltimore and Ohio railroad, over which there is much hauling to the railroad, includes a number of short hills with grades between 8 and 10 per cent, but on the greater portion of the road there are no excessive grades. The surface, however, was in extremely bad condition; in those parts of the road where stone had been placed, or where the road was over bed-rock, it was very rough; in other parts the mud was at times so deep that for weeks together heavy loads could not be hauled over the road. The County Commissioners appropriated \$2000 towards improving the road and the farmers in the vicinity contributed \$1000. At the request of the County Commissioners, plans and estimates for the proper grading and draining were made and, it was advised that this should be done first and that whatever money remained over should be used for broken stone. There was great objection from many of the farmers to spending any money in reducing the grades and, strange as it may seem, some went so far as to threaten to withdraw their contributions if this were done. The Commissioners insisted, however, that the road must be graded as shown on the plans or that no money whatever would be appropriated by them towards improving it, and the conditions imposed by the County Commissioners were finally accepted.

The estimated amount of excavation was 3959 cubic yards and the contract for doing this part of the work was awarded to Albert Dorsey, of Cooksville, Howard county, for \$900. The Commissioners also made a subsequent agreement with Mr. Dorsey to spread broken stone upon the road. This part of the work, however, was not done under plans furnished by the Engineer. The work on the road was begun in July, 1903, and is at present, December, 1903, under way.

## TOBACCO HOUSE HILL ROAD.

The County Commissioners requested plans and estimates for grading Tobacco House Hill which is on the road leading easterly in Howard county from Sykesville. The grades on the present hill are as high as 12 per cent, which it was proposed to reduce as well as to straighten the road somewhat. The estimate showed that 3000 cubic yards of excavation would be required to secure a grade of 6 per cent. There would also be needed a stone-arch culvert which it was estimated would cost between \$400 and \$500. The Commissioners found, however, that there would be no money available for the work this year and did not, therefore, undertake it.

## ROCKBURN BRANCH ROAD.

This is a private road which was built by the residents in the vicinity to enable them to avoid the steep grades on Lawyer's Hill road. This road is mentioned here as being a particularly good example of a well-located road and also as showing the substantial interest that the more progressive citizens of the county take in the matter of securing better roads. The following data connected with the work was furnished by Newhall and Company of Baltimore, who were the engineers and contractors for the work. The length of the road constructed is 1.52 miles at an average grade of 3.17 per cent. The width of road-bed is 20 feet. The total amount of earth excavation was 5629 cubic yards, and of ledge excavation 3500 cubic yards. In addition, two wooden bridges of about 20 feet span were erected; a number of tile drains were laid, 150 feet of retaining wall was built and 1750 feet of guard fence was placed. The total cost was \$6186.55. During the construction much disintegrated rock was encountered which, as far as possible, was used to surface the road and, as it is designed only for light travel, principally during the dry portions of the year, this answers very well.

## MONTGOMERY COUNTY.

## DICKERSON ROAD.

The County Commissioners proposed grading what is known as Big Hill on the road between Dickerson and White's Ferry and re-



quested that the Geological Survey make the plans and estimates; this was done in April, 1903. The hill extends from the bridge at its foot for about 800 feet, the grades averaging nearly 14 per cent, the steepest portion being 23 per cent. To reduce these grades to 9 and 10 per cent it was estimated that about 1300 cubic yards of excavation would be necessary and that it would cost about \$800. If the bridge was raised 8 feet and a grade of 7 per cent established there would be about 2000 cubic yards of ledge and about 2300 cubic yards additional material to be excavated, which would cost, including the raising of the bridge, about \$2000. The Commissioners were advised, owing to the steepness of other hills on the same road not to spend so much for the present at this one point; and the 9 and 10 per cent grades were recommended. The plans were so drawn that the work done to reduce the grades to 9 and 10 per cent would not be wasted if, at any subsequent time, the grades were further lowered. No work has, however, been done under the plans furnished.

#### PRINCE GEORGE'S COUNTY.

Under the new road-law for Prince George's county, which was passed in 1900, there has been a greater opportunity for efficient results from the road money than had been the case previously; but the hopes of those interested in having better results obtained for the money expended have been only partially realized. The fault has been due partly to the law; and in large measure to its execution, which has left much to be desired. By this law the Highway Division of the Geological Survey is required to give directions for carrying on work on the roads leading from Washington, the improvement of which, it is provided, shall be paid for out of the license fund, which amounts to about \$6000 a year. This part of the road-work, therefore, has come more closely under the observation of the Geological Survey than any other in the county.

The first two years' work has already been fully outlined in the "Second Report on the Highways of Maryland," on pages 148-159. The work done in those two years did not follow the plans and suggestions given by the Geological Survey, particularly in the case of the Washington and Baltimore road, on which there was apparently



expended much more money than the improvement would seem to warrant. On the T B road somewhat better results were obtained, although some construction of extremely poor character was made here also. The Road Commissioners decided in 1901, against the advice of the Highway Engineer, to begin the improvement of a number of roads leading from Washington, thus dividing the amount available into small sums, which at best would not be as efficient a method of expenditure as if all the money had been expended upon one or two roads.

The work of the Road Commissioners with the license fund in the past two years has been as unsatisfactory as in the two years previous. This work as a whole has not been pushed with vigor. In order to avoid the trouble experienced on the Riggs road caused by leaving the road in a half-completed state through the winter, the Road Commissioners were especially urged to begin their work early in the season. In spite of this, much valuable time was lost at the beginning of each season, especially in the case of the improvements on Central avenue, which were not begun until October. At many different times the Road Commissioners have been advised to purchase a suitable road-roller but so far this has not been done and none of the roads have been rolled.

The result of the expenditure of the license fund for 1902 and 1903 is a continuation of the improvement to the T B road, which is the best of the work so far done, the grading and graveling of the Riggs road and a small amount of work on Central avenue. No work has been done on the Washington and Baltimore road during these years under the plans of the Geological Survey. With the exception of the work on the Riggs road, which was done by contract, and on Central avenue no definite figures of the cost of the improvements of any of these roads could be obtained.

#### RIGGS ROAD.

In the spring of 1902 the work on the Riggs road, which had been left in a half finished condition during the winter and which had become nearly impassable, was resumed. The contract for completing the grading was given to E. E. McChesney, of Hyattsville,

Maryland, and the contract for graveling the road to Samuel Queen, of Tacoma Park, Washington, D. C. The amount of grading was approximately 1350 cubic yards and cost \$325. The graveling covered 2600 feet of road, 15 feet wide and 12 inches deep, and cost \$485.

#### WASHINGTON AND BALTIMORE ROAD.

Surveys of this road had been completed as far as Paint Branch in 1902, and it was then proposed to grade and gravel a portion of the road, beginning at a point near the Hyattsville line and extending to Paint Branch; also to reduce the grade at a point about one-half mile from Hyattsville from 8 and 9 per cent to 5 per cent; and to change the grade on what is known as Cat Tail Hill from 7 and 8 per cent to 5 per cent; the total amount of excavation would be about 5000 cubic yards. The Commissioners were advised first to grade the hills and surface them with gravel and then to proceed to gravel the remainder of the road as far as their funds would permit.

#### T B ROAD.

This road was improved for a distance of about  $1\frac{1}{4}$  miles from the District line to a point near Silver Hill in 1900 and 1901, as described in the Second Report on the Highways of Maryland, on page 154. In 1902 the plans for reducing the grades on the north side of Henson's branch were carried out. On this slope it was impossible, even with cuts as deep as 9 and 10 feet, to get a better grade than 8 per cent, and it was necessary to extend this grade for a distance of 1300 feet. The former grades were as high as 13 per cent. On the south slope but little change in the grade was considered necessary. The road was graveled for about  $1\frac{1}{2}$  miles.

The following year, 1903, the Road Commissioners desired to extend the improvement and to reduce the grades where the road crosses Wilson's branch. Plans and estimates were accordingly made showing the grades on the north slope, or Wilson's hill, reduced from 12 per cent to 6 per cent which was extended for a distance of 1200 feet. It was necessary to make somewhat steeper grades for a short distance on the south slope, known as Middleton's hill;

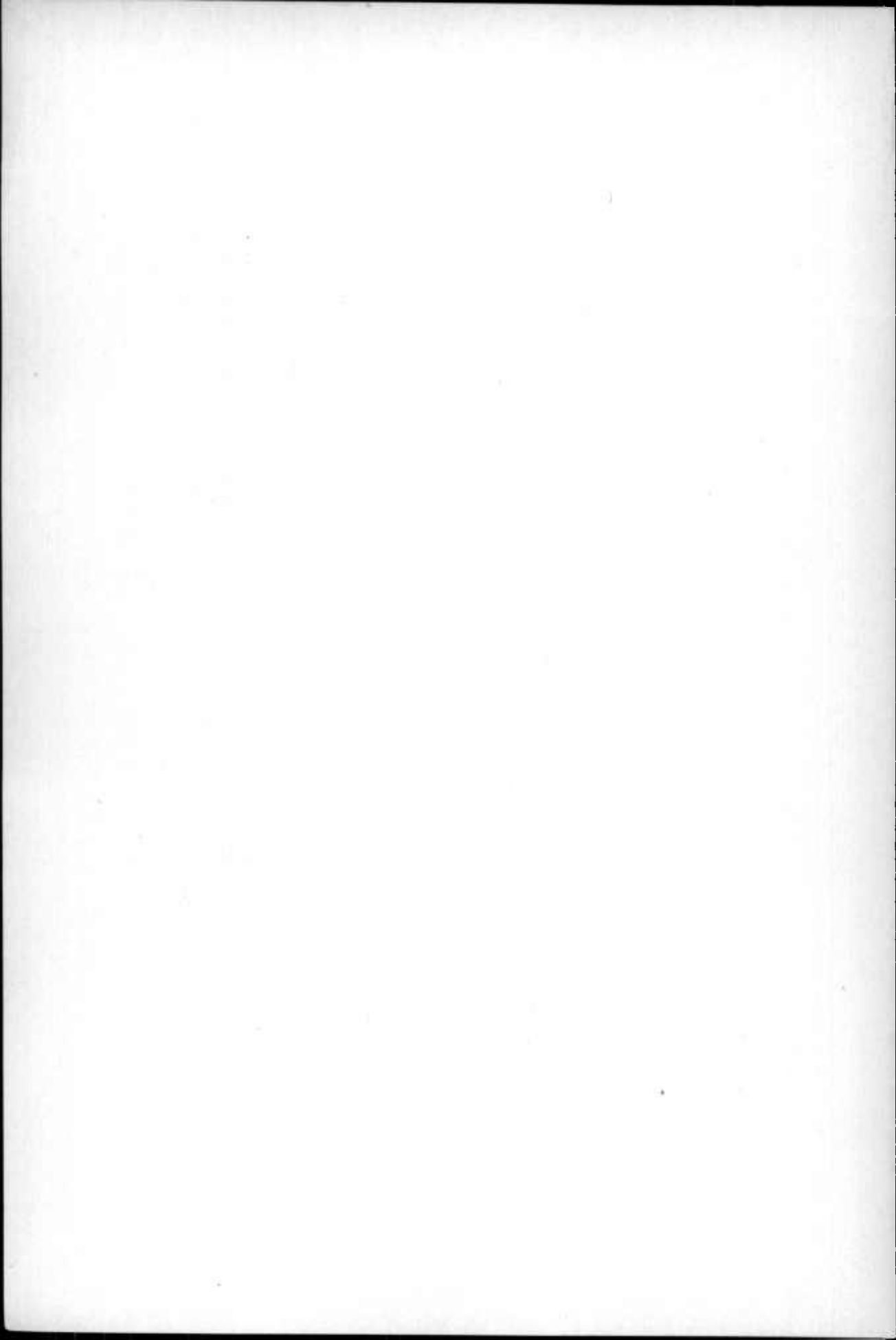

FIG. 1.—T B ROAD, PRINCE GEORGE'S COUNTY.  
DEEP CUT MADE TO REDUCE THE GRADE OF WILSON'S HILL.



FIG. 2.—T B ROAD, PRINCE GEORGE'S COUNTY.  
CONCRETE CULVERT AND EMBANKMENT AT THE FOOT OF WILSON'S HILL.

ROADS BUILT UNDER PLANS AND SPECIFICATIONS OF THE MARYLAND  
GEOLOGICAL SURVEY.



where an 8 per cent grade was used for about 400 feet and one of 6 per cent for 700 feet which brought the road to the top of the hill. All of the grading has not yet been completed. Very little work has been done on Middleton's hill, and Wilson's hill at some points has not been cut to within 2 or 3 feet of the grade as shown on the plans. The deep cut made on this hill is shown on Plate XI, Fig. 1. Plans were also prepared for a concrete culvert with a water-way 4 feet wide and 5 feet high. This culvert was built in a very satisfactory manner. The end walls rise 12 feet above stream-level and wing-walls protect both ends of the culvert; a view of the culvert is shown on Plate XI, Fig. 2. The concrete was made from the gravel and sand found in the immediate vicinity. During this year, 1903, the whole of the T B road has been regrav-eled from the District of Columbia line as far as Wilson's branch, a distance of about 6 miles. The regravelling of the sections of the road, on which work was done in other years, was made necessary by the severe weather of the past winter, which caused the clayey gravel, which had previously been put upon the road, to cut through in many places, so that it was deemed advisable to resurface all of the road with a sandy gravel. The work done upon the road in 1902 and 1903 has been under the supervision of Mr. Hardy, one of the Board of Road Commissioners, who carried on the work by day labor.

#### CENTRAL AVENUE.

Surveys and plans for the improvement of this road, beginning at the District of Columbia, were made in 1901. Nothing, however, was done until the present year, when the Road Commissioners decided to expend a portion of the license fund in grading and gravelling this road. Although everything was in readiness to take up the work early in the season it was not begun until October. In order to grade properly the hill near the District of Columbia it was necessary to extend the embankment over the line into the District, for which the consent of the District Commissioners was obtained. The grading and gravelling of this hill was the only work done on Central avenue. The grades here have been reduced from

7 and 8 per cent to 4 per cent. The cost, reported by the Road Commissioners, was \$588.10 which includes graveling about 1000 feet of road which amounted to about 1214 cubic yards.

The work on this hill led the Commissioners of the District of Columbia to improve the continuation of the road within the District, so that now there is a continuous stretch of good road from the county into the City of Washington.

#### CHESAPEAKE JUNCTION ROAD.

The Road Commissioners requested plans and estimates for a new road, which it was proposed to open near Chesapeake Junction, between what is known as the Chapel road and the Hill road, a distance of about 1.2 miles. Although some work has been done, the plans furnished by the Geological Survey have not been followed.

#### QUEEN ANNE'S COUNTY.

##### CENTERVILLE-CHESTERTOWN ROAD.

The County Commissioners of Queen Anne's county decided in the spring of 1902, to build a short section of sample road, for which purpose they set aside \$500 to pay for the material. The road selected is that connecting Centerville and Chestertown and the section of the road improved is about one mile from Chester River bridge. The people in the vicinity, both in Kent county and in Queen Anne's county, took a very active interest in the work and agreed to furnish all the labor needed. A committee with Mr. W. Irving Walker of Queen Anne's county as chairman was organized and took complete charge of the work. At the request of this committee, forwarded through the County Commissioners, plans and estimates for the work were drawn up by the Geological Survey.

The section of the road which was selected for improvement is over a heavy clay soil and is nearly level so that water stood in the ditches at the sides of the road. This part of the road was notorious for its bad condition, the mud being often so deep in the winter and spring that it was impassable. Immediately adjoining this section

of the road is a stretch of very sandy soil which becomes very soft in dry weather, making it practically impossible to drive faster than a walk. In wet weather this part of the road was much better than in the dry season, but at every season some portion of it was bad.

No other material had been used on this road except oyster shells which wore out rapidly and made a very dusty road in dry weather. The committee was advised to surface the road with slag from Sparrows Point which it was believed could be obtained at a lower cost than any other material. This was accordingly done and about 500 tons were loaded on a barge at Sparrows Point and brought to Chestertown. It was then hauled from the wharf to the road, a distance of about a mile and a half. It was decided to put the slag over the clay portion of the road.

Actual work was begun on the 29th of July, 1902, and was finished August 9. The work was done under the immediate direction of the Geological Survey and was carried on as follows: First, the road was shaped with a road-machine which also formed the shoulders at the sides. The road-bed was then rolled and slag spread for a depth of 10 inches at the center, decreasing to 7 inches at the sides, measured loose. Eleven hundred feet of road was covered with slag for a width of 15 feet, requiring 458 tons of slag, and about 45 tons of finer material was used as a binder. The slag was well watered and rolled. The roller used for the work was a 3½-ton horse-roller which was loaned by the Good Roads Machinery Company of Kennetts Square, Pennsylvania, at the request of Mr. Eldridge, Assistant Director of the Office of Road Inquiries, Washington, D. C. A heavier roller would have been much better for the work, although good results were obtained with the light roller owing to the readiness with which slag compacts. Plate X, Fig. 2 shows the finished slag road.

After more than a year's wear the road is proving entirely satisfactory and is much less worn than a shell road would have been under similar circumstances. As is the case with most country roads, the travel here follows in a single track, which must inevitably produce ruts, no matter how hard the road-surface may be. Last winter, which was unusually severe upon the roads, did not develop

any sign of weakness in the slag road and it is reported that this is the only piece of road between Centerville and Chestertown over which it was possible to go at a trot during the winter. Owing to the extraordinary difficulty encountered in getting the slag, its cost was more than twice what it ordinarily would be. Estimating the cost of the slag on board a barge at Sparrows Point at 41 cents a ton, which is the price that has since been quoted by the Steel Company, the cost of a slag road, all other items being based on the actual cost of this sample road, is as follows:

## ESTIMATED COST OF A SLAG ROAD.

Based on actual cost of sample road built in Queen Anne's county in August, 1902.

Items.	Cost per ton.
Slag, on board barge at Sparrows Point.....	\$0.41
Freight, 100 miles by barge.....	0.54
Unloading barge .....	0.12
Hauling, average distance 1½ miles .....	0.27
Spreading .....	0.07
Rolling and watering .....	0.02
Total cost of slag in place on road .....	\$1.43

## COST PER MILE 15 FEET WIDE.

Slag, 2400 tons at \$1.43 .....	\$3432.00
Shaping road-bed, 8800 sq. yds., at ½c. ....	44.00
Total cost per mile 15 feet wide .....	\$3476.00
Total cost per mile 12 feet wide .....	\$2800.00

## ST. MARY'S COUNTY.

## LEONARDTOWN SQUARE.

The Town Commissioners had under consideration the improvement of the square at Leonardtown and asked the assistance of the Geological Survey in this matter. The Highway Engineer in July, 1903, met the Town Commissioners at Leonardtown and made recommendations for draining and grading the square. These recommendations were carried out by the commissioners as far as the money at their disposal would permit. About \$300 was expended in the construction of gutters, in laying one hundred feet of 18-inch drain-pipe and in grading and shaping the street.



## LABORATORY WORK.

The laboratory work during the past two years has been confined to the study of the classes of materials mentioned in the Second Report, including various kinds of rocks, cements, bricks and other paving materials. Some new methods have been developed and so far as the limited time would permit, special investigations, which gave promise of valuable results, have been made.

The work already done in the State Geological Survey's laboratory would, it is thought, justify the extension of this branch of its work along broader lines looking to the establishment of a State laboratory where all classes of materials of construction could be tested, and standards established and compared. A laboratory of this character would be of great practical value to the cities and towns in all parts of the State. Specifications for paving and building materials could be more definitely drawn, as the means would be at hand for making the tests necessary to determine if any particular lot of material satisfied the conditions imposed.

Such a laboratory should be available to all public officials for public work without charge, whereas tests for private persons should also be permitted on payment of a nominal fee, which would prevent requests from the merely curious. This plan has been followed in the work so far done in the State Geological Survey's laboratory and the number of requests for tests that have been received gives evidence of the demand that exists of this character and fully warrants its continuance and expansion.

## TESTS OF MACADAM MATERIALS.

A number of tests of the materials used for macadamizing the roads built under the direction of the Geological Survey, and also those built by the Roads Engineer of Baltimore county have been made. The large number of tests which had already been made have proved of great value for comparison with new materials. A full description of the methods used and the results obtained from tests from nearly every variety of rock in the State is found on pages 315-327 of the First Report on the Highways of Maryland, and on pages 123-127 of the Second Report on the Highways of Maryland.

TABLE SHOWING RESULTS OF TESTS OF PAVING BRICK OBTAINED AT THE LABORATORY OF THE HIGHWAY DIVISION OF THE MARYLAND GEOLOGICAL SURVEY.

Laboratory No.	Name and where manufactured.	Color.	Per cent lost in rutler at the end of 1800 revs.	Total cross-breaking strength in lbs.	Modulus of rupture, lbs. per sq. inch.	Per cent of absorption in 48 hours.	Remarks.			Sample selected by
							Date of test.	Made for		
121	"Montello Block," Reading, Pa.....	Red.	17.6	.....	.....	.....	Dec. 21, '01.	City Engineer of Balto.	Geological Survey.	"
122	"Porter Block," New Cumberland, W. Va.....	Buf.	22.5	.....	.....	.....	"	"	"	"
123	"Guise Block," Williamsport, Pa.....	Red.	24.7	.....	.....	.....	"	"	"	"
124	"Mack Block," New Cumberland, W. Va.....	Buf.	19.5	.....	.....	.....	"	"	"	"
125	"McAvoy Block," Perkiomen, Pa.....	Red.	21.7	13,283	2758	1.0	Jan. 22, '02.	"	Manufacturer.	"
126	"McAvoy Brick," Perkiomen, Pa.....	"	24.7	18,185	4010	1.6	"	"	"	"
127	"McAvoy Repressed Grooved Block".....	"	19.0	13,612	2650	1.6	"	"	"	"
128	Malvern Clay Co., Malvern, O.....	Dk. brown.	27.7	21,450	3323	3.7	Feb. 5, '02.	"	"	"
129	Salisbury, Md.....	Light red.	45.0	.....	.....	7.0	May 6, '02.	Council of Salisbury, Md.	"	"
130	"Johnsonburg Pavers," Johnsonburg, Pa.....	Red.	26.8	.....	.....	.....	May 27, '02.	City Engineer of Balto.	"	"
131	"Johnsonburg Pavers," Johnsonburg, Pa.....	"	30.1	.....	.....	3.3	May 29, '02.	"	"	"
132	"Johnsonburg Pavers," Johnsonburg, Pa.....	"	31.4	.....	.....	.....	June 2, '02.	"	"	"
136	"Maxwell Pressed Block".....	"	22.9	.....	.....	.....	June 7, '02.	"	"	"
137	"Double Maxwell Block".....	"	22.2	.....	.....	.....	June 11, '02.	"	"	"
138	"Maxwell Block".....	"	22.8	.....	.....	.....	June 13, '02.	"	"	"
139	"Maxwell Block".....	"	22.8	.....	.....	.....	"	"	"	"
140	"Maxwell Block".....	"	29.1	.....	.....	.....	"	"	"	"
141	"Maxwell Block".....	"	26.3	.....	.....	.....	June 16, '02.	"	"	"
142	"Maxwell Block".....	Dark.	24.0	.....	.....	.....	June 17, '02.	"	"	"
143	"Maxwell Block".....	Medium.	24.8	.....	.....	.....	"	"	"	"
144	"Maxwell Block".....	Light.	25.7	.....	.....	.....	"	"	"	"
145	"Maxwell Block".....	Dark.	24.0	.....	.....	.....	"	"	"	"
147	Clearfield Clay Working Co.....	Buf.	23.9	.....	.....	.....	July 5, '02.	"	"	"

TABLE—CONT'D. RESULTS OF TESTS OF PAVING BRICK OBTAINED AT THE LABORATORY OF THE HIGHWAY DIVISION OF THE MARYLAND GEOLOGICAL SURVEY.

Laboratory No.	Name and where manufactured.	Color.	Per cent lost in rattle at the end of 1800 revs.	Total cross-breaking strength in lbs.	Modulus of rupture, lbs. per sq. inch.	Per cent of absorption in 48 hours.	Remarks.		
							Date of test.	Made for	Sample selected by
148	Clearfield Clay Working Co.....	Buff.	27.0	.....	.....	.....	July 5, '02.	City Engineer of Balto.	Manufacturer.
149	Clearfield Clay Working Co.....	"	20.0	.....	.....	.....	"	"	"
150	Clearfield Clay Working Co.....	"	22.3	.....	.....	.....	"	"	"
151	Clearfield Clay Working Co.....	"	22.2	.....	.....	.....	July 7, '02.	"	"
152	Clearfield Clay Working Co.....	"	23.7	.....	.....	.....	"	"	"
153	Clearfield Clay Working Co.....	"	27.4	.....	.....	.....	"	"	"
154	Clearfield Clay Working Co.....	"	30.1	.....	.....	.....	July 8, '02.	"	"
155	Clearfield Clay Working Co.....	"	25.8	.....	.....	.....	"	"	"
156	Clearfield Clay Working Co.....	"	22.1	.....	.....	.....	"	"	"
157	Clearfield Clay Working Co.....	"	24.5	.....	.....	.....	"	"	"
159	" Maxwell Block ".....	Red.	29.3	.....	.....	.....	July 26, '02.	"	"
160	" Maxwell Block ".....	"	35.0	.....	.....	.....	Aug. 1, '02.	"	"
161	" Maxwell Block ".....	Dark red.	26.9	.....	.....	.....	Aug. 13, '02.	"	"
162	" Metropolitan Block," Canton, O.....	Dark red.	17.2	.....	.....	.....	Oct. 7, '02.	"	"
203	" Granite Akron Block," Akron, O.....	Red.	18.4	.....	.....	.....	Aug. 1, '03.	City Engineer of Balto.	"
207	" Metropolitan Block," Canton, O.....	Dark red.	18.0	.....	.....	.....	Oct. 10, '03.	"	"
208	" Mack Block ".....	Buff.	24.2	.....	.....	.....	"	"	"
209	" Mack Block ".....	"	25.8	.....	.....	.....	"	"	"

TABLE SHOWING WEAR FOR EACH BRICK IN RATTLER TESTS.

(Bricks of the same make have like letters after the test number.)

Laboratory Number.	Make.	Percentage lost by each brick in a test.										Average.	Character of Shot.
		No. 1	No. 2	No. 3	No. 4	No. 5	No. 6	No. 7	No. 8	No. 9	No. 10		
168	A	17	19	22	23	23	23	23	24	28	30	23.3	Old cast iron.
169	A	15	15	17	21	23	25	30	32	32	40	24.8	" "
170	A	19	22	22	24	24	24	25	26	34	38	25.9	" "
171	A	16	17	20	22	22	28	29	29	29	30	24.1	" "
172	A	17	18	18	22	22	23	24	25	30	30	22.7	" "
173	B	16	17	17	17	18	18	19	19	20	..	17.8	" "
174	B	13	14	14	15	15	16	17	19	22	..	16.0	" "
175	B	13	13	14	16	16	16	16	17	22	..	15.8	" "
176	B	12	13	14	14	16	17	18	18	19	..	15.6	" "
177	B	11	14	15	16	16	17	17	19	20	..	16.0	" "
178	C	25	30	30	32	32	38	38	39	53	..	35.3	" "
179	B	19	20	20	20	21	21	24	24	26	..	21.7	Steel.
180	B	16	18	20	21	21	21	22	22	25	..	20.5	" "
181	B	16	17	18	19	19	21	23	23	24	..	20.3	" "
182	B	17	18	21	21	21	22	22	23	23	..	20.9	" "
183	B	17	18	18	18	19	19	22	22	27	..	19.9	" "
184	A	23	24	27	27	27	28	36	39	39	50	31.9	" "
185	A	26	21	24	24	25	26	29	29	34	39	27.1	" "
186	A	19	23	25	25	27	28	28	29	31	37	27.2	" "
187	A	23	23	23	23	25	27	27	28	34	34	26.7	" "
188	A	22	24	24	26	26	27	29	32	38	40	28.8	" "
191	C	32	34	37	40	40	42	60	62	71	..	42.0	" "
192	A	22	22	23	23	24	24	28	30	31	33	25.9	New cast iron.
193	B	12	14	17	21	21	22	29	30	43	..	23.2	" "
194	C	48	51	53	54	54	55	57	57	57	..	54.0	" "
195	C	34	38	39	44	45	45	46	55	..	..	43.4	" "
196	C	26	27	31	31	32	33	35	37	60	..	35.0	" "
198	A	18	19	19	21	22	22	25	32	39	42	26.0	" "
199	B	13	14	16	16	16	17	17	19	20	..	16.4	" "
200	A	16	17	19	23	24	25	30	31	31	53	26.9	" "
201	B	14	14	14	16	16	17	21	25	26	..	18.1	" "
202	A	16	19	19	20	20	23	23	24	34	36	23.1	" "
203	D	16	16	17	18	19	19	20	20	20	..	18.4	" "
204	B	14	15	16	16	16	16	17	18	18	..	16.2	" "
205	A	16	17	18	18	22	22	22	23	24	26	20.8	" "
206	B	12	13	14	15	18	20	20	20	20	..	15.8	" "
207	E	16	19	21	22	22	24	24	26	27	..	22.0	Steel.
208	F	18	18	22	22	23	24	25	26	28	36	24.2	" "
209	F	19	23	23	24	24	25	25	30	31	34	25.8	" "

## PAVING BRICK TESTS.

A full description of the details of the tests made on paving brick is to be found in the Second Report on the Highways of Maryland, pages 110-120. A table of the results of the tests made at this laboratory up to 1902 is given in the same report on pages 118-120.

RATTLER TESTS.

The results of a number of rattler tests made in 1902 and 1903 are given in the following tables. Nearly all of these tests were made at the request of the City Engineer of Baltimore. In a number of instances each brick was marked and weighed before and after the rattler test. This method of conducting the tests has proved more satisfactory as it shows the difference in uniformity between different lots of bricks and thus makes it possible to draw specifications so as to secure a more uniform product.

RATTLER TESTS WITH CAST IRON AND STEEL SHOT.

There has been made in the past two years, in addition to the regular tests, a series of tests to determine the difference between the results of rattler tests made with steel shot and with cast iron shot. Two varieties of brick, of which there were a considerable number at the laboratory, were selected. The samples of each variety consisted of bricks which had gradually accumulated from time to time as different shipments were received. The bricks selected represent one of the hardest varieties and one that is moderately soft. Fifteen tests were made of each. Five tests of each variety were made with an old charge of cast iron shot which was not changed during these tests, so that at the end of the ten tests the shot had worn nearly round. The total weight of this old shot when removed was 245 pounds, the weight at the beginning was about 270 pounds. Five tests were then made of each variety of brick with a charge of new steel shot weighing 300 pounds. A third set of five tests were made on each of the two kinds of brick with an entirely new charge of cast iron shot, the weight of this charge being 300 pounds. The results are given in the following table:

PERCENT LOST IN RATTLER TESTS WITH			
	Old Cast Iron Shot.	New Cast Iron Shot.	Chilled Steel Shot.
Soft Brick, (all of the same make.)	23.3	25.9	31.9
	24.8	26.0	27.1
	25.9	26.9	27.2
	24.1	23.1	26.7
	22.7	20.8	28.8
Average.....	24.2	24.5	28.3

## PERCENT LOST IN RATTLER TESTS WITH

	Old Cast Iron Shot.	New Cast Iron Shot.	Chilled Steel Shot.
Hard Brick, (all of the same make.)	17.8	23.2	21.7
	16.0	16.4	20.5
	15.8	18.1	20.3
	15.6	16.2	20.9
	16.0	15.8	19.9
Average.....	16.2	17.9	20.7

Each brick was marked and weighed before and after the test. The number of bricks in each test of the soft variety was ten, and of the hard variety was nine. Thus there were fifty specimens of soft brick and forty-five specimens of the hard brick tested with each of the three kinds of shot. The individual losses of the soft bricks tested with each kind of shot were collected together and arranged in order from the smallest to the largest. The same was done for the hard bricks. The result is shown graphically in the accompanying diagrams. Fig. 15 shows the result for the hard brick and Fig. 16 for the softer brick. Each circle represents the loss of one brick. No conclusion as to relative uniformity of hard and soft bricks in general can be drawn from a comparison of these two tables; as each one gives the results for one make of brick only. But the relative effects of the different kinds of shot are brought out clearly. It will be noticed that each make of brick contains bricks of different degrees of hardness, but that the majority keep fairly near the average. In drawing conclusions as to the effect which the character of the shot has upon the results of the tests, the extremely hard or soft bricks, which are evidently quite different from the usual run, can be disregarded. It is evident in the present instance that there are a few soft brick which exercise an undue influence upon the average results as at first tabulated. The most important conclusions to be drawn from these tests are that the shape of the shot has small influence on the result, and that the difference in the results obtained with chilled steel and with cast iron shot is about 4 per cent., and is not dependent on the hardness of the brick.

Results of 15 Rattler Tests of *SOFT BRICK*  
 Showing the per cent of wear of each brick.

Tests made with  $\left\{ \begin{array}{l} \text{OLD CAST IRON SHOT } \circ\circ\circ\circ \\ \text{NEW CAST IRON SHOT } \circ\circ\circ\circ \\ \text{CHILLED STEEL SHOT } \bullet\bullet\bullet\bullet \end{array} \right.$

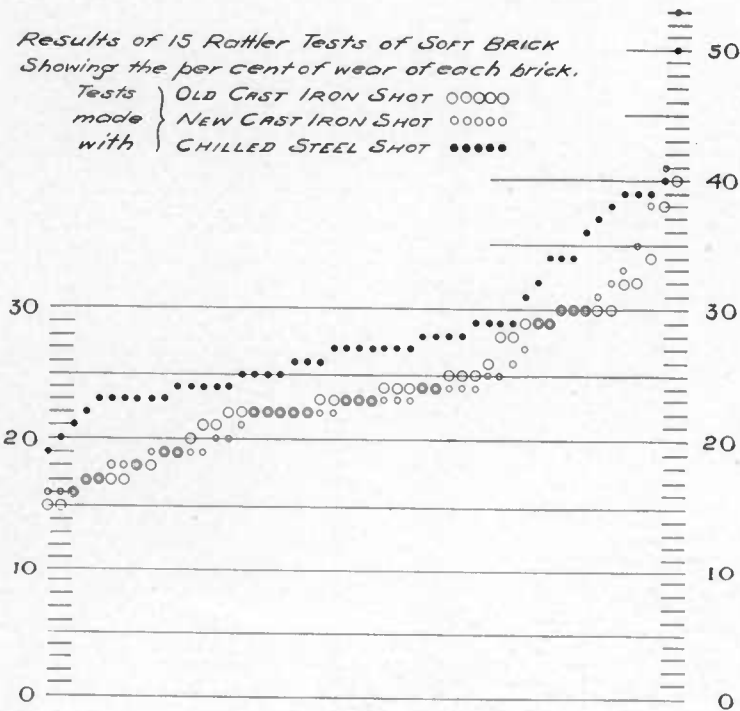

FIG. 15.

Results of 15 Rattler Tests of *HARD BRICK*  
 Showing the per cent of wear of each brick

Tests made with  $\left\{ \begin{array}{l} \text{OLD CAST IRON SHOT } \circ\circ\circ\circ \\ \text{NEW CAST IRON SHOT } \circ\circ\circ\circ \\ \text{CHILLED STEEL SHOT } \bullet\bullet\bullet\bullet \end{array} \right.$

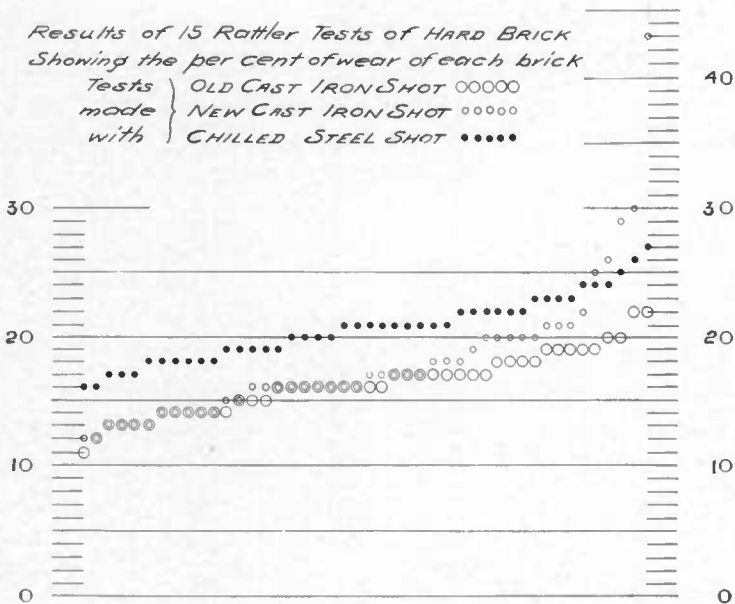

FIG. 16.

## CEMENT TESTS.

## TESTS OF CONCRETE BARS.

These tests were made at the request of the City Engineer of Baltimore, who desired some data showing the comparative strength of concretes made with different cements and in different ways. The concrete bars were made by the City Engineer's Department, and were kept in the moulds for 24 hours, in water 6 days and were then exposed to the air until tested. The tests were made by breaking the bars midway between two supports. The first lot of bars tested were about 5 feet long, by 4 inches wide, by 4 inches deep. These bars were broken at three places; first at the centre and then each half was in turn broken at its centre. The position of the breaks is indicated as "end" or "centre" breaks in the adjoining table. The modulus of rupture was computed from the ordinary beam formula. The bars in the second series of tests were about 30 inches long, by 6 inches wide, by 6 inches deep. The first lot was made of concrete mixed with 1 part cement, 3 parts sand, and 6 parts broken stone, while the second lot was composed of concrete made 1 part cement, 3 parts sand, and 7 parts broken stone. The results have been tabulated as follows:

RESULTS OF TESTS OF 4-INCH  $\times$  4-INCH CONCRETE BARS.  
CONCRETE MIXED 1 PART CEMENT, 3 PARTS SAND, AND 6 PARTS STONE.

Specimen marked.	Date.		Age in days.	Position of breaks.	Total load in lbs.	Distance between supports.	Modulus of rupture in lbs. per sq. in.
	Made 1902.	Tested 1902.					
Atlas No. 1.....	Apr. 28	June 5	32	center	385	30"	406
" ".....	"	"	32	end	396	30"	397
" ".....	"	Dec. 9	225	end	396	28"	369
Atlas No. 2.....	Apr. 30	"	223	center	550	30"	387
" ".....	"	"	223	end	678	30"	490
" ".....	"	"	223	end	576	30"	416
Atlas No. 3.....	"	"	223	center	?	..	?
" ".....	"	"	223	end	774	30"	542
" ".....	"	"	223	end	779	30"	572
Paragon No. 1.....	"	"	223	center	440	30"	403
" ".....	"	"	223	end	330	30"	303
" ".....	"	"	223	end	484	24"	336
Paragon No. 2.....	"	Dec. 10	224	center	462	30"	386
" ".....	"	"	224	end	481	30"	370
" ".....	"	"	224	end	440	30"	383
Paragon No. 3.....	May 16	Dec. 9	207	center	...	..	...
" ".....	"	"	207	end	550	30"	505
" ".....	"	"	207	end	779	24"	500



RESULTS OF TESTS OF 6-INCH × 6-INCH CONCRETE BARS.  
CONCRETE MIXED 1 PART CEMENT, 3 PARTS SAND, AND 7 PARTS STONE.

Specimen marked.	Date.		Age in days.	Total load in lbs.	Distance between supports.	Modulus of rupture in lbs. per sq. in.
	Made 1902.	Tested 1902.				
Atlas No. 1.....	Oct. 15	Dec. 10	56	3300	24"	532
Atlas No. 2.....	" 17	" 10	54	2376	24"	371
Atlas No. 3.....	" 23	" 10	48	880	24"	(flaw.)
Paragon No. 4.....	" 27	" 12	46	1342	24"	272
Paragon No. 5.....	" 29	" 12	44	1588	24"	243
Paragon No. 6.....	Nov. 1	" 12	39	1650	24"	267

## TENSILE STRENGTH OF CEMENT.

A new method and a new apparatus were devised by the writer to eliminate all variations in the results of tensile tests on cements due to the unknown variable stresses sustained by the test specimen in the present method of making tensile strength tests of cement. The apparatus consists, as a glance at Plate XII, Figs. 1 and 2 will show, of three parts; a cylinder, A, with a movable piston and filled with water or some other liquid; a cylinder, B, with elastic sides which is connected with the cylinder carrying the piston, and a pressure gauge connected with the other two cylinders. The piston which moves in the cylinder, A, is attached to a threaded rod working through a nut at the top of the cylinder thus the motion of the piston can be regulated to a nicety. When the piston descends the pressure thus developed within the apparatus is registered by the gauge. The pressure forces the water into the middle cylinder tending to swell the elastic portion of it, at B, which consists of an india rubber tube.

For testing cement, circular cylindrical rings are made. One of the rings, which can be seen in position in Plate XII, Fig. 1, is put over the centre cylinder, after which a bell-shaped cap, D, is placed upon the test ring and is held in place by a nut, E, which is screwed lightly against the cap. If this nut were not used the rubber tube in expanding would tend to raise the cap and the rubber would be forced between the cap and the cement ring which would result in bursting the rubber tube. The piston is then screwed

down by means of a handle, F. This causes the rubber tube to swell pressing it against the inner side of the cement ring. A uniform pressure is thus secured over the entire inner surface of the ring and, up to the moment of rupture, every section of the ring is under exactly the same tensile stress, assuming that the walls of the ring are everywhere of equal thickness. It is also evident that all rings of the same size are subjected to exactly the same conditions so far as the application of the pressure is concerned, and the difference in the pressures at which different rings are ruptured must be occasioned by a corresponding difference in the strength of the rings. In other words the apparatus treats all specimens exactly alike, not subjecting one to different stresses from another, as is the case with the usual method of making tensile tests of cement. It is also practically impossible for any shock to be given to the specimen while under stress because the air which is inclosed within the apparatus, acting as a cushion, prevents any sudden changes of pressure.

Inasmuch as it is known from the theory of hydraulic pressure that the heights of the test rings under the above conditions have no bearing on the pressure registered by the gauge, it is therefore not necessary that all the rings tested be of the same height. The chief care to be taken in this particular is to have each ring of the same height throughout. It is also known that the average strain per square inch which a section of the ring sustains has the same ratio to the pressure registered by the gauge that the inside radius of the ring has to its thickness. While the average tensile strength thus obtained for a section of a ring under internal pressure is not the maximum tensile strength developed in the ring, at the same time true comparative values of the strength of the materials of different rings of like dimensions can be deduced. However, the greater the ratio between the inside radius and the thickness of the cement rings the more nearly will it be possible to show the maximum tensile strength of the cement. If it were practical to make extremely thin rings an exceedingly close approximation to the maximum tensile strength of the rings could be determined, but the same results can be obtained in a somewhat different way. After having

made a comparatively thick ring, one thick enough to give the requisite strength to withstand ordinary handling, saw cuts are made in opposite sides of the ring parallel to its axis. The ring should be sawed through from the outside until the section remaining uncut is relatively small compared to the inside radius of the ring. In this way it is possible to test an extremely thin ring and it may be that the results of future experiments will show that this is the best method to follow.

It is possible, knowing the relation that exists between the pressure per square inch, as registered by the gauge, the tensile strength per square inch developed by the ring, and the dimensions of the ring, to so proportion the rings that the tensile strength developed will be some convenient multiple of the gauge reading. For example, with a ring having an inside radius of one inch and walls one-half inch thick, the average pressure per square inch sustained by a single section of this ring would be twice the pressure shown by the gauge.

So far experiments have been carried on with rings made in two ways, cutting them with a diamond drill from a solid slab of cement mortar which has set the proper time, and by moulding in moulds. Both methods were successful with neat cement, but mortars composed of sand and cement could not be as successfully drilled with the style of drills at hand. Another feature noticed in connection with drilling cement rings was the lack of uniformity in the size of the rings so that it was necessary to measure each section in order to determine the results. No such difficulty however, has been experienced in moulding rings. In order to have them fit in the testing machine it will occasionally be necessary to grind the end of a ring so that it will present a flat surface. It is very easy to do this and the amount of grinding required seldom takes over one or two minutes. This precaution is necessary to prevent the rubber tube from blowing out between the test specimen and the brass caps which inclose it.

A form of mould that has been successfully used for making the cement rings is shown in Fig. 17. The moulds are made of brass and may be either single or in gangs for as many as five briquettes.

Moulds for a larger number are unwieldy and are difficult to make with satisfactory joints. The moulds consist of a base, C, on which a top piece, A, in two sections, forming the outside of the cement rings, is fastened at each corner by means of small bolts, one of which is shown in the diagram by dotted lines. Holes are bored in the base, in which are placed the centre cores, B, which rest by a shoulder on the top of the base. These cores are provided with two small

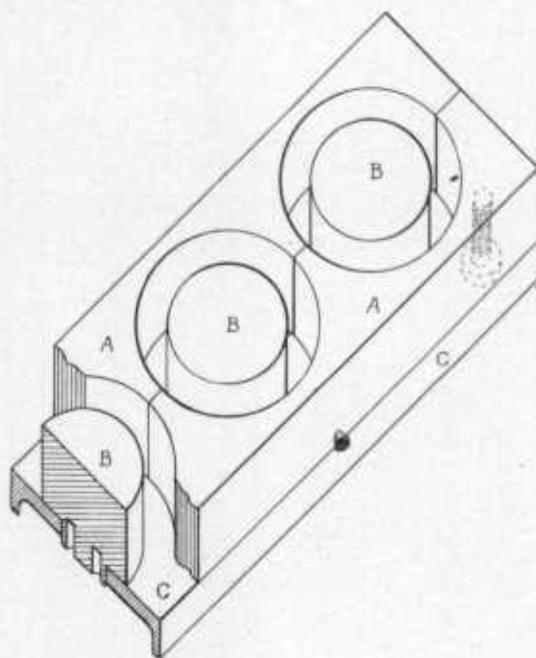

FIG. 17.—Sketch showing plan, half section and half elevation of mould for making cement rings used to determine the tensile strength of cements.

holes on the under side in which a spanner wrench may be inserted so as to turn the cores when removing them. The cores are tapered about four thousandths of an inch. If comparatively dry mixtures are used the cores may be removed immediately after the cement ring is made. If the mixtures are too moist to allow this the cores may be turned around a number of times, so as to prevent the cement from clinging and then left until the cement has set. To remove

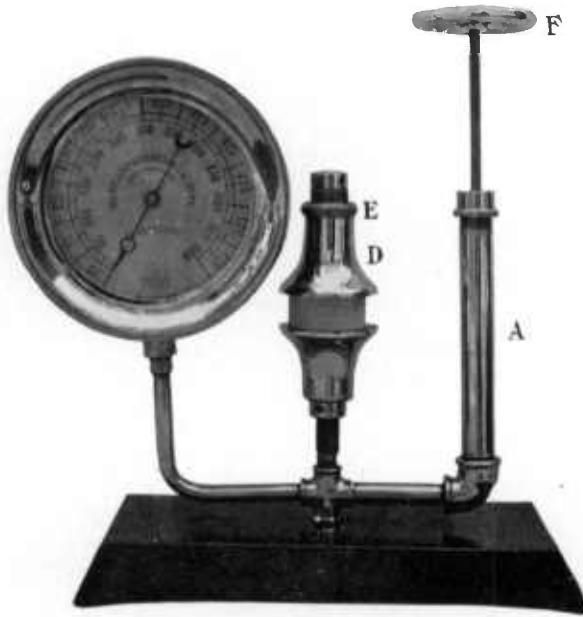
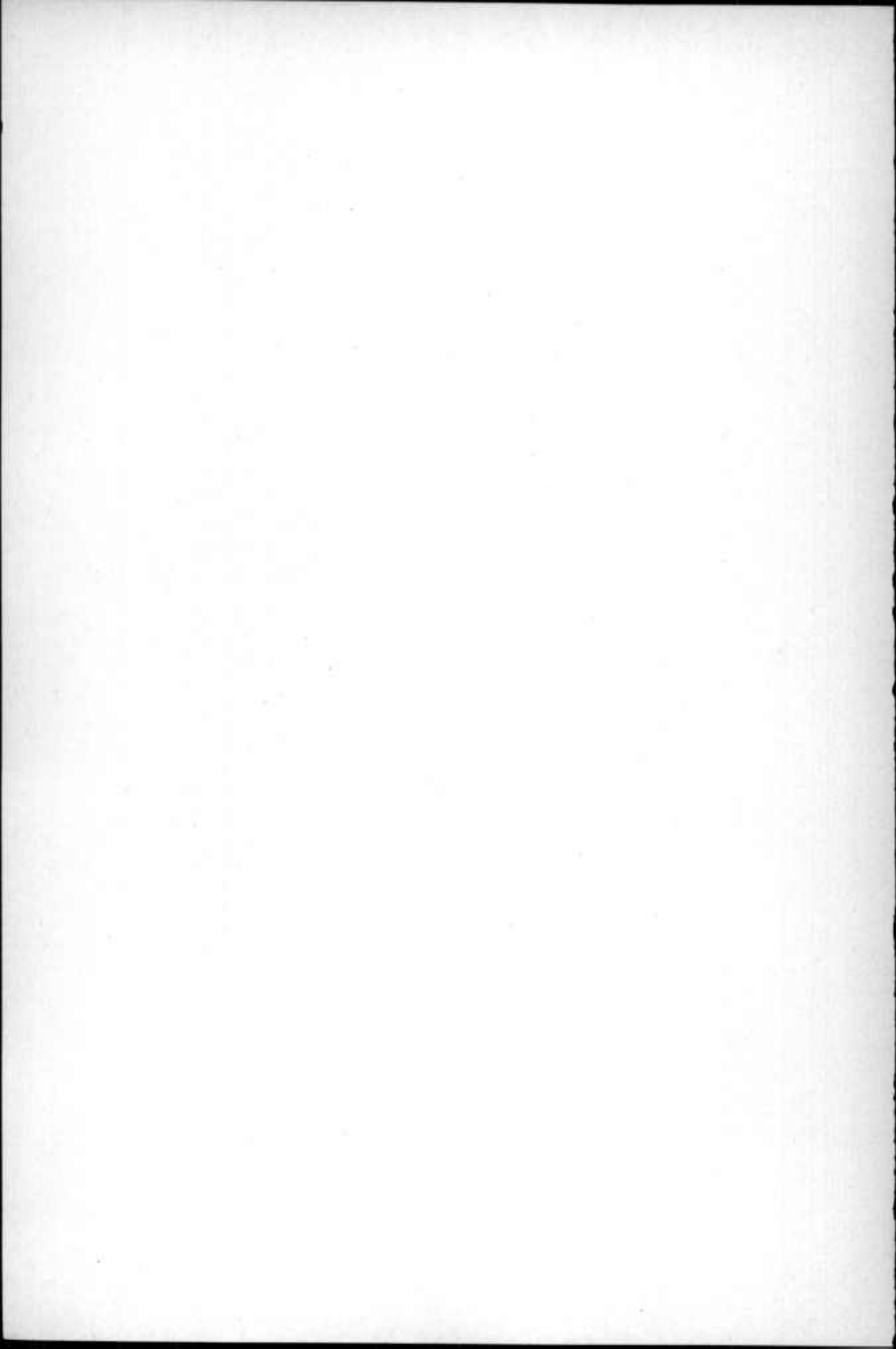

FIG. 1.—MACHINE WITH CEMENT RING IN POSITION READY FOR A TEST.



FIG. 2.—MACHINE AFTER A TEST WITH THE TOP CAP REMOVED, SHOWING THE BROKEN CEMENT RING AND DISTENDED RUBBER CYLINDER OR TUBE.

HYDRAULIC CEMENT TESTING MACHINE.



the rings from the mould, the cores having been taken out, the base plate is unfastened and then the sides, A, are gently pried apart. If the moulds are well greased with alban grease very little trouble will be found on account of the rings adhering.

The cement testing machine described above has been in use in this laboratory for the last five months during which time a large number of tests have been made. Many of these, however, were of a preliminary character; and systematic tests have not yet been made in sufficient number to determine the relation between results obtained by this method and that ordinarily used. So far as the work has progressed it appears that the new method will give more nearly the true comparative tensile strength of different cements. Direct pressures of over 800 pounds per square inch are very readily developed, which with rings having walls one half as thick as their inside radius means an average stress of 1600 pounds per square inch on each section of the test ring. The chief difficulty that is to be overcome is the removal of the cement rings from the moulds without injury; but with the pattern of mould shown in Fig. 17 satisfactory rings can be made.

Cement testing with this machine will shortly be undertaken at the laboratory of the Massachusetts Institute of Technology, Boston, and at the Road Material Laboratory, Department of Agriculture, Washington, D. C.

#### WEARING TEST OF STONE AND BRICK.

The object of this test is to determine the relative wearing qualities of different rocks, paving bricks, and other materials having a similar granular structure so that an accurate comparison of their resistance to wear can be made. The test duplicates as nearly as possible the wearing action to which steps, stone floors and walks are subjected by the action of foot travel, which produces a grinding or wearing away of the particles without inflicting any impact or blow such as is sustained by materials when used for street paving. The test of the latter very properly introduces impact, as well as wear, as they are combined in the different rattler tests; but where there is no impact to be resisted the test should not have this feature.

The Dorrey test, as it is known, is the French method for determining the wearing qualities of rock. This test employs rectangular shaped pieces which are held in a sliding clamp so that the rock may be constantly pressed against the face of a revolving iron disk. The wearing action is obtained by feeding quartz sand and water to the disk as it revolves. The height of the specimen is measured before and after the test and the difference is taken as the measure of wear. In this test it is necessary to have an automatic arrangement for feeding a given amount of sand and water per minute and to have the same number of revolutions of the disk per minute in each test. The apparatus used for this test is somewhat complicated and expensive to make.

After a careful study of the Dorrey test it seemed that it could be simplified and at the same time made more accurate. The test as devised in this laboratory does away with much of the mechanism of the Dorrey test and, it is believed, makes it much easier to obtain similar results in different laboratories with the same material. The test-pieces used are cylindrical cores one inch in diameter, made with a diamond drill from specimens of the material to be tested. They can be made with far less work than is necessary to prepare the rectangular-shaped test-pieces. The apparatus for making the test is shown in Fig. 18, to which the letters in the following description refer: The cores, R, are placed in a brass sleeve, B, in which they are clamped by a key, D, and thus held firmly in position. The brass sleeve, B, in which the rock core is elamped, slides within a second brass sleeve, A, in which is cut a longitudinal slot, E, for a guiding-pin to pass through which prevents the rock core from rotating. There are two sets of sleeves or guides which are mounted securely in the cross-piece, F, and at equal distances and on opposite sides from the center of the grinding wheel, W, which may be a carborundum or an iron disk to which water and sand are fed through a tube at the center.

The test is made as follows: Cores of two varieties of rock are prepared and clamped in the guides on each side and firmly pressed against the face of the wearing wheel by a five-kilogramme weight, C, which is suspended on a pivot, H, at the end of a tube, G, resting



directly on the rock core, R. The weight is hung in this manner so as to insure always a direct downward pressure which will be evenly distributed over the surface of the test core. After a certain number of revolutions the amount each core has worn away is measured by comparing their lengths before and after the test. The ratio of the differences so found is the ratio of the wear sustained by the two samples in question. Thus if one wears  $\frac{1}{4}$  of an inch while the other wears  $\frac{1}{2}$  of an inch, the second material will wear twice as fast, under the same conditions, as the first.

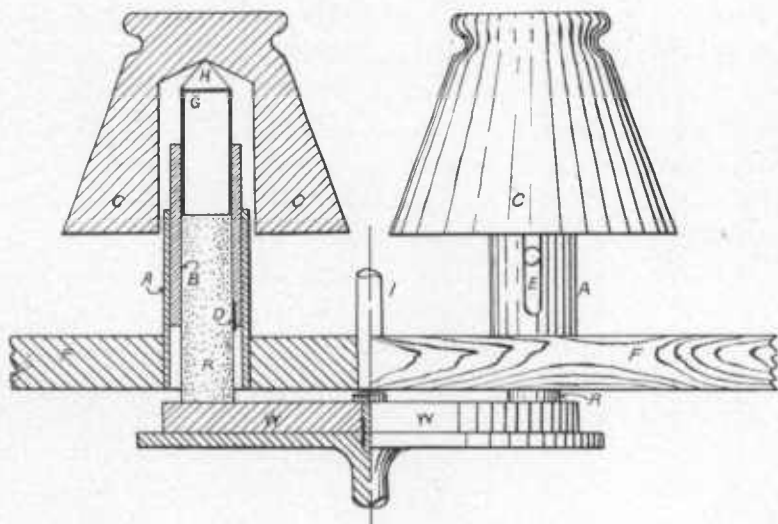

FIG. 18.—Sketch showing a half section and half elevation of machine for making wearing tests of stone and brick.

It is evident that the test-pieces are subjected to exactly the same conditions whatever the nature of the grinding disk. If some homogeneous limestone or sandstone is taken as a standard and a core of this material placed in one side of the apparatus and a core of some other material in the other, and, after a given time, the wear of each core is observed, the relative wear of the two materials can thus be obtained. Each time a new material is to be tested a test-piece of the standard material is also tested and the rate of wear of the new

material is expressed in terms of the rate of wear of the standard. It is not, however, necessary to test a new sample with the standard material in order to ascertain its relative wearing quality, as this will be known if the new material is tested with a core whose rating has already been determined.

In making the tests in the above manner only comparative results are used, and all variations due to the method of conducting the test are practically eliminated. The time of running a test depends on the rapidity with which the test-pieces wear. If the material to be tested is exceedingly hard the test is conducted until an appreciable amount has been worn away from the harder material. The size of the grinding disk is not essential so long as the test-pieces are mounted at equal distances from the center and a low speed maintained. It is better, however, to use a wheel large enough, so that the inside and outside edges of the cores will receive approximately the same wear. A twelve-inch carborundum wheel has been used in making some of the tests in this laboratory and found to be in every way satisfactory, except that it was frequently necessary to roughen the face of the wheel which became partially polished. This effect is not observed if a carborundum wheel is run at a high rate of speed, but the difference in the hardness of many materials is not distinguished by such speeds.

While a number of preliminary tests have been made there has not been sufficient time, however, to make a systematic series of tests, for which reason no results are at present ready which would be of general value.

(FORM OF SPECIFICATIONS USED BY MARYLAND GEOLOGICAL SURVEY.)

STATE OF MARYLAND.

.....of.....

CONTRACT AND SPECIFICATIONS.

For .....  
 as provided for in the specifications annexed hereto and plans and profiles made by .....  
 .....  
 and dated.....190., made and concluded this.....  
 day of.....190., between the.....  
 of.....party of the first part, and.....  
 party of the second part.

Witnesseth: That in consideration of the sums hereinafter mentioned to be paid by the party of the first part, and penalty expressed in the bond of even date with these presents and annexed hereto, the said party of the second part agrees with said party of the first part, at his own proper cost and expense, to do all the work and furnish all materials necessary to do the work hereinafter described in the specifications herein contained and in full compliance with the terms of this agreement.

In witness whereof the parties hereto have set their hands the date herein named.

.....of.....  
 Party of the first part.

.....  
 Party of the second part.

WORK TO BE DONE.

ESTIMATED QUANTITIES.

The following quantities of the work to be done are approximate only and are intended principally to serve as a guide in figuring out the bids. The quantities may be subsequently increased or diminished as may be deemed necessary by the.....of.....  
 as hereinafter provided in the specifications.

EXCAVATION

Earth	cu. yds.
Borrow	cu. yds.
Ledge	cu yds.

MASONRY

Dry Rubble	cu. yds.
Cement Rubble	cu. yds.
.....	cu. yds.
.....	cu. yds.

VITRIFIED CLAY PIPE

.....inch	ft.
.....inch	ft.
.....inch	ft.

IRON WATER PIPE	
.....inch	ft.
.....inch	ft.
.....inch	ft.
MACADAM CONSTRUCTION	
Class A	sq. yds.
Class B	sq. yds.
Class C	sq. yds.
TELFORD CONSTRUCTION	sq. yds.
RESURFACING	sq. yds.

MATERIALS AND TOOLS.

The Contractor is to furnish all materials, tools, machinery and other means of construction, all labor, and to do all the work in connection with the proposed improvement of said road, including all grading, draining, and surfacing in accordance with these specifications, and plans accompanying, and requirements under them of the Engineer.

PRICES.

In consideration of the following prices, to be paid as herein provided by the party of the first part to this contract, the Contractor, party of the second part to this contract, agrees to furnish all materials, tools, machinery, and other means of construction, all labor and to do all work as provided in the specifications, to wit:

For EARTH EXCAVATION of all descriptions (except ledge), including grubbing, clearing and incidental work,	.....cents (\$....) per cu. yd.
For BORROW EXCAVATION, including all grubbing, clearing and incidental work,	.....cents (\$....) per cu. yd.
For LEDGE EXCAVATION, including all incidental work,	.....cents (\$....) per cu. yd.
For DRY RUBBLE MASONRY, including all materials and incidental work, except excavation,	.....cents (\$....) per cu. yd.
For CEMENT RUBBLE MASONRY, including all materials and incidental work, except excavation,	.....cents (\$....) per cu. yd.
For VITRIFIED CLAY PIPE, including all materials, excavation (except ledge) and incidental work,	
.....inch,	.....cents (\$....) per ft.
.....inch,	.....cents (\$....) per ft.
.....inch,	.....cents (\$....) per ft.

For IRON WATER PIPE, including all materials, excavation (except ledge) and incidental work:

....inch, not less than....inch thick,	.....cents (\$..) per ft.
....inch, not less than....inch thick,	.....cents (\$..) per ft.
....inch, not less than....inch thick,	.....cents (\$..) per ft.

For MACADAM CONSTRUCTION complete in place on the road, including preparation of road-bed, making shoulders, all materials, rolling and incidental work as provided for in the specifications:

Class A,	.....cents (\$....) per sq. yd.
Class B,	.....cents (\$....) per sq. yd.
Class C,	.....cents (\$....) per sq. yd.

For TELFORD CONSTRUCTION complete in place on the road, including preparation of road-bed, making shoulders, all materials, rolling and incidental work as provided for in the specifications:

.....cents (\$....) per sq. yd.

For RESURFACING complete in place on the road, including preparation of road-bed, making shoulders, all materials, rolling and incidental work as provided for in the specifications:

.....cents (\$....) per sq. yd.

For EXTRA WORK:

## PRELIMINARY CONSTRUCTION.

### EARTH WORK.

#### GRADING.

Wherever a change in the grade of the road is shown on the profiles, or is indicated by the Engineer, material is to be excavated or filled in, as the case may be, until the proper grade is reached in conformity with the accompanying plans, profiles and cross-sections.

The road is to be graded to the width and shape as shown on the plans or as indicated by the Engineer.

#### EXCAVATION.

All materials excavated and used for filling are to be paid for as excavation only.

Materials used for filling and brought from outside the lines of the work are to be paid for as borrow excavation.

Only boulders measuring over 1/2 cubic yard or ledge requiring blasting for its removal will be paid for as ledge excavation. No allowance will be made for ledge excavation more than 6 inches below sub-grade.

All other materials excavated within the lines of the work are to be paid for as earth excavation.

All measurements for earth-work or ledge are to be made in excavation.

## EMBANKMENTS.

The material for embankments is to be spread in layers not exceeding 12 inches in thickness until the proper grade is reached. No roots, stumps or other materials, in the opinion of the Engineer, unfit for the work are to be used.

## SURPLUS MATERIAL.

All surplus material excavated is to be used in widening the embankments.

In case of a deficiency of material for the embankments, additional material will be had either from such points within the lines of the work or from such nearby points outside as the Engineer may indicate.

## SLOPES.

Slopes in cuts shall be left at an inclination of 1 horizontal to 1 vertical unless otherwise directed by the Engineer.

The slopes of embankments are to be nowhere steeper than  $1\frac{1}{2}$  horizontal to 1 vertical.

All slopes are to be left in a neat and presentable condition free from all rubbish and brought to a proper shape.

## DRY RUBBLE MASONRY.

## MATERIAL.

Dry rubble masonry shall be composed of sound quarry stone free from structural defects, presenting good beds for material of this kind, and of suitable sizes and shapes for the work. No pieces of stone with rounded surfaces are to be used.

The stones are to be laid so as to give a bond of at least 6 inches.

One-third of the work is to consist of headers.

The larger stones are to be used for foundation purposes.

## COVERING STONES.

Covering stones, used over culverts, shall not be less than 12 inches thick nor less than  $\frac{1}{4}$  their length in thickness. They shall be sound granite or gneiss or other rock approved by the Engineer. Covering stones shall have a bearing on the side walls of at least 12 inches. They are to be laid as closely together as possible and crevices filled with spalls and cement mortar.

## CEMENT RUBBLE MASONRY.

## MATERIAL.

Cement rubble masonry shall be composed of sound quarry stone free from structural defects, presenting good beds for material of this kind, and of suitable sizes and shapes for the work. No pieces of stone with rounded surfaces are to be used.

The stones are to be laid in courses not less than 12 inches thick with alternate headers and stretchers.

The joints are not to be over 1 inch wide and are to be well filled with cement mortar.

## CEMENT MORTAR.

Cement mortar is to consist of 1 part American cement and 2 parts clean, sharp sand or 1 part Portland cement and 3 parts clean, sharp sand. The cement is to be kept until used in tight barrels or bags thoroughly protected from all moisture.

No cement is to be used that is not approved by the Engineer.

No mortar is to be used that has stood over 30 minutes, or has taken an initial set, or has been retempered.

## DRAIN-PIPE.

## MATERIAL.

All pipe, either clay or iron, must be sound and free from cracks and distortions.

No iron pipe of less thickness than as agreed upon under prices to be paid is to be used.

Unless otherwise directed by the Engineer the joints of the pipe are to be calked with cement mortar.

## LAYING.

Trenches for drain-pipe are to be excavated to the grade as given by the Engineer. All pipe must be laid to a true alignment. Each section of pipe must have a firm bearing throughout its length. If, after laying, any pipe shows signs of settlement, or is not in true alignment, it is to be replaced by the Contractor at his own expense, upon notice from the Engineer to that effect.

## ENDS.

The exposed ends of pipe-drains are to be protected by such masonry as the Engineer may direct.

## PRICE.

No other allowance than the price per foot for laying pipe, as herein agreed upon, will be made for excavating the trench except where the Contractor is directed to dig a trench more than 3 feet deep, allowance then being made for all material excavated beyond 3 feet in depth and for a width not exceeding 1 foot on each side of the pipe.

## MACADAM CONSTRUCTION.

Macadam construction is to be used wherever directed by the Engineer or provided for in the plans. The width and thickness required at different points is to be that designated by the Engineer.

## CLASS A, B AND C.

There are to be three classes of macadam construction to be known as A, B and C, respectively. Each class shall consist of three courses of

broken stone. The thickness after rolling, of the various courses in each class, is to be as follows:

	1st Course.	2d Course.	3d Course.
Class A	4 inches	2 inches	To be as hereinafter described.
Class B	5 "	3 "	
Class C	6 "	4 "	

Each course of broken stone is to be applied as herein specified.

#### ROAD-BED.

##### MATERIAL.

The road-bed for macadam construction is to consist of the natural earth road-bed prepared and rolled until firm and hard in the following manner:

If sandy or other soil be encountered which will not compact readily under the roller, a small amount of clay, or other means satisfactory to the Engineer, shall be used until a firm, hard surface is obtained after rolling.

##### CUTS AND FILLS.

In cuts and fills, unless otherwise specially directed, the road-bed is to be graded to a width of.....feet, and is to be free from all spongy and vegetable matter, roots and stumps. The portion of the road-bed prepared for the broken stone surface is to be.....feet wide and brought to the grades and cross-sections as shown on the plans and rolled with a steam-roller until firm and hard. All depressions that may appear during the rolling are to be filled with earth and re-rolled until an even surface with a proper grade and cross-section is obtained.

##### OLD EARTH ROAD-BED.

Where no change, from the present grade of those portions of the road not already surfaced with stone, is shown on the profile, the road-bed is to be shaped to the proper cross-section and slight elevations with contiguous depressions removed so as to form an even and smooth surface. The road-bed is to be rolled to a firm, smooth surface before the application of the broken stone.

##### TRENCH FOR THE BROKEN STONE.

The portion of the road-bed prepared for the broken stone is to be below the sides by an amount equal to the thickness of the first course of stone so as to prevent the broken stone spreading at the sides.

##### SHAPE.

The shape for the road-bed is to be as shown on the accompanying plans and is to have a cross-slope of.....inches to 1 foot.



## EXCAVATION.

No allowance will be made the Contractor for any excavation in preparing the road-bed, for either telford or macadam construction, which does not require an average change in the present grade of the road-bed of over 8 inches. The price for all work done in preparing the road-bed, as above described, is to be included in the price stipulated for macadam, telford or other construction of whatever description.

## FIRST COURSE.

## MATERIAL.

The first course of the macadam construction is to consist of sound stone broken to sizes varying from 3 inches to 2 inches, no piece to have a diameter greater than 3 inches. This is to be known as "No. 1" size.

No material is to be used which, in the opinion of the Engineer, is unfit for the work. If any such material is put upon the road it shall be removed immediately upon notice from the Engineer and replaced by proper material at the Contractor's expense.

## SPREADING.

No broken stone is to be spread before the road-bed has been made as specified.

The broken stone is to be spread upon the road-bed, prepared as herein described, with shovels from piles alongside the road or from a dumping board, or it may be spread directly from wagons especially constructed for this purpose and approved by the Engineer; but in no case shall the broken stone be dumped directly upon the road-bed.

## ROLLING.

After the broken stone for the first course has been spread to an uniform thickness, and has a proper cross-section, it is to be rolled with a steam-roller, weighing not less than 10 tons, until it is compacted to form a firm, smooth surface. Should any difficulty be experienced while rolling in having the stone readily compact, sprinkling with water or lightly spreading with sand or other material, as the Engineer may direct, shall be employed. The rolling must begin at the sides and work toward the center thoroughly covering this space with the rear wheel of the roller.

## UNEVENNESS OR DEPRESSIONS.

Should any unevenness or depressions appear, during or after the rolling of the first course, they are to be remedied immediately with broken stone and re-rolled until a firm, even surface is obtained.

## THICKNESS.

The thickness of the first course of broken stone, after thorough rolling, is to be that of the class of macadam construction specified for any particular place as described under class A, B and C.

If, for any reason, a greater thickness than specified is made by the Contractor no extra allowance for such additional thickness will be made.

### SHOULDERS.

After the first course has been made as herein described, earth-shoulders are to be constructed along each side of the road for a width of at least.....feet as shown on the accompanying plans.

Against these shoulders is to be spread the broken stone for the second course as herein described. The shoulders are to contain a sufficient quantity of earth so that a smooth and continuous slope will be obtained after the shoulders and second course are rolled. The shoulders with the.....feet of stone will make a total width of.....feet to be shaped with a cross-slope of.....inch to 1 foot.

Material for the shoulders must be free from roots, stumps or other vegetable matter and thoroughly compacted by the roller. Material with a proportion of sand, such as prevents it when dry from compacting readily under the roller, is not to be used.

No material which is considered unfit for the work by the Engineer is to be used, and where any such is put on the work it shall be immediately removed, upon notice by the Engineer, at the Contractor's expense.

### SECOND COURSE.

The second course of the macadam construction is to be the same width as the first course.

### MATERIAL.

The second course is to consist of stone broken to sizes varying from 1 inch to 2 inches; no piece to have a greater diameter than 2 inches. This will be known as "No. 2" size.

Unless otherwise specified the rock shall be trap rock with a "coefficient of wear," as determined by tests made at the laboratory of the Highway Division of the Maryland Geological Survey, of not less than 15.

### SPREADING.

The broken stone for the second course is not to be spread before the first course has been completed and shoulders made as herein specified.

The broken stone is to be spread upon the first course, prepared as herein described, with shovels from piles alongside the road or from a dumping board, or it may be spread directly from wagons especially constructed for this purpose and approved by the Engineer; but in no case shall the broken stone be dumped directly upon the first course.

### ROLLING.

After the broken stone for the second course has been spread to an uniform thickness, and has a proper cross-section, it is to be rolled with a steam-roller, weighing not less than 10 tons, until it is compacted to form a firm, smooth surface. Should any difficulty be experienced while rolling in having the stone readily compact, sprinkling with water or lightly spreading with sand or other material, as the Engineer may direct, shall be employed.

The rolling is to begin at the sides, the shoulders first being rolled firm so as to prevent spreading of the broken stone in the second course. When completed the surface of the shoulders and of the second course of broken stone should be smooth and continuous with a cross slope of..... inches to 1 foot.

#### UNEVENNESS OR DEPRESSIONS.

If any unevenness or depressions appear during or after the rolling of the second course, either on the surface of the shoulder or the broken stone, suitable material shall be added to remove all such unevenness or depressions, earth being used on the shoulders and No. 2 stone for the broken-stone surface.

#### THICKNESS.

The thickness of the second course of broken stone, after thorough rolling, is to be that of the class of macadam construction, specified for any particular place, as described under class A, B and C.

If, for any reason, a greater thickness than specified is made by the Contractor, no extra allowance for such additional thickness will be made.

#### THIRD COURSE.

##### MATERIAL.

The third course of macadam construction is to consist of trap rock screenings varying in size from dust to 1-inch pieces. Other material than trap rock screenings may be used if approved by the Engineer.

##### SPREADING.

After the second course of No. 2 stone has been rolled and completed as above described, the screenings are to be spread, but in no case are screenings to be used until the second course has been thoroughly rolled and compacted. The screenings are to be spread dry with shovels from piles alongside the road, or from dumping boards, but in no case are the screenings to be dumped directly on the second course. The quantity of screenings used is to be such as will just cover the second course.

##### WATERING AND ROLLING.

After the screenings are spread they are to be sprinkled with water from a properly constructed sprinkling cart, and then rolled with a steam-roller weighing not less than ten tons. The amount of water necessary is to be determined by the Engineer. The rolling is to begin at the sides and to continue until the surface is hard and smooth and shows no perceptible tracks from vehicles passing over it.

If, after rolling the screenings, the No. 2 stone appears at the surface, additional screenings shall be used in such places.

The rolling and watering shall continue until the water flushes to the surface. The rolling is to extend over the whole width of the road including the shoulders.

UNEVENNESS AND DEPRESSIONS.

If any unevenness or depressions appear in the road surface after rolling the screenings, No. 2 broken stone and screenings shall be used until they are removed and the finished surface conforms to the proper cross-section, as shown on the accompanying plans, and presents a smooth, even appearance.

PRICE PAID FOR MACADAM CONSTRUCTION.

The price herein agreed upon to be paid for macadam construction is to include all work and materials necessary to do the work as herein specified under macadam construction.

TELFORD CONSTRUCTION.

Telford construction is to be used wherever directed by the Engineer or provided for in the plans. The width required at different points is to be that designated by the Engineer.

ROAD-BED.

The road-bed for the telford construction is to be made in the manner specified for the road-bed of the macadam construction.

FIRST COURSE.

MATERIAL.

The first course of the telford construction is to consist of sound stone with sharp corners broken to the following dimensions: Depth from 5 to 8 inches; width from 3 to 6 inches; and length not exceeding 16 inches.

LAYING.

Broken stone for the first course of the telford construction is not to be laid before the road-bed has been made as specified. The pieces of stone are to be set by hand on edge and laid close together lengthwise across the road, resting on the broadest edge. Protruding corners are to be broken off and the interstices filled with small pieces.

ROLLING.

After the stone for the first course has been laid and brought to a proper cross-section, the spaces filled with spalls and made as compact a layer as possible, it is to be rolled with a steam-roller weighing not less than ten tons. The interstices must not be filled with earth.

UNEVENNESS OR DEPRESSIONS.

Should any unevenness or depressions appear during or after the rolling of the first course, they are to be remedied immediately by broken stone and rolled until firm.

THICKNESS.

The thickness of the first course for telford construction is to be 8 inches when finished.

SHOULDERS.

After the first course has been made as herein described, earth shoulders are to be constructed along each side of the road for a width of at least.....feet as shown on the accompanying plans. Shoulders are to be made as already specified for shoulders of the macadam construction.

SECOND COURSE.

The second course of the telford construction is to be the same width as the first course and made in the same manner and of similar materials as specified for the second course of the macadam construction.

THICKNESS.

The thickness of the second course after thorough rolling is to be 4 inches.

If for any reason a greater thickness than specified is made by the Contractor, no extra allowance for such thickness will be made.

THIRD COURSE.

The third course of the telford construction is to be made in the same manner and of similar materials as specified for the third course of the macadam construction.

PRICE PAID FOR TELFORD CONSTRUCTION.

The price paid for telford construction is to include all work and materials necessary to do the work as herein specified under telford construction.

RESURFACING.

Resurfacing the present stone road-bed is to be done wherever directed by the Engineer or provided for in the plans. The width required at different points is to be that designated by the Engineer.

ROAD-BED AND FIRST COURSE.

WIDTH AND SHAPE.

The present road-surface is to be loosened and shaped for a width of.....feet so as to present after rolling a smooth, even appearance with grades and a cross-slope of.....inch to 1 foot conforming to those shown on the plans accompanying these specifications.

## MATERIAL.

The material for this part of the work may be obtained either by loosening the present stone foundation, until sufficient material is obtained to give a proper shape, or broken stone may be used, or both, as may be necessary. The broken stone to be used for this purpose is to consist of pieces having no dimension greater than 3 inches, known as No. 1 size, and may be any sound rock, approved by the Engineer, that seems most available. It may be broken either by hand or in a crusher.

All pieces of rock loosened from the present bed of the road are to be broken to a size not exceeding 3 inches in their greatest dimension, or, if larger, such pieces may be thrown to one side and other broken stone used, but in no case are pieces of stone with a greater dimension than 3 inches to be in the reconstructed portion of the first course.

No material other than broken stone is to be used in forming the first course except as the Engineer may direct.

## ROLLING.

After the material for the first course has been brought to proper shape it is to be rolled with a steam-roller, weighing not less than ten tons, until it is compacted to form a firm and smooth surface. Should any difficulty be experienced in having the stone readily compact while rolling, sprinkling with water or lightly spreading with sand, or other material, as the Engineer may direct, shall be employed. In no instance shall broken stone for the second course be spread until the first course has been rolled as above described. The rolling must begin at the sides and work toward the center, thoroughly covering this space with the rear wheel of the roller.

## UNEVENNESS OR DEPRESSIONS.

Should any unevenness or depressions appear during or after the rolling of the first course, such unevenness or depressions are to be remedied either by removing or adding broken stone as may be required. Such places must be rolled before the material for the second course is spread.

## THICKNESS.

The first course, as formed from the present stone covering on the road as described above, is to be nowhere less than 5 inches thick.

If, for any reason, a greater thickness than specified is made by the Contractor, no extra allowance for such additional thickness will be made.

## SHOULDERS.

After the first course has been made, as herein described, earth shoulders are to be constructed along each side of the road for a width of at least.....feet, as shown on the accompanying plans.

Against these shoulders the broken stone for the second course is to be spread as herein described. The shoulders are to contain a sufficient

quantity of earth so that a smooth and continuous slope will be obtained after the shoulders and second course are rolled. The shoulders with the.....feet of stone will make a total width of.....feet to be shaped with a cross-slope of.....inch to 1 foot.

Material for the shoulders must be free from roots, stumps or other vegetable matter and thoroughly compacted by the roller. Material with a proportion of sand, such as prevents it when dry from compacting readily under the roller, is not to be used.

No material which is considered unfit for the work by the Engineer is to be used, and where any such is put on the work it shall be immediately removed, upon notice by the Engineer, at the Contractor's expense.

#### SECOND COURSE.

The second course of the resurfacing is to be the same width as the first course and made in the same manner and of similar materials as specified for the second course of macadam construction.

#### THICKNESS.

The second course of the resurfacing is to be nowhere less than 3 inches thick after thorough rolling.

If, for any reason, a greater thickness than specified is made by the Contractor, no extra allowance for such additional thickness will be made.

#### THIRD COURSE.

The third course of the resurfacing is to be made in the same way and of similar materials as specified for the third course of the macadam construction.

#### PRICE PAID FOR RESURFACING.

The price herein agreed upon to be paid for resurfacing is to include all work and materials necessary to do the work as herein specified under resurfacing.

### GENERAL CLAUSES.

#### PLANS, PROFILES AND SPECIFICATIONS.

The plans, profiles and specifications are hereby made a part of this contract, and will be held to cover any and all work that could reasonably be inferred as needed for a complete and workmanlike job. And it is understood no advantage will be taken of discrepancies found in any drawing or specification.

#### ENGINEER AS REFEREE.

It is agreed by both parties to this contract that the Engineer shall act as referee in all questions arising under the terms of this contract between the parties thereto, and that the decision of the Engineer in all such cases shall be final and binding upon both alike.



It is understood and agreed that said Engineer shall not be the paid agent of either party to this contract.

#### CHANGES IN PLANS.

The right is reserved to make such changes in the plans or specifications as may from time to time appear necessary or desirable, and such changes shall in no wise invalidate this contract. Should such changes be productive of increased cost to the Contractor a fair and equitable sum therefor, to be agreed upon before such changed work shall have been begun, shall be added to the contract price, and in like manner deductions shall be made.

#### CONTRACTOR'S LIABILITY.

The Contractor hereby assumes all risk and liabilities for accidents and damages that may accrue to persons or property during the prosecution of the work by reason of the negligence or carelessness of himself, his agents or his employees.

#### SUB-LETTING CONTRACT.

The Contractor agrees to give his personal attention to this contract and not to sub-let the same, or any portion, without written consent of the Commissioners.

#### INSTRUCTIONS TO FOREMAN.

The superintendent or foreman of any particular portion of the work shall receive and obey the instructions of the Engineer referring to that particular part of the work in case the Contractor himself is not present.

#### DUTIES OF INSPECTOR.

It shall be the duty of the Inspector to see that the provisions of this contract and specifications are fulfilled by the Contractor, and in case all the requirements of the specifications are not fulfilled to report the same immediately to the Engineer. Any instructions which the Inspector may give the Contractor shall in no wise be construed as releasing the Contractor from the proper fulfillment of the terms of this contract as determined by the Engineer. The Inspector will perform such other duties as the.....may indicate.

#### WORK BEGUN AND COMPLETED.

The work is to begin within.....days after the execution of this contract and to be diligently prosecuted to completion in such order as may be prescribed by the.....

The Contractor hereby agrees to complete the work on or before..... If the work is not completed at the date herein named the Contractor further agrees to pay to the party of the first part of this contract the



sum of.....dollars (\$.....) per day as payment for all damages to party of the first part because of the non-completion of the work on said date.

LAWS AND ORDINANCES.

The Contractor and those under him shall conduct the work in such a manner as to fulfill all the requirements of State, County or Municipal laws and ordinances applying to the work in hand, and he shall take such necessary precautions as will guard against losses of life or accident.

CLEARING UP.

The Contractor is to leave the road in a neat and presentable condition, and to remove and clear up all rubbish and surplus material.

DISORDERLY PERSONS.

Should any person employed by the Contractor appear incompetent or disorderly, he shall be immediately discharged upon request of the Engineer and shall not be employed again upon the work.

DEFINITIONS.

Whenever the word.....is used in this contract, it is understood to mean the.....for.....County, party of the first part to this contract, or their authorized representative limited by the particular duties intrusted to him.

Whenever the word "Contractor" is used, it is understood to mean the person or persons who have entered into this contract as party or parties of the second part.

Whenever the word "Inspector" is used, it is understood to mean the employee of the party of the first part to this contract, employed to perform such duties as are herein described as the duties of the Inspector.

Whenever the word "Engineer" is used, it is understood to mean .....or his authorized representative.

MEASUREMENT OF WORK DONE.

The amount of work done by the Contractor is to be measured by the Engineer, except that character of work which would require for its measurement a detailed tally of the materials as delivered on the work. In this latter case a tally is to be kept by the Inspector, who shall at the end of each day compare his tally with that of the Contractor, or foreman in charge. The Inspector shall send daily his tally, with the Contractor's or his foreman's signature, to the Engineer. Should there be a dispute between the Inspector and the Contractor as to the amounts in any particular instance, the Contractor must send immediately his account to the Engineer. It is understood and agreed that if no other tally of materials delivered, than that of the Inspector, is received by the Engineer within five days after the receipt of the Inspector's tally, the Engi-

neer's estimate shall be based upon the reports as made by the Inspector, whether or not these reports are signed by the Contractor or his foreman, and will be the basis of payment to the Contractor. Whenever a difference exists between the returns made by the Inspector and the Contractor's agent the decision of the Engineer is to be final and binding upon both parties to this contract.

ESTIMATES AND PAYMENTS.

No allowance will be made the Contractor by the Engineer in his estimates for materials that are not in place (i. e., that are not in finished portions of the work), nor will estimates be furnished for any part of the work which is in an unfinished condition except that allowance will be made for all excavation done each month.

Payments will be made by the.....to the Contractor on work done under this contract as follows:

On estimates of the work done the preceding month as furnished in writing by the Engineer, less.....per cent of such estimates which is to be retained by the.....until the completion of the whole work, when, upon certificate of said Engineer that the work has been completed in accordance with these plans and specifications, all money then due to the Contractor under this contract will be paid to him by the.....

BOND.

KNOW ALL MEN BY THESE PRESENTS:

That we.....as principal and .....as suret....., are held and firmly bound unto the.....of.....County, State of Maryland, in the sum of.....dollars (\$.....), to be paid to the said ....., or their certain attorney, their successor and assigns, for which payment well and truly to be made, we bind ourselves, our heirs, executors and administrators, jointly and severally, by these presents. Sealed with our seals and dated this.....day of.....190...

THE CONDITION OF THIS OBLIGATION IS SUCH that if said principal.....shall well and truly keep and perform all the terms and conditions of the foregoing contract for.....on.....part to be kept and performed, and shall indemnify the said.....of..... as herein stipulated, then this obligation shall have no effect, otherwise it shall remain in full force and virtue.

.....[SEAL.]  
.....[SEAL.]  
.....[SEAL.]

WITNESS:.....

PART IV

REPORT ON THE COALS OF MARYLAND

BY

WM. BULLOCK CLARK

WITH THE COLLABORATION OF

GEORGE C. MARTIN, J. J. RUTLEDGE, B. S. RANDOLPH,  
N. ALLEN STOCKTON, W. B. D. PENNIMAN  
AND ARTHUR L. BROWNE

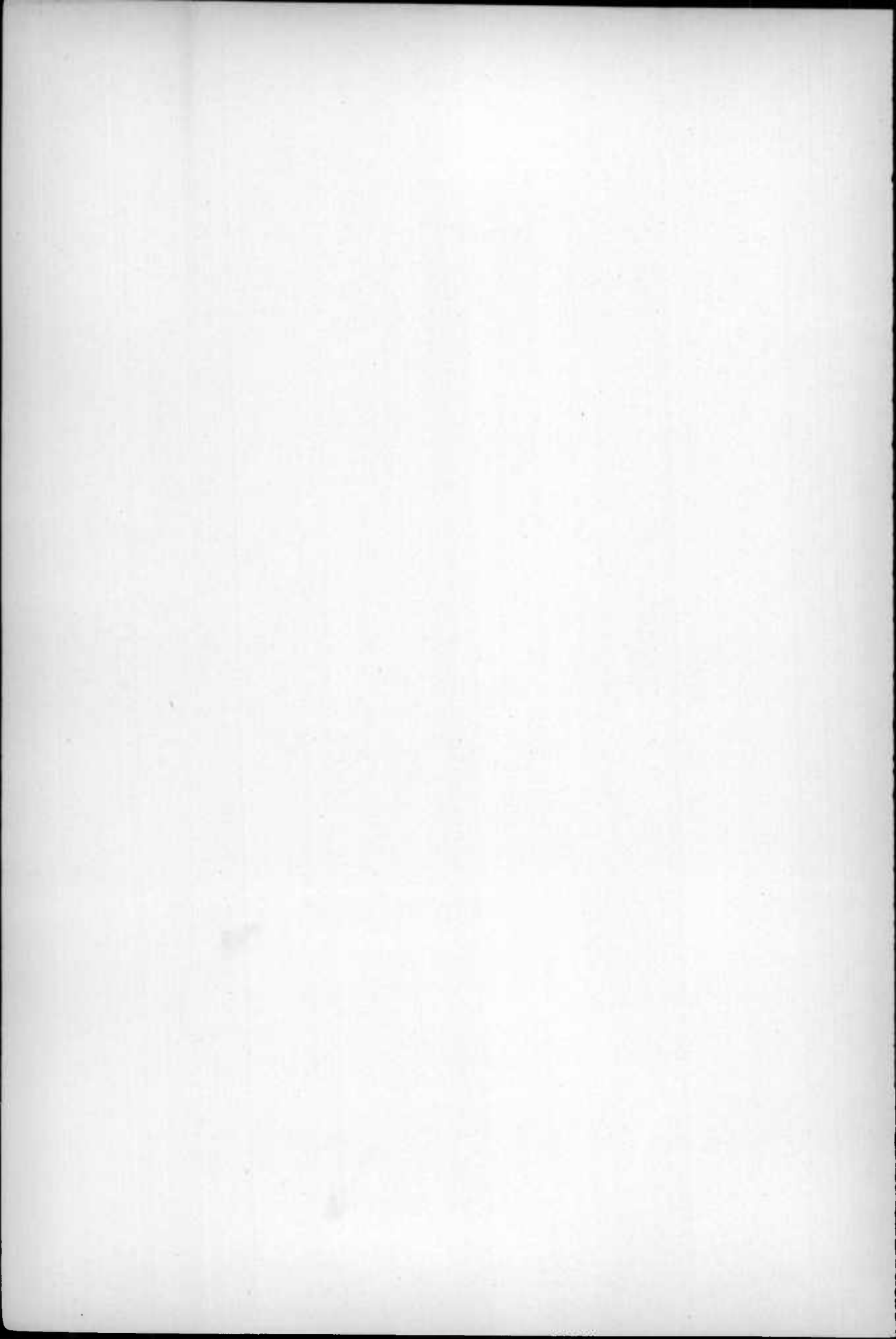

# MAP SHOWING THE DISTRIBUTION OF THE COAL MEASURES OF MARYLAND

BY  
W. B. CLARK AND G. C. MARTIN

MARYLAND GEOLOGICAL SURVEY  
WM. BULLOCK CLARK, STATE GEOLOGIST  
1902

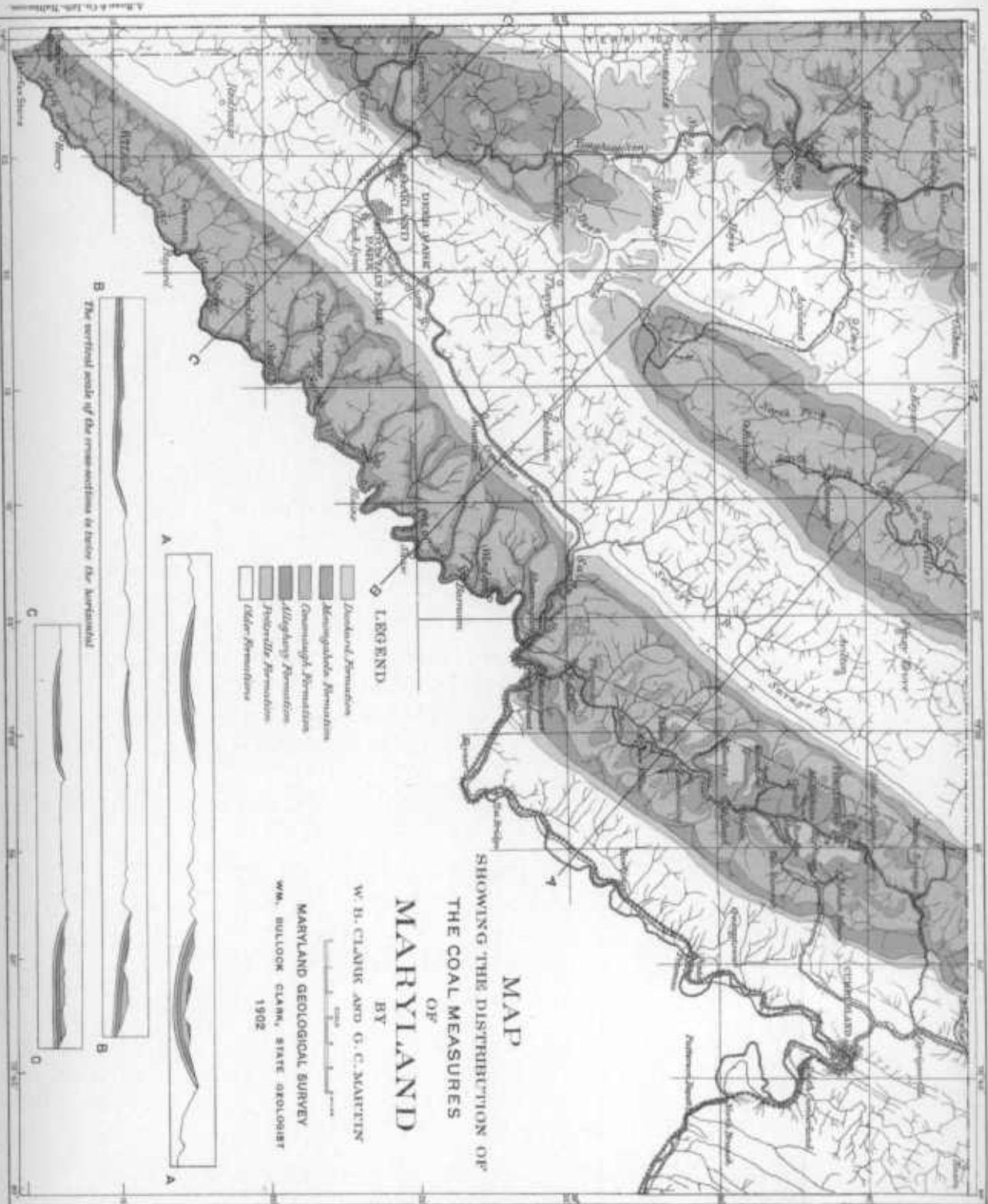

- LEGEND**
- Quaker Run Formation
  - Kensington Formation
  - Greenough Formation
  - Allegany Formation
  - Potomac Formation
  - Older Formations

A, B, C, D  
The vertical scale of the cross-sections is twice the horizontal

A. B. Clark & Co., Inc., Baltimore

R120

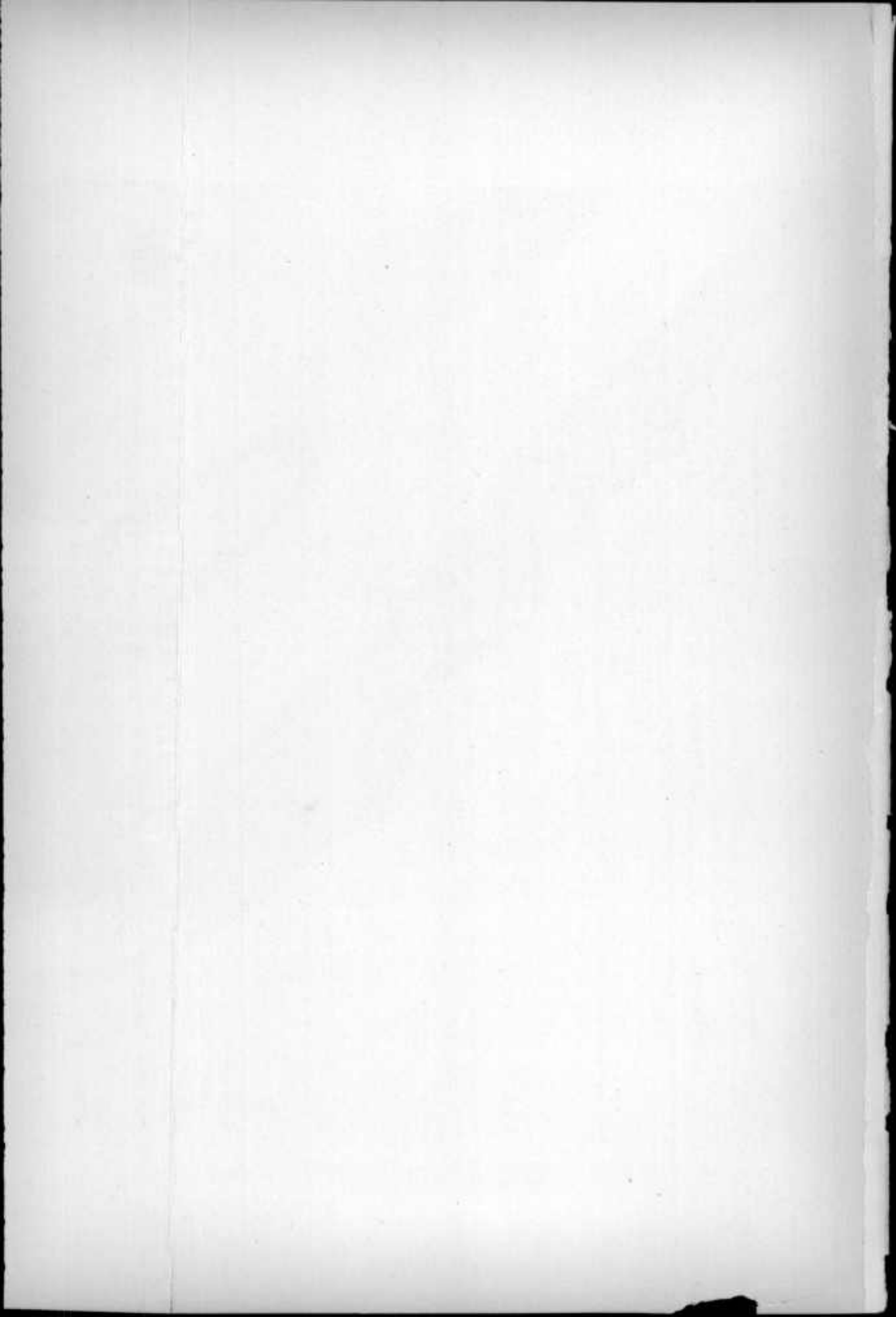

# ORIGIN, DISTRIBUTION AND USES OF COAL

BY

WM. BULLOCK CLARK

---

## INTRODUCTION

The coal deposits of Maryland are confined to the western part of the State where for more than half a century they have afforded the basis of the most important mineral industry in Maryland. They have been studied by geologists since the early days of geological investigation in Maryland and a copious literature has resulted in which both the geological and economic conditions have been extensively discussed. The proximity of the coal areas of western Maryland to those of Pennsylvania on the north and of West Virginia on the south and west has likewise led to the incorporation of the Maryland district in the discussions of those two regions, and a study of the geological literature of those states will, therefore, afford much information regarding the coal deposits of Maryland. Many of the names employed for the formations and coal seams of Maryland have, moreover, been proposed by the geologists of these neighboring commonwealths, while, on the other hand, the great economic importance of the Georges Creek basin and its early study led in some instances to the employment of terms there which have likewise been adopted in neighboring areas. The relations of the Maryland deposits to those of adjacent states will accordingly form an important chapter in the discussion which follows.

No question has more fully occupied the attention of the present State Geological Survey than the coal deposits of Allegany and Gar-

rett counties, both on account of their present commercial importance and the possibility of their greatly increased development in areas that are at present unworked. Maps of the geology showing the several formations and their contained coal beds have been prepared on a large scale and have already been issued in the volumes dealing with Allegany and Garrett counties. Less attention will be paid to the geological features in the present paper, most of the report being devoted to the distribution, character, and availability of the coal beds.

#### HISTORY OF THE USE OF COAL.

The use of coal dates back to the very earliest times although its consumption in large amounts covers only a short period. The Chinese made use of coal in the far distant past and the people inhabiting the northern shores of the Mediterranean also employed it from the earliest period of recorded history, Greek literature as early as the fourth century B. C. containing accounts of its properties. The ancient Britons were also using coal at the time of the Roman invasion. From these early periods the importance of coal as a fuel, even for simple metallurgical, smithing, and domestic purposes, came to be but slowly recognized until the invention of the steam engine in the middle of the eighteenth century brought about a greatly increased use of coal which has advanced with rapid strides, until to-day coal is the greatest single factor in the industrial life of the world.

Although it seems probable that the existence of coal in America was known to the Indians before the advent of the whites, yet the first authentic use of it for commercial purposes dates from the year 1769 when a blacksmith in Pennsylvania employed anthracite for fuel in his forge. Notwithstanding this and other local uses of coal in the anthracite region the beginning of the Pennsylvania coal trade only dates from 1807 when the first regular shipments of coal began on the Susquehanna river. By 1820 this had materially increased and from that time on, down to the present day, the anthracite coal



trade has had a rapid development. Great difficulty was encountered in earlier years in making people believe that mineral coal could be successfully used as fuel and the earliest shippers of Pennsylvania anthracite accompanied their shipments, taking grates which were set up in public houses to demonstrate the use and value of this fuel.

The use of bituminous coal also dates from the latter part of the eighteenth century, a coal mine being reported as opened in the vicinity of what is now the city of Pittsburg even earlier than the date of the first authentic use of anthracite, but no reliable records regarding it can be secured. It is known, however, that after 1794 when the first steam engine was employed in Pittsburg the demand for bituminous coal increased and that within a few years a number of mines had already been opened in the region. Bituminous coal was not employed to any extent for industrial purposes, however, until about 1825, in which year it is reported that about 3500 tons of coal were used in the vicinity of Pittsburg. From that time on the soft coal output has increased rapidly until it now surpasses the anthracite. The Northern Appalachian coal field from its proximity to the great manufacturing centers has always been the most important bituminous coal field in the United States.

Although coal was discovered near Frostburg at least as early as 1782,<sup>1</sup> the first eastern shipments from the Maryland coal district were not made, so far as known, until 1820, when small amounts were transported by barges down the Potomac river. Since the construction of the Baltimore and Ohio Railroad in 1842 and of the Chesapeake and Ohio Canal in 1850, the output from the Maryland mines has very rapidly increased and numerous companies are now engaged in the mining of coal in Maryland.

The development of the southern Appalachian coal field dates from a later period than the northern Appalachian field, although coal was mined in the Birmingham district as early as 1836. It was not,

<sup>1</sup> Carte générale des Treize Etats Unis et Indépendants de l'Amérique Septentrionale d'après M. Bonne, 1782, shows a "Mine de Charbon" at the mouth of Georges Creek.

however, until after the close of the Civil War that the great importance of this district became apparent.

Of more importance even than the anthracite and bituminous coals of Carboniferous age in the eastern states in these early days were the Triassic coals of the Richmond basin in Virginia which until the late thirties were more extensively mined than any other coal beds of the United States with the exception of the anthracite coals of Pennsylvania. Even as early as 1789 shipments had been made from this region to northern cities. This field is, however, of relatively small importance at the present day compared with the great areas of Carboniferous coal to the westward.

The coal fields west of the Alleghanies were much later in development than those of the eastern fields, although the bituminous coal of the interior region was already mined to some extent during the decade from 1830 to 1840. Considerable shipments were made down the Ohio river soon after 1840, and from that time on the importance of the coal deposits of the interior became more and more marked as the region became more fully settled.

The development of coal on the Pacific coast was of still more recent date, the industry attaining little importance until after 1860, when coal began to be shipped in considerable quantities to San Francisco and other points from mines in California, Oregon, and Washington. The development of the coal industry on the Pacific coast has encountered many vicissitudes because of the many difficulties encountered in the mining operations.

#### ORIGIN OF COAL.

Coal is formed from vegetable débris. This is shown from the chemical composition of the materials and their association with definitely recognizable roots, trunks, branches, and leaves of a character typical of the period when the coal deposits were laid down. The state of preservation of the plant remains depends to a considerable extent on the stage of alteration of the materials, although the organic structure is generally entirely obliterated in the main body of all coal

seams. Plant remains are generally present, however, in the shales and clays overlying and underlying the coal bed, and it is not uncommon to find the layers beneath the coal penetrated by rootlets which branch in all directions as in the soils and subsoils of the present day. At times these adjacent beds afford vast numbers of determinable plant remains in which the most delicate structures are preserved. In this way paleontologists have been able to show the character of the forests of the period of coal formation and even to describe the accompanying insect life, caught in the exuding gum of the trees.

Every gradation from unaltered vegetable débris through peat, lignite, bituminous coal, semi-bituminous coal, semi-anthracite, anthracite, graphitic anthracite to graphite may be found and there is every reason to believe that all of these materials have had a common origin, although their method of accumulation may have varied in different localities.

Two views have been advanced to account for the deposition of vegetable débris in sufficiently large quantities to produce beds of coal. By the first its origin would be explained through the growth and burial of the material in the place where it is now found; by the second through the transportation of the material by stream and shore currents from the nearby land of the period, and its deposition in shallow waters not far from shore, like other sediments.

By those holding the first view coal deposits have been compared to sphagnous or peat-like accumulations in marshes, or cypress and mangrove swamps which have gradually spread along low shore-lines for great distances and through slow subsidence been buried and protected by muddy and sandy sediments. As coal deposits are often found at successive horizons through a thickness of thousands of feet, the same conditions of plant accumulations must necessarily have persisted throughout the entire period, with the exception of longer or shorter interruptions when the muddy and sandy beds were laid down. By those holding this view it is considered impossible on any other grounds to account for the existence of vertical tree trunks with their roots branching in the soil in which they evidently lived.

A succession of sixty-eight such forest growths has been described by Dawson in the Carboniferous strata of Nova Scotia.

By those holding the view that coal seams have been formed from vegetable débris derived from the adjacent land, no other explanation is considered possible for the stratified character of so many coals, with their shale and clay partings. The gradual change at times of coal beds laterally into shaly and even sandy deposits is also considered evidence of their origin in this way. Furthermore, the very homogeneous and almost structureless character of many coals is cited, and the fact that the calcium sulphate of sea-water could readily reduce vegetable débris to a pulp-like mass destroying all plant structure. The existence also at times of marine organisms in deposits interstratified with the coal beds is likewise introduced to support the interpretation that the coal was formed in such cases in waters open to the sea and in a manner similar to other sediments.

In the light of this more or less conflicting evidence it seems more than probable that both processes have been in operation and that some coal beds have been formed *in situ* as first described, while others have accumulated in shallow waters like other sediments. Only in this way can all the phenomena be satisfactorily explained.

Many suggestions have been made regarding the climate during the period of formation of such extensive deposits of vegetable débris as characterize the Carboniferous and Cretaceous periods. Some have advanced the view that the amount of carbon dioxide in the atmosphere must have been far greater than at the present time. It is quite possible that there has been a diminution of this gas in the atmosphere in later geological periods but it seems hardly probable that the amount at the close of the Paleozoic could have been greatly in excess of that now prevailing since even in the Carboniferous period there were numerous air-breathing animals such as the labyrinthodonts and the insects which could hardly have existed in an atmosphere very different from that of the present day.

The suggestion that the climate must have been much warmer to account for such a luxuriant growth of coal-producing plants is like-

wise difficult of acceptance when there is the best of evidence of the existence of glaciers in Carboniferous time even within the limits of the present tropical zone. It seems probable, however, that the climate was in general moist since the flora of the period spread widely over the land areas of the globe, extending even into arctic latitudes.

The enormous thickness of the accumulation of vegetable débris may be appreciated when it is known that not less than seven feet of closely compacted vegetable débris is necessary to produce a foot of bituminous coal, and that ten feet of similar material is required to produce one foot of anthracite coal. The great Mammoth seam of the anthracite region of Pennsylvania which frequently has a thickness of 30 feet would thus require 300 feet of closely compacted vegetable débris for its formation.

Reference has been made above to the deposits associated with coal beds. In every region a certain definite association has been commonly found to occur, although exceptions to the rule are not infrequent. In general the coal deposit rests upon a bed of clay which on account of the low percentage of the alkalies has an important economic value as a fire-clay. Overlying the coal there is commonly a dark, more or less bituminous, shale, which in turn may be succeeded either by a lighter colored shale or sandstone. The underlying bed is the soil upon which the coal flora grew and from which the alkalies were extracted by the growing plants while the overlying beds are the materials which under varying conditions were deposited upon and preserved the accumulated vegetable débris. Less frequently limestones and dolomites are found associated with the other deposits, depending upon whether the area became depressed sufficiently to produce open waters, with little or no transportation of muddy and sandy sediments.

#### GEOLOGICAL AGE OF COAL.

Coal deposits of economic value have been found at all geological horizons from the Devonian to the Recent. The most important beds are of Carboniferous, Triassic, Cretaceous, and Tertiary age.

Among these the Carboniferous coals have been much more extensively developed than those of later date. The most important coal deposits of central and eastern North America, of Europe, and of Australia are of Carboniferous age. To this horizon belong all of the Maryland coals.

#### DISTRIBUTION AND PRODUCTION OF COAL.

Coal is found on every continent. The chief sources of coal at the present day are in central and eastern North America, in the United States and Nova Scotia; in central and southern continental Europe and England; in eastern Australia; and in eastern and southern Asia, in Japan and India. Coal is also known to occur in South America and Africa. Its extent even in the countries where it has been most extensively developed is not fully established and the known areas of its distribution are being yearly extended as the industrial demands increase.

The following table<sup>1</sup> shows the total amount of coal produced in the various countries of the globe from the latest statistical returns.

The production by the United States as shown by this table is somewhat more than one-third of the entire coal output of the world and now exceeds that of Great Britain, which it for the first time surpassed in 1899. Since that year the United States has maintained a steady increase in production over that of Great Britain. After 1877 the United States permanently displaced Germany, which in that year had a somewhat larger output than this country. In 1880 the percentage of Great Britain was 2.3 times that of the United States and in 1890 1.4 times. During the last 35 years the coal production of the United States has increased 852% while that of Great Britain has increased only 120%, and Germany 218%.

<sup>1</sup> This table was compiled by the U. S. Geological Survey from the latest records.

## THE WORLD'S PRODUCTION OF COAL.

Country.	Usual unit in producing country.	Equivalent in short tons.
United States (1903) .....	long tons <sup>1</sup> . 319,068,229	357,356,416
Great Britain (1903).....	do..... 230,334,469	257,974,605
Germany (1903) .....	metric tons <sup>1</sup> . 162,312,075	178,916,600
Austria-Hungary (1902) .....	do..... 39,479,560	43,518,319
France (1903) .....	do..... 35,002,992	38,583,798
Belgium (1903) .....	do..... 23,870,820	26,312,805
Russia (1902) .....	long tons.. 15,259,674	17,090,835
Japan (1901) .....	metric tons.. 8,945,938	9,861,107
Canada (1903) .....	short tons <sup>1</sup> . 7,996,634	7,996,634
India (1902).....	long tons.. 7,424,480	8,315,418
New South Wales (1902).....	do..... 5,942,011	6,655,052
Spain (1903).....	metric tons.. 2,798,113	3,084,360
South African Republic (1902).....	long tons.. 1,590,330	1,781,170
New Zealand (1902).....	do..... 1,362,702	1,526,226
Mexico (1902).....	metric tons.. 710,000	782,633
Sweden (1902) .....	do..... 304,733	335,907
Italy (1902) .....	do..... 413,810	456,143
Holland (1902) .....	do..... 399,133	439,964
Queensland (1902).....	long tons.. 501,531	561,715
Victoria (1902) .....	do..... 225,164	252,184
Natal (1902) .....	do..... 592,821	663,960
Cape Colony (1902).....	do..... 165,557	185,424
Tasmania (1902) .....	do..... 48,863	54,727
Other countries <sup>2</sup> .....	do..... 4,600,361	5,152,404
Total.....	.....	967,858,406
Percentage of the United States.....	.....	37

<sup>1</sup> A long or gross ton equals 2240 pounds; a metric ton 2204.6 pounds, and a short ton 2000 pounds.

<sup>2</sup> Includes China, Turkey, Servia, Portugal, United States of Colombia, Chile, Borneo and Labuan, Peru, Greece, etc.

Coal is found in more than half of the states and territories of the United States. The position of these areas is shown on the accompanying map (Plate XIV). The Carboniferous and Triassic coals are found to the east of the one hundredth meridian, the Triassic coals being confined to small areas near the Atlantic coast. The Cretaceous coals occur between the one hundredth and one hundred and fifteenth meridians, in the Rocky Mountain region. The Tertiary coals lie to the west of the one hundred and twentieth meri-

dian along the Pacific coast. The relative importance of these areas at the present time may be judged from the production of coal in 1903. In that year the production of the Carboniferous coals amounted to 262,270,236 tons, of Triassic coals to 35,393 tons, of Cretaceous coals to 17,053,790 tons, and of Tertiary coals to 3,389,837 tons. This production does not, however, coincide with the extent of known coal-bearing formations in the several areas as will be seen from the following figures: the total Carboniferous areas have been estimated by the U. S. Geological Survey to amount to 234,667 square miles, of Triassic to 1070 square miles, of Cretaceous to 143,720 (including lignite 100,110), and Tertiary to 1050 square miles. In this estimate the areas of lignite coal of Tertiary age are not included. They are estimated to cover approximately 56,500 square miles along the Gulf border in Alabama, Mississippi, Louisiana, Arkansas, and Texas, but they have small economic value at the present time. All of these figures are regarded as only approximate since areas now considered as unproductive may, under different conditions, come to have commercial value. For example, many of the deep-lying coals are not included in the above estimate.

## THE PRODUCTION OF COAL IN THE UNITED STATES IN 1903.

CARBONIFEROUS COALS.		Area in sq. miles.	Production in short tons.
<i>Anthracite.</i>			
Anthracite field, Pennsylvania.....		484	74,607,068
<i>Bituminous and Semi-bituminous.</i>			
Northern Appalachian field:			
Pennsylvania .....		15,800	103,117,176
Ohio .....		12,000	24,838,103
Maryland .....		510	4,846,165
Virginia .....		1,850	3,433,233
West Virginia .....		17,280	29,337,241
Eastern Kentucky .....		10,300	3,158,972
		57,740	168,730,890
Southern Appalachian field:			
Tennessee .....		4,400	4,798,004
Georgia .....		167	416,951
Alabama .....		8,500	11,654,324
		13,067	16,869,279



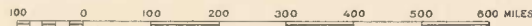
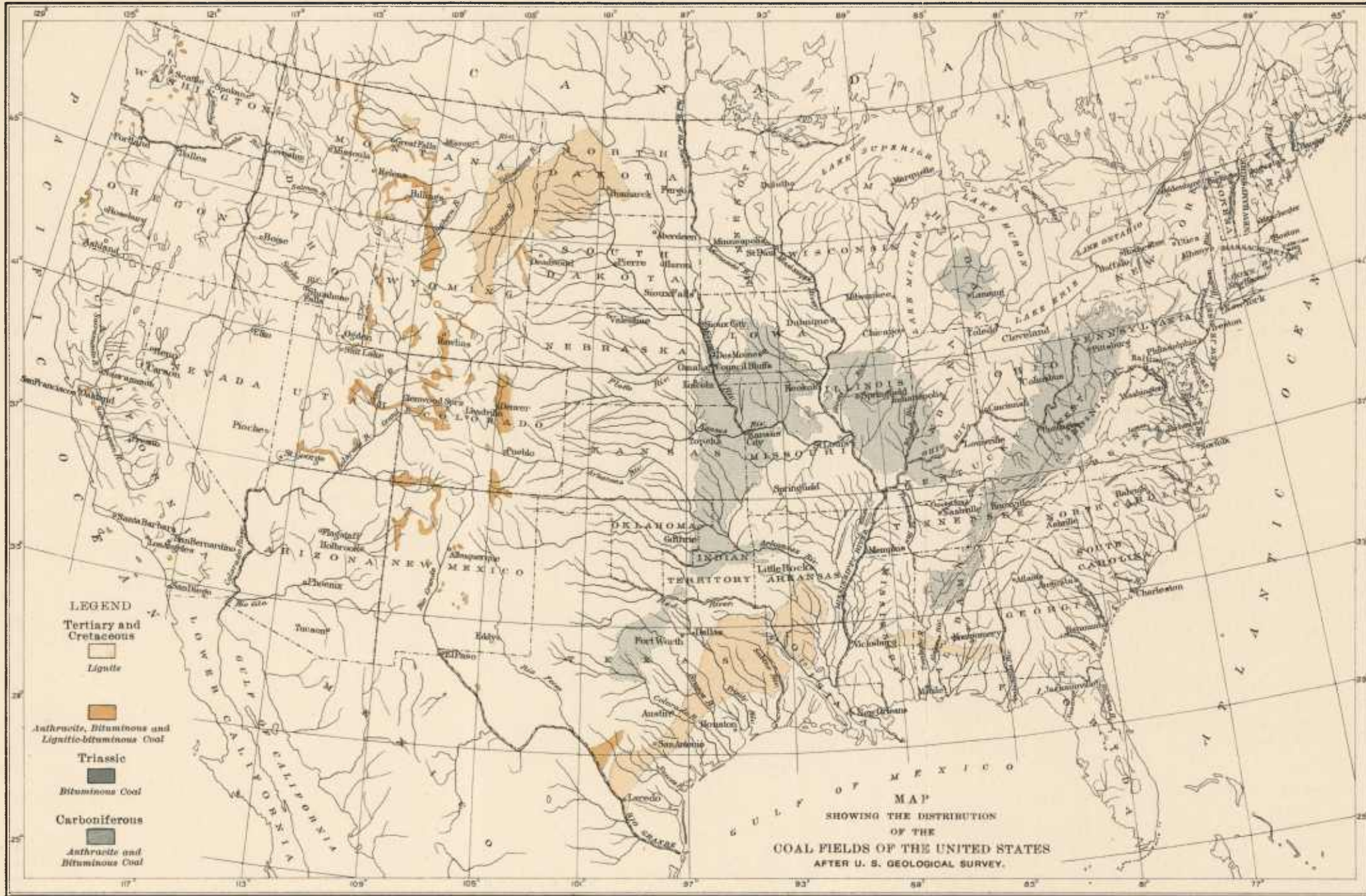

A. ROBEY & CO. BALTIMORE

P230 B

THE PRODUCTION OF COAL IN THE UNITED STATES IN 1903.—*Continued.*

CARBONIFEROUS COALS.	Area in sq. miles.	Production in short tons.
<i>Bituminous and Semi-bituminous.</i>		
Northern Interior field:		
Michigan .....	11,300	1,367,619
Central Interior field:		
Indiana .....	9,300	10,794,692
Western Kentucky .....	5,800	4,379,060
Illinois .....	42,900	36,957,104
	58,000	52,130,856
Western Interior field:		
Iowa .....	20,000	6,419,811
Missouri .....	23,000	4,238,586
Nebraska .....	3,200	.....
Kansas .....	20,000	5,839,976
Arkansas .....	1,728	2,229,172
Indian Territory .....	14,848	3,517,388
Texas .....	11,300	926,759
	94,076	23,171,692
TRIASSIC COALS.		
Atlantic Coast field:		
<i>Bituminous, etc.</i>		
Virginia .....	270	18,084
North Carolina .....	800	17,309
	1,070	35,393
CRETACEOUS COALS.		
Rocky Mountain field:		
<i>Anthracite.</i>		
Colorado and New Mexico.....	16	72,731
<i>Bituminous, lignite, etc.</i>		
North Dakota .....	28,620	278,645
Montana .....	32,000	1,488,810
Wyoming .....	16,500	4,635,293
Utah .....	2,000	1,681,409
Colorado .....	18,100	7,381,463
New Mexico .....	2,890	1,511,189
Idaho .....	.....	4,250
Nevada .....	.....	.....
	100,110	16,981,059

THE PRODUCTION OF COAL IN THE UNITED STATES IN 1903.—*Continued.*

TERTIARY COALS.		Area in sq. miles.	Production in short tons.
Pacific Coast fields:			
<i>Bituminous, etc.</i>			
Washington .....	450	3,193,273	
Oregon .....	320	91,144	
California .....	280	104,673	
Alaska .....	.....	747	
	1,050	3,389,837	
Total production including colliery consumption....			357,356,416

Still other factors than their areal extent have to be considered in determining the importance of coal deposits. Among these may be mentioned the proximity of the coal to market and the ease with which it can be transported. The quality of the coal is also an important matter, as well as the cost of mining, the latter depending upon the character of the coal, its attitude and position, the thickness of the seam, and the number of beds which can be reached by the same operation.

## THE APPALACHIAN COAL FIELD.

The Appalachian coal field, which includes the Maryland coal deposits, extends from northern Pennsylvania to central Alabama, a distance of about 800 miles. It embraces parts of the states of Pennsylvania, Ohio, West Virginia, Maryland, Virginia, Kentucky, Tennessee, Georgia, and Alabama. Excluding the Carboniferous anthracite field of eastern Pennsylvania, which is estimated to contain a productive area of 484 square miles, the Appalachian field proper embraces 70,807 square miles, 75 per cent of which is regarded as productive. The Appalachian coal field is over 175 miles in width in the north, gradually narrowing southward until it is less than 20 miles wide in Tennessee, beyond which it again expands to a width of over 75 miles in Alabama.

The total output of the Appalachian field in 1903 amounted to 185,600,119 tons of coal, the adjoining anthracite field during the



same year producing in addition 74,607,068 tons.<sup>1</sup> The relation of this eastern field to the great interior Carboniferous fields which cover more than twice the area may be seen by the fact that the production in the latter region in the same year amounted to only 76,670,167 tons.

The Appalachian coal field is by far the most important of the coal fields of the United States. Not only is its production greater than that of any other area, but its location renders it much more available to the great eastern industrial markets. It has many workable beds and on account of the demand for the coal these have been much more highly developed and their areal extent much more definitely determined than in any of the other districts, with the exception of the adjoining anthracite field, which, although separated to-day and containing coal of so different a character, is yet geologically part of the same great basin.

The Appalachian field presents certain general structural features that bear a direct relationship to the character of the coals. Along the eastern margin the rocks are frequently considerably folded, the coal lying in long synclinal troughs that are parallel to the general structure of the Appalachian belt, while to the westward these folds gradually flatten out until along the western margin of the field the beds lie nearly horizontal. As a result of this increased folding eastward the coals have become metamorphosed through heat and pressure after they were buried and contain a gradually higher percentage of fixed carbon with a correspondingly less amount of volatile carbon. The coals in consequence change gradually from the soft bituminous varieties to the semi-bituminous and these in turn to hard anthracites in the highly folded basins of Pennsylvania and Virginia to the east of the main Appalachian belt.<sup>2</sup> In general the coal deposits are thickest along the eastern margin of the field and gradually thin west-

<sup>1</sup>The output was reduced during 1902 on account of the anthracite coal strike. It was 67,471,667 tons in 1901, and only 41,373,595 in 1902.

<sup>2</sup>Professor J. J. Stevenson claims that anthracite coal is produced not by metamorphism, but by the longer exposure of this coal to the action of percolating water before final burial and consolidation of the rocks, whereby the volatile constituents were removed.

ward. Many of the coal beds can be traced continuously over thousands of square miles, while others have only a local development. It is, therefore, necessary to observe care in establishing correlations of the beds in distant and disconnected areas, although the fossils frequently prove sufficiently characteristic to determine the various horizons.

The *northern* Appalachian field, on account of its proximity to the great centers of consumption, has up to the present time been much more extensively developed than the *southern* field. Its production in 1903 was 168,730,890 tons as against 16,869,279 tons in the southern field. Notwithstanding the extensive development of the northern field there are still considerable areas distant from the lines of transportation that have not yet been fully explored. Further study is constantly bringing to light new regions, and railroads are being extended into these new districts.

The accompanying map (Plate XV) shows the areal extent of the northern field together with the important lines of transportation which enter it. Both the upper and lower coals are represented. The lower coals pass beneath the area of the upper beds and thus occupy the entire coal district. This northern field covers an area of 57,740 square miles, and has developed with marvelous rapidity as will be seen by comparing its total output during the decades from 1850 on.

TABLE SHOWING PRODUCTION OF COAL IN NORTHERN APPALACHIAN FIELD.

1850.....	1,882,517	1890.....	66,293,157
1860.....	4,730,546	1900.....	130,078,814
1870.....	13,712,856	1902.....	158,123,240
1880.....	32,869,211	1903.....	168,730,890

In 1870 the output of the anthracite field exceeded that of the northern Appalachian bituminous field by nearly 3,000,000 tons, but in 1880 the bituminous field had surpassed the anthracite by somewhat over 4,000,000 tons, and since that date the difference between them has steadily been growing greater until the bituminous field at the present time produces more than twice the tonnage of the anthracite field. This disparity will unquestionably be still more marked as time goes on.

PRODUCTION OF COAL IN NORTHERN APPALACHIAN AND ANTHRACITE FIELDS FROM 1814 TO 1904.

Year.	Bituminous and Semi-bituminous						Anthracite	
	Pennsylvania.	Maryland.	Virginia.	West Virginia.	Ohio.	Eastern Kentucky.	Total.	Pennsylvania.
1814	.....	.....	.....	.....	.....	.....	.....	22
1815	.....	.....	.....	.....	.....	.....	.....	50
1816	.....	.....	.....	.....	.....	.....	.....	75
1817	.....	.....	.....	.....	.....	.....	.....	100
1818	.....	.....	.....	.....	.....	.....	.....	200
1819	.....	.....	.....	.....	.....	.....	.....	350
1820	.....	.....	.....	.....	.....	.....	.....	450
1821	.....	.....	.....	.....	.....	.....	.....	1,322
1822	.....	.....	54,000	.....	.....	.....	54,000	4,583
1823	.....	.....	60,000	.....	.....	.....	60,000	8,563
1824	.....	.....	67,040	.....	.....	.....	67,040	13,685
1825	.....	.....	75,000	.....	.....	.....	75,000	42,988
1826	.....	.....	88,720	.....	.....	.....	88,720	59,194
1827	.....	.....	94,000	.....	.....	.....	94,000	78,151
1828	.....	.....	100,080	.....	.....	.....	100,080	95,500
1829	.....	.....	100,000	.....	.....	.....	100,000	138,086
1830	.....	.....	102,800	.....	.....	.....	102,800	215,272
1831	.....	.....	118,000	.....	.....	.....	118,000	217,842
1832	.....	.....	132,000	.....	.....	.....	132,000	447,550
1833	.....	.....	125,000	.....	.....	.....	125,000	600,907
1834	.....	.....	124,000	.....	.....	.....	124,000	464,015
1835	.....	.....	120,000	.....	.....	.....	120,000	690,854
1836	.....	.....	124,000	.....	.....	.....	124,000	842,832
1837	.....	.....	160,000	.....	.....	.....	160,000	1,071,151
1838	.....	.....	300,000	.....	119,952	.....	419,952	910,075
1839	.....	.....	396,000	.....	125,000	.....	521,000	1,008,322
1840	464,826	.....	424,894	.....	140,536	.....	1,030,256	967,108
1841	475,000	.....	379,600	.....	160,000	.....	1,014,600	1,182,441
1842	500,000	2,104	373,640	.....	225,000	.....	1,100,744	1,365,563
1843	650,000	12,421	370,000	.....	280,000	.....	1,312,421	1,556,753
1844	675,000	18,345	365,000	.....	340,000	.....	1,398,345	2,009,207
1845	700,000	30,372	350,000	.....	390,000	.....	1,470,372	2,480,032

PRODUCTION OF COAL IN NORTHERN APPALACHIAN AND ANTHRACITE FIELDS FROM 1814 TO 1904.—Continued.

Year.	Bituminous and Semi-bituminous							Anthracite	
	Pennsylvania.	Maryland.	Virginia.	West Virginia.	Ohio.	Eastern Kentucky.	Total.	Pennsylvania.	Total.
1846	760,000	36,707	340,000	.....	420,000	.....	1,556,707	2,887,815	4,443,522
1847	399,840	65,222	325,000	.....	480,000	.....	1,270,062	3,551,005	4,821,067
1848	500,000	98,032	318,000	.....	540,000	.....	1,456,032	3,805,342	5,261,374
1849	750,000	175,497	315,000	.....	600,000	.....	1,840,497	3,995,334	5,835,831
1850	1,000,000	242,517	310,000	.....	640,000	.....	2,192,517	4,138,164	6,330,681
1851	1,200,000	317,460	310,000	.....	670,000	.....	2,497,460	5,481,065	7,978,525
1852	1,400,000	411,707	325,000	.....	700,000	.....	2,836,707	6,151,957	8,988,664
1853	1,500,000	657,862	350,000	.....	760,000	.....	3,267,862	6,400,426	9,668,288
1854	1,650,000	812,727	370,000	.....	800,000	.....	3,632,727	7,394,875	11,027,602
1855	1,780,000	735,137	380,782	.....	890,000	.....	3,785,919	8,141,754	11,927,673
1856	1,850,000	817,659	352,687	.....	930,000	.....	3,950,346	8,534,779	12,485,125
1857	2,000,000	654,017	363,605	.....	975,000	.....	3,992,622	8,186,567	12,179,189
1858	2,200,000	722,686	377,690	.....	1,000,000	.....	4,300,376	8,426,102	12,726,478
1859	2,400,000	833,349	359,055	.....	1,060,000	.....	4,652,404	9,619,771	14,272,175
1860	2,690,786	438,000	473,360	.....	1,265,600	.....	4,867,746	8,115,842	13,043,592
1861	3,200,000	287,073	445,165	.....	1,150,000	.....	5,082,238	9,799,654	14,881,892
1862	4,000,000	346,201	445,124	.....	1,200,000	.....	5,991,325	9,695,110	15,686,435
1863	5,000,000	877,313	40,000	.....	1,204,581	.....	7,566,542	11,785,320	19,351,862
1864	5,839,000	755,764	40,000	454,888	1,815,622	.....	8,905,274	12,538,649	21,443,923
1865	6,350,000	1,025,208	40,000	487,897	1,536,218	.....	9,439,323	11,891,746	21,331,069
1866	6,800,000	1,217,668	40,000	512,068	1,887,424	.....	10,457,160	15,651,183	26,108,343
1867	7,300,000	1,381,429	50,000	589,360	2,092,334	.....	11,413,123	16,002,109	27,415,232
1868	7,500,000	1,529,879	59,051	609,227	2,475,844	.....	12,174,001	17,003,405	29,177,406
1869	6,750,000	2,216,300	65,000	603,148	2,461,986	.....	12,096,434	17,083,134	29,179,568
1870	7,798,518	1,819,824	61,803	608,878	2,527,285	.....	12,816,308	15,664,275	28,480,583
1871	9,040,565	2,670,338	70,000	618,830	4,000,000	.....	16,399,733	19,342,057	35,741,790
1872	11,695,040	2,647,156	69,440	700,000	5,315,294	.....	20,426,930	24,233,166	44,660,096
1873	13,098,829	3,198,911	67,200	1,000,000	4,550,028	.....	21,914,968	26,152,837	48,067,805
1874	12,320,000	2,899,392	70,000	1,120,000	3,267,585	.....	19,676,977	24,818,790	44,495,767
1875	11,760,000	2,808,018	60,000	1,120,000	4,864,259	.....	20,612,277	22,485,766	43,098,043

PRODUCTION OF COAL IN NORTHERN APPALACHIAN AND ANTHRACITE FIELDS FROM 1814 TO 1904. — Continued.

Year.	Bituminous and Semi-bituminous.							Anthracite	
	Pennsylvania.	Maryland.	Virginia.	West Vir- ginia.	Ohio.	Eastern Kentucky.	Total.	Pennsyl- vania.	
1876	12,880,000	2,126,873	55,000	896,000	3,500,000	.....	19,457,673	22,793,245	
1877	14,000,000	1,939,575	50,000	1,120,000	5,250,000	.....	22,359,575	25,660,316	
1878	15,120,000	2,068,325	50,000	1,120,000	5,500,000	.....	20,858,925	21,689,682	
1879	16,240,000	2,132,233	45,000	1,400,000	6,000,000	.....	25,817,233	30,207,793	
1880	18,425,163	2,228,917	43,079	1,829,844	6,008,595	310,990	28,846,588	28,649,812	
1881	22,400,000	2,533,348	50,000	1,680,000	9,240,000	295,719	36,199,067	31,920,018	
1882	24,640,000	1,555,445	112,000	2,240,000	9,450,000	539,700	38,537,145	35,121,256	
1883	26,880,000	2,476,075	252,000	2,325,833	8,229,439	627,257	40,800,594	38,456,845	
1884	28,000,000	2,765,617	336,000	3,360,000	7,640,062	674,400	42,776,079	37,156,847	
1885	26,000,000	2,833,337	567,000	3,369,062	7,816,179	736,595	41,322,173	38,335,974	
1886	27,094,501	2,517,577	684,951	4,005,796	8,435,211	706,757	43,444,793	39,035,446	
1887	31,516,856	3,278,023	825,263	4,881,620	10,300,708	950,903	51,753,373	42,088,197	
1888	33,796,727	3,479,470	1,073,000	5,498,800	10,910,951	1,105,872	55,864,820	46,619,564	
1889	36,174,089	2,939,715	865,786	6,231,880	9,976,787	1,035,858	57,224,115	45,546,970	
1890	42,302,173	3,357,813	784,011	7,394,654	11,494,506	1,183,347	66,516,504	46,468,641	
1891	42,788,490	3,820,239	736,399	9,220,665	12,868,883	1,315,646	70,750,122	50,665,431	
1892	46,694,576	3,419,962	675,205	9,738,755	13,562,927	1,292,648	75,384,073	52,472,504	
1893	44,070,724	3,716,941	820,339	10,708,578	13,253,646	1,502,458	74,071,786	53,967,543	
1894	39,912,463	3,501,428	1,229,083	11,627,757	11,909,856	1,150,229	69,330,816	51,921,121	
1895	50,217,228	3,915,585	1,368,324	11,387,961	13,555,806	1,423,492	81,668,396	57,999,337	
1896	49,557,453	4,143,936	1,254,723	12,876,296	12,875,202	1,421,017	82,128,627	54,346,081	
1897	54,417,974	4,442,128	1,528,302	14,248,159	12,196,942	1,189,482	88,022,987	52,611,680	
1898	65,165,133	4,674,884	1,815,274	16,700,999	14,516,867	1,471,061	104,344,218	53,382,644	
1899	74,150,175	4,807,396	2,105,791	19,252,995	16,500,270	1,764,874	118,581,501	60,418,005	
1900	79,842,326	4,024,688	2,393,754	22,647,207	18,988,150	2,087,277	129,983,402	57,367,915	
1901	82,305,946	5,113,127	2,725,873	24,068,402	20,943,807	2,253,062	137,410,217	67,471,667	
1902	98,574,367	5,271,609	3,182,993	24,570,826	23,519,894	2,785,104	157,904,793	41,373,595	
1903	103,117,178	4,846,165	3,451,307	29,637,241	24,838,103	2,953,470	188,543,464	74,607,068	
1904 <sup>1</sup>	97,916,733	4,819,171	3,576,092	32,332,385	24,415,054	2,999,030	166,058,465	73,156,709	
	1,448,197,679	131,511,597	44,153,285	304,950,659	407,357,183	33,776,248	2,376,946,451	1,696,963,748	

<sup>1</sup> Preliminary figures.



## CHARACTER OF COAL AND ITS USES.

The fuel constituents of coal consist primarily of the fixed or non-volatile carbon and the volatile hydrocarbons. The other constituents may be classed as ash and water, the former consisting of non-carbonaceous matter which was deposited in the bed of vegetable débris, and therefore partakes of the character of the sedimentary deposit of the period. To this is added whatever was subsequently brought in by percolating waters. When not present in sufficiently large amounts to seriously retard combustion its influence is for the most part purely negative although it may at times contain fusible constituents that may prove of positive harm by forming clinkers on the grate bars. The percentage of ash in commercial coals varies from 1 to 15 per cent in the best coals, the amount generally varying between 2 and 8 per cent. One of the most serious constituents of the ash is sulphur which on combustion readily corrodes the surfaces of iron with which it comes in contact. The percentage of sulphur varies in most commercial coals from a fraction of 1 to 4 per cent, although it generally becomes a serious injury to the coal for most purposes when it exceeds 1 per cent. Another injurious constituent is phosphorus. Both sulphur and phosphorus are particularly harmful in coal used for metallurgical purposes.

Water is also injurious when present in large amounts, since it reduces the fuel value of coal. The amount of water varies from less than 1 per cent in anthracite to as much as 25 per cent in lignite. In most high-grade steam coals such as are found along the eastern margin of the Appalachian coal field the amount of moisture generally varies from a fraction of 1 to 3 per cent.

The relative proportion of fixed carbon and volatile combustible material varies greatly in different coals. In graphite and the graphitic anthracite all or nearly all of the volatile hydrocarbons have been driven off and the carbon present is practically all in the form of fixed carbon. In anthracite coal the fixed carbon generally varies from 80 to 88 per cent with an average of about 85 per cent, which on the basis of the percentage of fuel constituents would give about



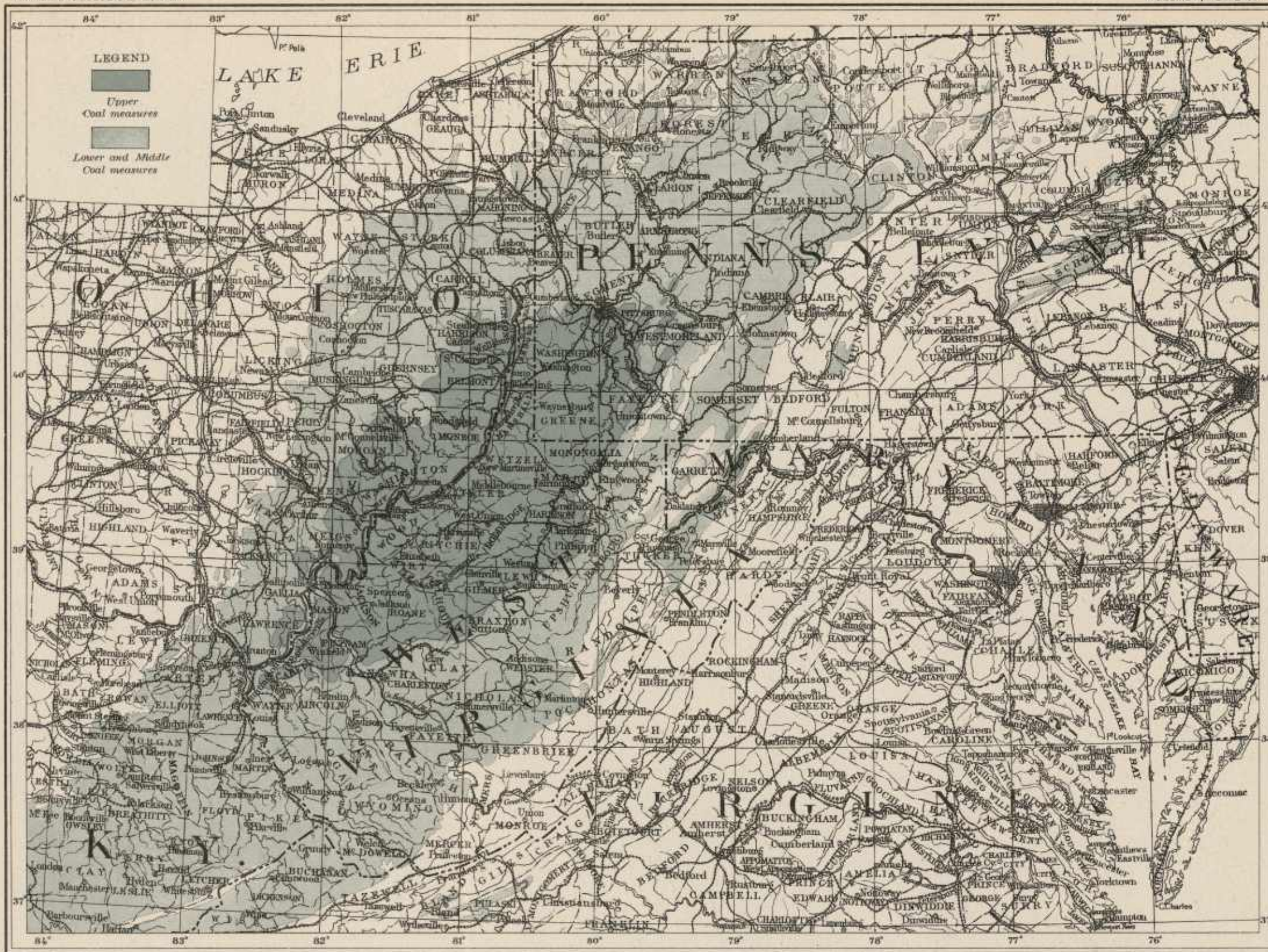

NOTE.—The Pittsburg Coal outcrops at the base of the Upper Coal Measures and is everywhere underlain by the Middle and Lower Coal Measures.

NORTHERN APPALACHIAN COAL FIELD  
AFTER U.S. GEOLOGICAL SURVEY

Scale  
0 10 20 30 40 50 100 MILES

A. J. ROSEN & CO. BALTIMORE

R. 238 B



95 per cent. The volatile matter varies commonly from 3 to 8 per cent with an average of 4 to 5 per cent, which similarly reduced would give on the basis of the percentage of fuel constituents about 5 per cent. In the case of the semi-bituminous coals the percentage of the fixed carbon varies from 65 to 80 per cent, the best coals commonly running from 70 to 76 per cent. The proportion of volatile matter varies from 14 to 26 per cent, the best coals generally showing an average of from 15 to 20 per cent. In the case of the bituminous coals the percentage of fixed carbon varies from 45 to 70 per cent and the volatile hydrocarbons from 25 to 45 per cent, the various seams in the same district differing oftentimes materially in their different parts and even the same seam may change its character in passing from one district to another.

The result obtained by dividing the percentage of fixed by the percentage of volatile carbon is known as the fuel ratio and in general the calorific or heat-producing value increases with the increase of this ratio, since the combustion of fixed carbon produces a larger amount of heat than the combustion of the volatile carbons. When the amount of volatile carbon constituents becomes so small that combustion is difficult the fuel ratio no longer expresses the real fuel value. This is the case in certain graphitic anthracites as well as of graphite itself, neither of which can be regarded as a fuel. The fuel ratios of anthracite coal range from 5 to 28, the great majority affording from 10 to 20, the average being not far from 15. Within the semi-bituminous belt along the northeastern margin of the Appalachian field the fuel ratios vary generally from 3 and 5 while throughout the remainder of the district the fuel ratios range from 1 to 3 although there are many exceptions to this general statement.

Coal is used for a great variety of purposes, among the more important coals being domestic coals, steam coals, gas coals, metallurgical coals, and smithing coals. The kind of coal used for a particular purpose depends to a considerable extent on the proximity of the fuel of a particular quality, although for special purposes the particular type of coal desired may be transported to great distances. For example, anthracite coal is coming to be more and more largely

employed exclusively for domestic purposes throughout the eastern and northern states along the seaboard and adjacent to the Great Lakes, while bituminous coal is largely used for the same purposes in other sections of the country. Again, the semi-bituminous coals are greatly prized for steam-producing purposes along the eastern seaboard while the softer bituminous coals serve the same purpose to the west of the Alleghany mountains. On the other hand, the smithing requirements are such that the better grades of semi-bituminous coals are shipped from the northeastern Appalachian field to all sections of the country for that purpose, going even to the Pacific coast. In general the bituminous coals with their high percentage of volatile hydrocarbon are best adapted to gas-making. Furthermore, certain characters for the most part unrelated to the chemical composition of the coal determines its value for coking purposes. Most coking coals have a fuel ratio of between 1 and  $2\frac{1}{2}$ . Coals relatively low in ash and sulphur, however, are best adapted for coke-making.

There are several varieties of coal in the Appalachian bituminous field in addition to those which are designated as semi-bituminous and bituminous coals. Among the bituminous coals are special kinds known as splint, cannel, and block coals whose characters are dependent on textural features, in part produced by the conditions under which they were originally deposited and in part by the structural changes which have since taken place in the beds themselves. The block coals, for example, show a tendency to break up into more or less cubical blocks. The cannel coals are very homogeneous in texture, contain a large amount of volatile matter, and are described by Newberry as having been formed in lagoons by the accumulation of fine carbonaceous mud which had its origin in completely macerated vegetable tissue. An interesting feature in the constitution of some coal beds is that one variety of coal may exist above, another below a parting within the same seam, or on the other hand, a special variety of coal may appear in one part of the seam in one district while another variety may be present at the same horizon in an adjacent region.

# GEOLOGY OF THE MARYLAND COAL DISTRICT

BY  
GEO. C. MARTIN

---

## STRATIGRAPHY OF THE MARYLAND COAL MEASURES.

### INTRODUCTORY.

The rocks which form the surface of the Maryland coal district are entirely of the class known as *sedimentary* or *clastic*—that is, they represent deposits of material derived from the destruction of older rocks and laid down by moving water. The details of this process will be described more fully in the chapter dealing with the geological history of the region.

These rocks, like all rocks of sedimentary origin, are *stratified*—that is, they consist of distinct, superimposed beds which differ from each other in composition, texture, and appearance. Some consist of pebbles cemented together, and are known as *conglomerate*; some consist of small grains of quartz sand and are known as *sandstone*; some consist of clay with more or less fine sand, and are known as *shale*<sup>1</sup> or *sandy shale* or *fire-clay*; some consist of lime with varying amounts of the shells of former animals and clay, and are known as

<sup>1</sup>The rock known as *slate* in this region is not a true slate but a *shale*. A true slate differs from a shale in mineralogical composition and in texture; it usually has a more glossy surface, is harder, splits into large thin sheets suitable for roofing, and does not break into small irregular fragments or grind up into a fine mud or clay suitable for brick making as shale does. True slate never occurs with *bituminous* coal as shale does, but is found in association with *anthracite* coal and with granite, marble, and other rocks which are foreign to this region.

*limestone*; some consist principally of carbonaceous matter of vegetable origin, and are known as *coal*. All of the above mentioned rocks are firmly consolidated and retain their form and individuality against considerable force. Rocks of another class have the same composition as these but differ from them in being unconsolidated and hence are known by other names. An unconsolidated conglomerate is a *gravel*; an unconsolidated sandstone is a *sand*; an unconsolidated shale is a *loam* or *clay*; an unconsolidated limestone is a *lime-sand* or a *marl*; an unconsolidated coal is a *peat* or *lignite*. This latter class of rocks is not abundant or prominent in this region, but some representatives are found here, and all are very abundant and important in other regions.

These various types of rock sometimes grade into each other irregularly, but generally they are separated from each other sufficiently to allow of their recognition and of the representation of their areas upon a map. This has been done upon the maps of this region published with the reports of the Survey on Allegany and Garrett counties. A stratum of rock or a series of strata which differs enough from those adjoining it in composition, appearance, or age, to permit a discussion of its distribution or its representation upon a map is called a *formation*, and each formation is named after some locality where it is typically developed and where it was first studied and described.

The coal beds of Maryland are contained in five formations. All formations are grouped according to their age into larger divisions known as *Systems*. Two of these systems are represented among the coal-bearing rocks of the region, and the representatives of several others lie deeply buried below the surface formations. The whole sequence of strata lie not in horizontal position, but folded in a series of alternating basins ("synclines") and arches ("anticlines"). These folds have been cut into by the action of streams and weather, so that in various parts of the region different strata are exposed at the surface. The character of this folding will be described into the chapter on Structure.

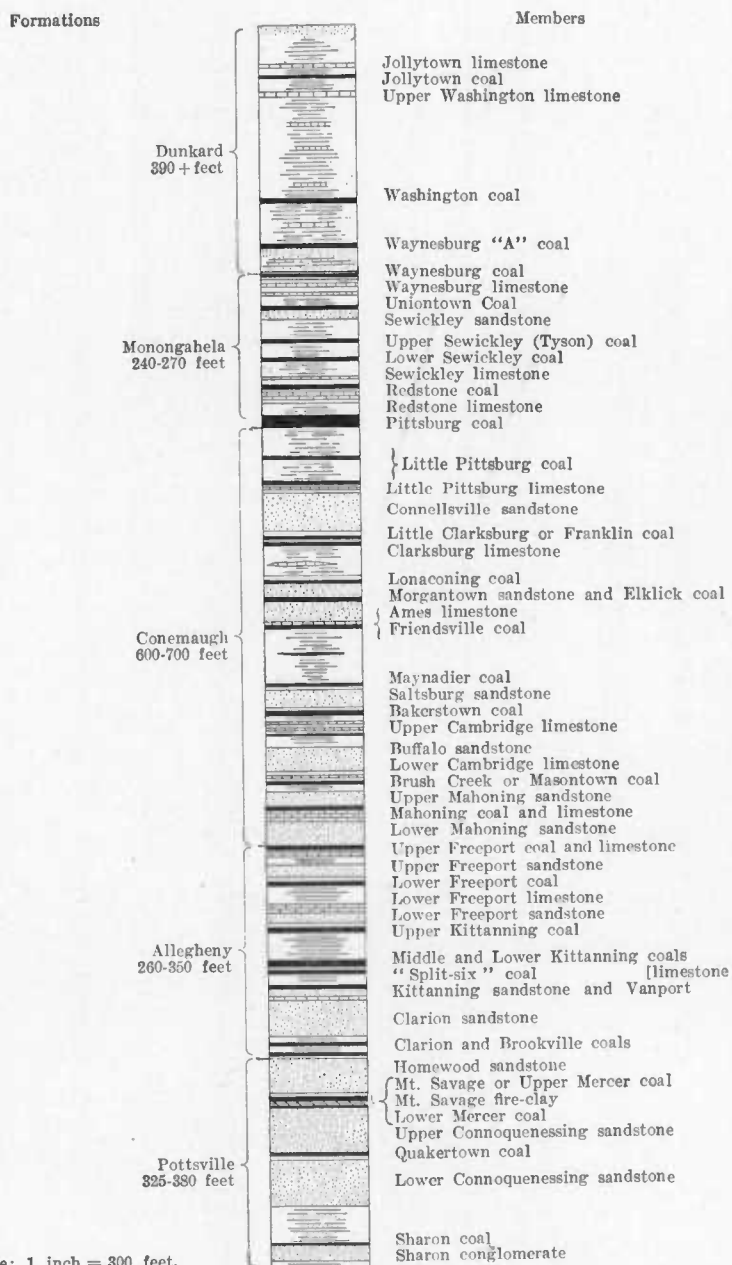

FIG. 19.—Section showing relative positions of prominent beds in Maryland Coal Measures.

The rocks which include the Maryland coal beds have been classified as follows:

## TABLE OF COAL-BEARING FORMATIONS.

## Paleozoic

Permian (?)		Dunkard
Upper Carboniferous	{ Pennsylvanian or Coal Measures	{ Monongahela Conemaugh Allegheny Pottsville

Each of these formations contains well characterized beds which have received local names. These are mentioned in their place under the discussion of each formation. The better known beds are given in their relative positions in the accompanying illustration.

## THE POTTSVILLE FORMATION.

The general character of the formation is well shown in the following sections, which show the character and the full thickness of the formation. It consists of conglomerates, sandstones, shales, fire-clays, and coals which aggregate from 325 to 380 feet in thickness and a comparison of the different sections, combined with a study of their geographical distribution, shows an increase in thickness of the formation from northwest to southeast. The formation, as found in Maryland, is marked by the development of four sandstone members, one near the base, two in the center, and one at the top, between which are varying thicknesses of shale and fire-clay and usually four rather insignificant coal seams. The Sharon coal when present lies above the lowest sandstone, the Quakertown coal between the two central sandstones, and the Mercer coals near the base of the interval between these sandstones and the Homewood sandstone at the top. The most valuable deposits of fire-clay are usually associated with these Mercer coals.



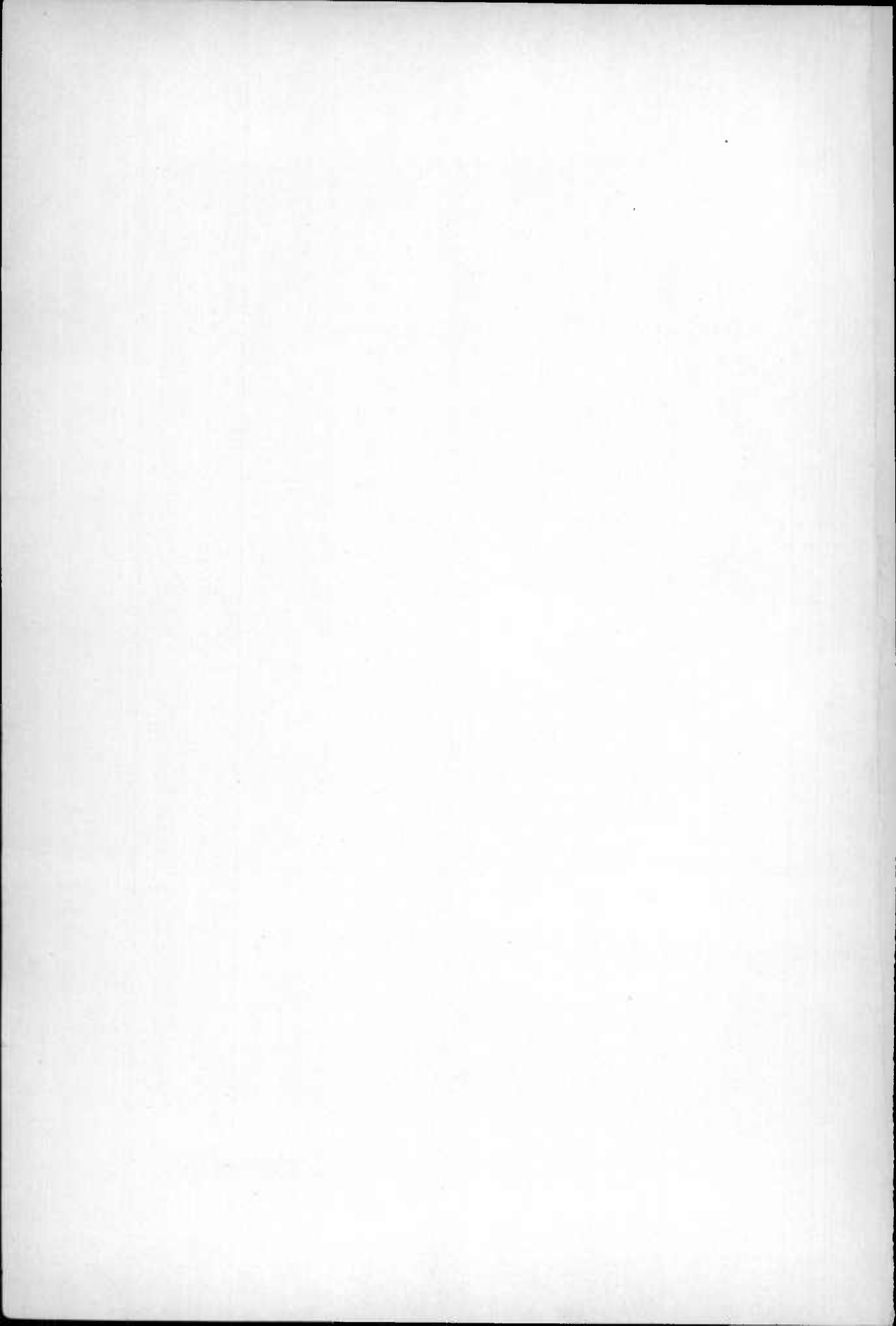

FIG. 1.—LOWER SHARON COAL AND SANDSTONE, NEAR WESTERNPORT, ALLEGANY COUNTY.

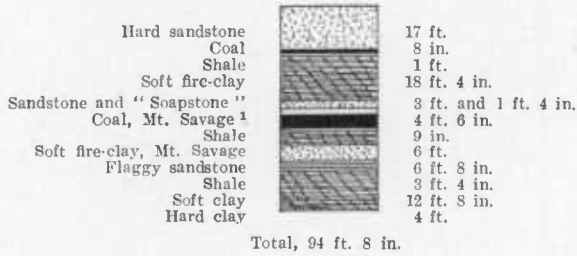

FIG. 2.—UPPER CONNOQUENESSING SANDSTONE, SWALLOW FALLS, GARRETT COUNTY.

VIEWS OF POTTSVILLE FORMATION.



PARTIAL SECTION OF POTTSVILLE FORMATION IN BIO SAVAGE FIRE-CLAY TUNNEL,  
GARRETT COUNTY.



SECTION OF THE POTTSVILLE FORMATION, ONE-HALF MILE EAST OF WESTERNPORT,  
ALLEGANY COUNTY.

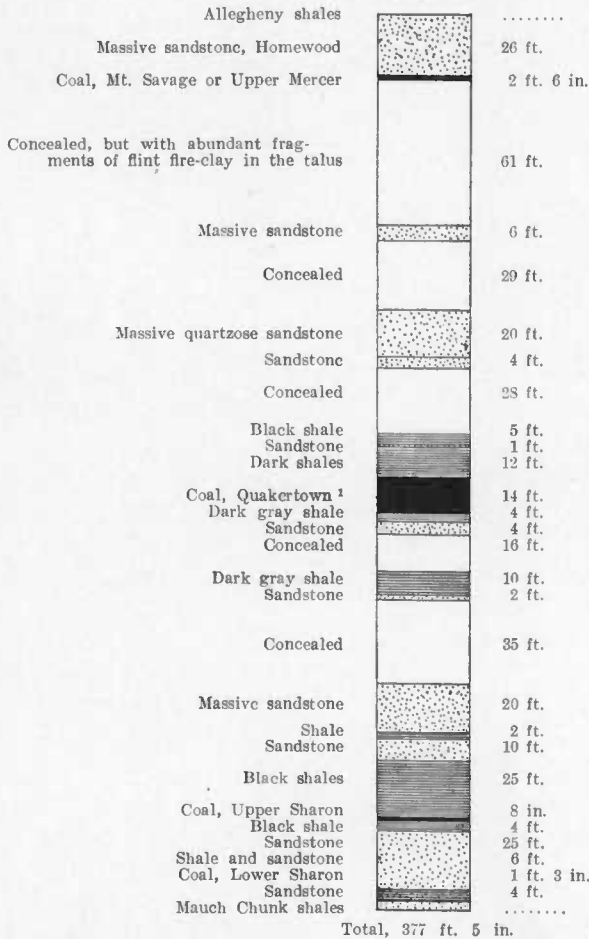

Scale: 1 inch = 75 feet.

<sup>1</sup> For details see subsequent discussion.

## PARTIAL SECTION OF POTTSVILLE FORMATION, SWALLOW FALLS, GARRETT COUNTY.

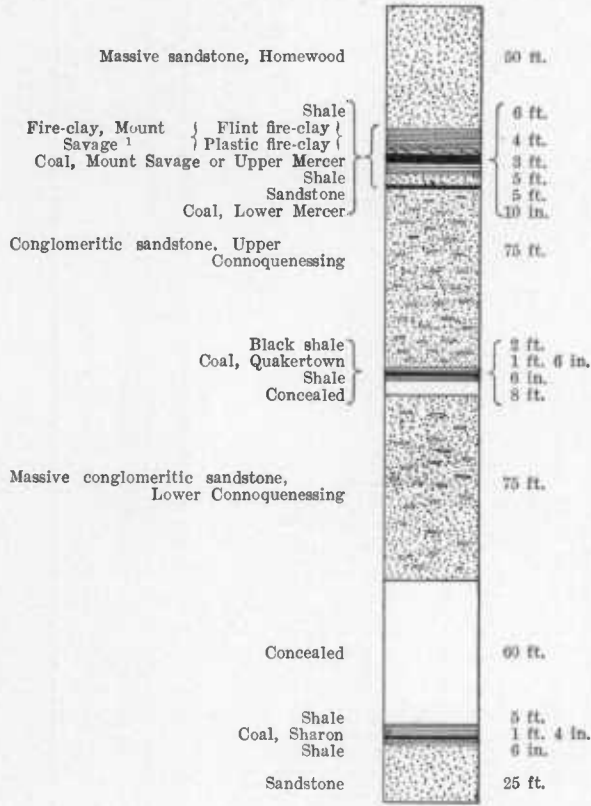

Total, 327 ft. 8 in.

## THE ALLEGHENY FORMATION.

The Allegheny formation overlies the Pottsville with apparent conformability. It consists of sandstones, shales, limestones, and coal seams aggregating in Maryland a thickness of from 260 to 350 feet. The thickness increases southeastward as was also noted in the Pottsville formation. The Allegheny formation is more shaly than the Pottsville and its sandstones are usually less prominent than those

<sup>1</sup> This is not the normal position for the "Mount Savage" fire-clay, which is usually found beneath, not above, the Mount Savage coal.

of the underlying formation. It may be thought of as extending from a few feet below the heavy Clarion sandstone near its base to the base of the equally prominent Mahoning sandstone which marks the

PARTIAL SECTION OF POTTSVILLE FORMATION FROM A BORE-HOLE AT HENRY, GARRETT COUNTY.

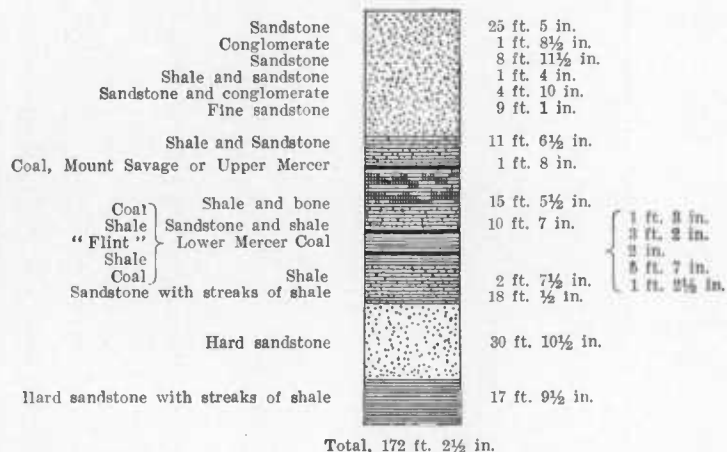

PARTIAL SECTION OF POTTSVILLE FORMATION ONE MILE ABOVE BLAINE, GARRETT COUNTY.

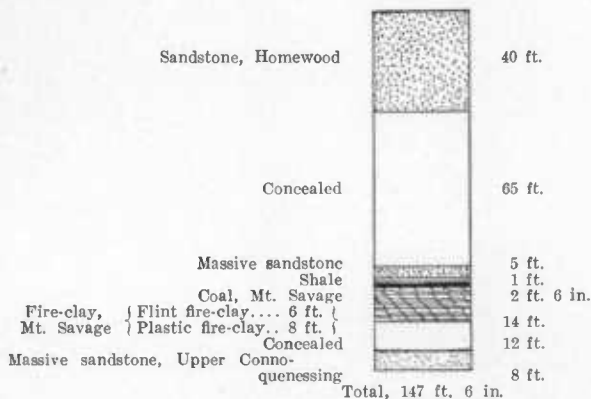

beginning of the next overlying formation. Between the Clarion and the Homewood sandstones are shales and the Brookville and Clarion coal seams. About 50 feet above the sandstone is the per-

sistent Kittanning or Davis coal seam with the impure "Split-six" below and the less valuable Upper Kittanning seam above. Below the Mahoning sandstone of the overlying Conemaugh formation are the Freeport coals. The following sections show the general character of the formation:

SECTION OF ALLEGHENY FORMATION. BORE-HOLE No. 1, HENRY, GARRETT COUNTY.

Mahoning sandstone, etc.	.....	5 ft. 2 in.
Coal, Upper Freeport		2 ft. 2½ in., 11½ in., and 7 ft. 6½ in.
Shale, limestone and shale		10 ft. 3 in.
Sandstone with streaks of shale		
Sandstone		13 ft. 3 in.
Conglomerate and Conglomeritic sandstone]		1 ft. 7½ in. and 5 ft. 6 in.
Light gray sandy shale		13 ft. 3 in.
Sandstone		17 ft. 5 in.
Shale		2 ft.
Shaly sandstone		21 ft. 3 in.
Shale		15 ft. 1 in.
Shaly sandstone		24 ft. 10 in.
Bone and shale		2 in. and 3 ft.
Sandstone and shale		1 ft. 10 in. and 1 ft. 1 in.
Limestone		1 ft.
Shale		16 ft. 3 in.
Black shale with streaks of bone		1 ft. 1 in.
Shale		11 ft. 0½ in.
Sandstone and shale		14 ft. 5¼ in.
Black shale, sandy shale, and sandstone		3 ft. 1½ in., 3 ft. 8 in., and 2 ft. ¾ in.
Black shale		2 ft. 4 in.
Coal, Middle and Lower Kittanning		8 ft. 5½ in.
Shale		19 ft. 2½ in.
Rough coal and shale ("Split-six")		2 ft. 1½ in.
Sandstone and black shale		4 ft. 4 in. and 4 ft. 5 in.
Shale, bone, and shale		7½ in. and 6 ft. 5 in.
Limestone, Vanport		2 ft. 8 in.
Shale		12 ft. 8½ in.
Hard finity sandstone		13 ft.
Conglomerate		7 ft. 4½ in.
Sandstone		5 ft. 11 in.
Shale and sandstone		22 ft. 11½ in.
Sandstone		8 ft. 4½ in.
Shale		1 ft. 2 in.
Coal, Clarion		1 ft. 6½ in.
Shale		10 ft. 2 in.
Coal, Brookville		3 ft. 5½ in.
Shale		4 ft. 7½ in.
Homewood sandstone, etc.	.....	
Total, 341 ft. 8½ in.		

Another bore-hole (No. 5) about three miles from this gave the following section of the upper part of the Allegheny formation:

PARTIAL SECTION OF ALLEGHENY FORMATION, BORE-HOLE No. 5, ONE AND ONE-HALF MILES N. W. OF BAYARD, GARRETT COUNTY.

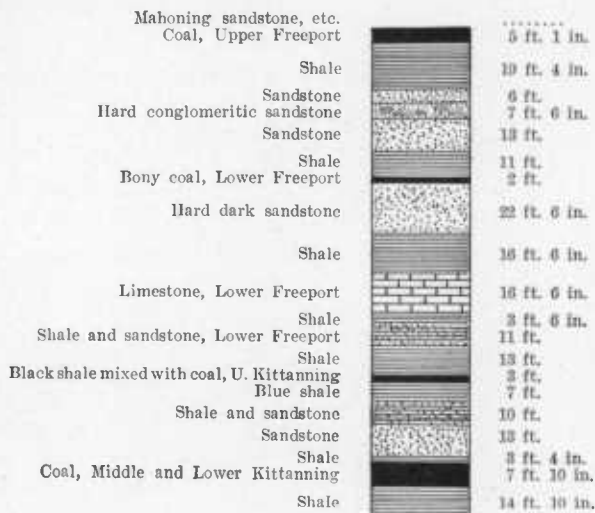

Total, 200 ft. 8 in.

On the east side of the Potomac at Harrison is the following section: SECTION OF ALLEGHENY FORMATION AT HARRISON, W. VA.

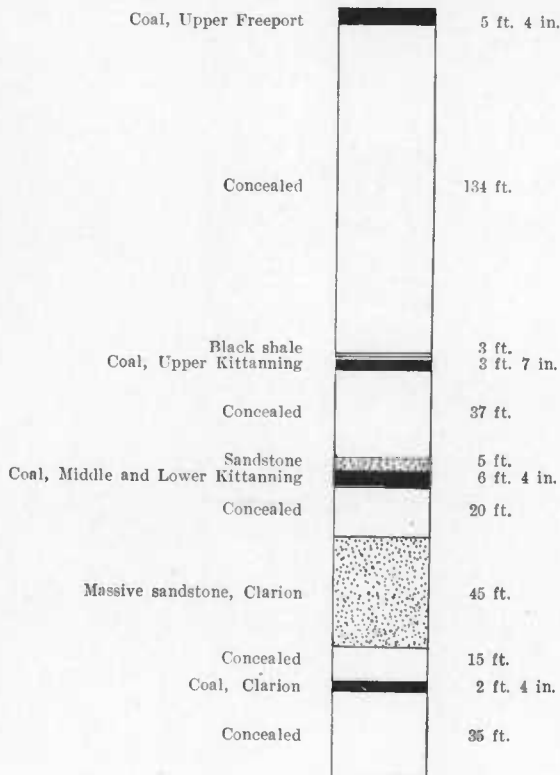

Total, 311 ft. 7 in.

SECTION OF ALLEGHENY FORMATION IN BORE-HOLE AT JENNINGS MILL, GARRETT COUNTY.<sup>1</sup>

Coal, Upper Freeport		13 ft. 5 in.
Shale		4 ft.
Shaly sandstone		9 ft.
Gray shale		35 ft. 5 in.
Brecciated fire-clay		8 in.
Gray shale		12 ft.
Coal		2 in.
Gray shale and black shale		11 ft. 7 in. and 9 in.
Coal, Lower Freeport		1 ft. 2 in.
Black shale		1 ft.
Gray shale		18 ft. 9 in.
Sandy shale		15 ft.
Coarse sandstone		12 ft.
Gray shale		1 ft.
Coarse sandstone		3 ft.
Black shale		8 ft. 10 in.
Coal, Middle and Lower Kittanning		14 ft. 1 in.
Gray shale		8 ft. 6 in.
Coarse sandstone		10 ft.
Coarse crossbedded sandstone		20 ft.
Coarse sandstone		11 ft.
Shaly sandstone		10 ft.
Gray shale		6 ft. 6 in.
Sandy shale		7 ft.
Dark gray and black shale		7 ft.
Coal, Clarion		8 in.
Gray shale and gray sandy shale		4 ft. and 5 ft.
Black shale		5 ft.
Coal, Brookville (?)		1 ft.
Total, 257 ft. 6 in.		

SECTION OF ALLEGHENY FORMATION IN BIG SAVAGE FIRE-CLAY TUNNEL, GARRETT COUNTY. ....

Coal, Upper Freeport	<table border="0"> <tr> <td>Sandstone, Mahoning</td> <td>.....</td> </tr> <tr> <td>Coal... 1 ft. 1 in.</td> <td></td> </tr> <tr> <td>Shale... 1 ft. 6 in.</td> <td></td> </tr> <tr> <td>Coal... 1 ft. 7 in.</td> <td></td> </tr> <tr> <td>Shale... 1 in.</td> <td></td> </tr> <tr> <td>Coal... 1 ft. 1 in.</td> <td></td> </tr> </table>	Sandstone, Mahoning	.....	Coal... 1 ft. 1 in.		Shale... 1 ft. 6 in.		Coal... 1 ft. 7 in.		Shale... 1 in.		Coal... 1 ft. 1 in.			6 ft. 2 in.
Sandstone, Mahoning	.....														
Coal... 1 ft. 1 in.															
Shale... 1 ft. 6 in.															
Coal... 1 ft. 7 in.															
Shale... 1 in.															
Coal... 1 ft. 1 in.															
	Soft shale		27 ft.												
	Sandstone		2 ft. 4 in.												
	Shale		8 ft.												
	Sandstone		1 ft.												
	Shale		9 ft. 10 in.												
	Sandstone and black shale		1 ft. 6 in. and 2 ft. 4 in.												
	Coal, Lower Freeport		2 ft. 3 in.												
	Soft shale		20 ft. 10 in.												
	Coal		6 in.												
Hard, sandy shale, shale, and sandstone			2 ft. 5 in., 5 in., and 1 ft. 6 in.												
Coal, Upper Kittanning?			2 ft. 6 in.												
	Bony shale		8 in.												
	Shale		6 ft. 4 in.												
	Hard sandstone		40 ft. 8 in.												
	Hard shale		3 in.												
	Sandstone		2 ft. 2 in.												
Shale, hard, black shale, and shale			5 ft. 2 in., 5 ft. 4 in., and 1 ft. 8 in.												
	Hard, impure fire-clay		6 ft. 4 in.												
	Soft fire-clay		1 ft.												
	Sandstone, shale, and sandstone		2 ft. 8 in., 3 ft. 6 in., and 4 ft. 6 in.												
Shale, soft fire-clay, and sandstone			8 in., 6 in., and 6 ft. 8 in.												
	Shale		8 ft. 10 in.												
	Black shale		8 in.												
Soft fire-clay, brown and shaly			25 ft.												
	Coal		6 in.												
	Shale		2 ft. 6 in.												
Total, 205 ft. 10 in.															

<sup>1</sup>This section extends from a depth of 193 feet to 451 feet. The record of the overlying beds is given on p. 253.



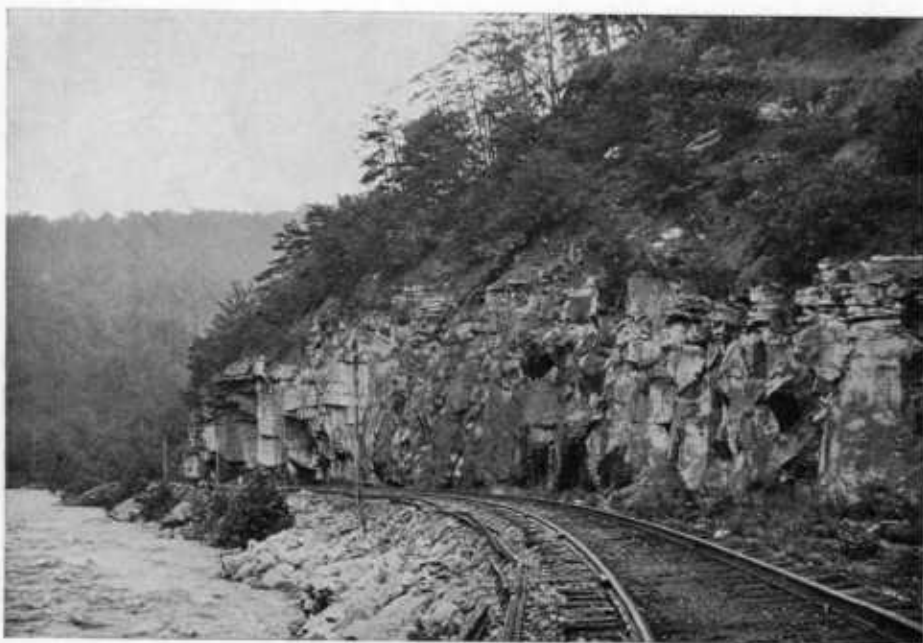

FIG. 1.—CLARION SANDSTONE, NEAR WINDOM, GARRETT COUNTY.

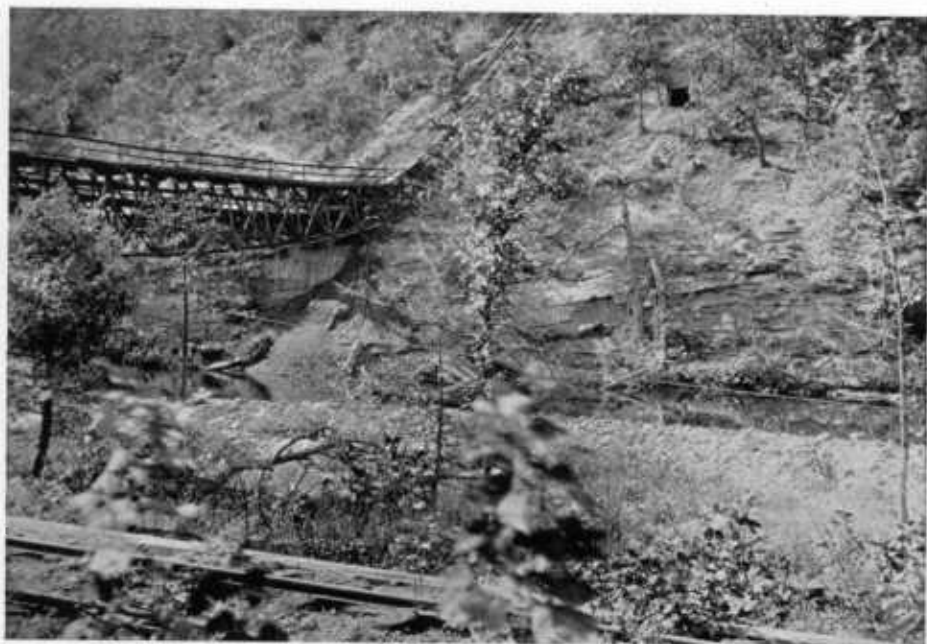
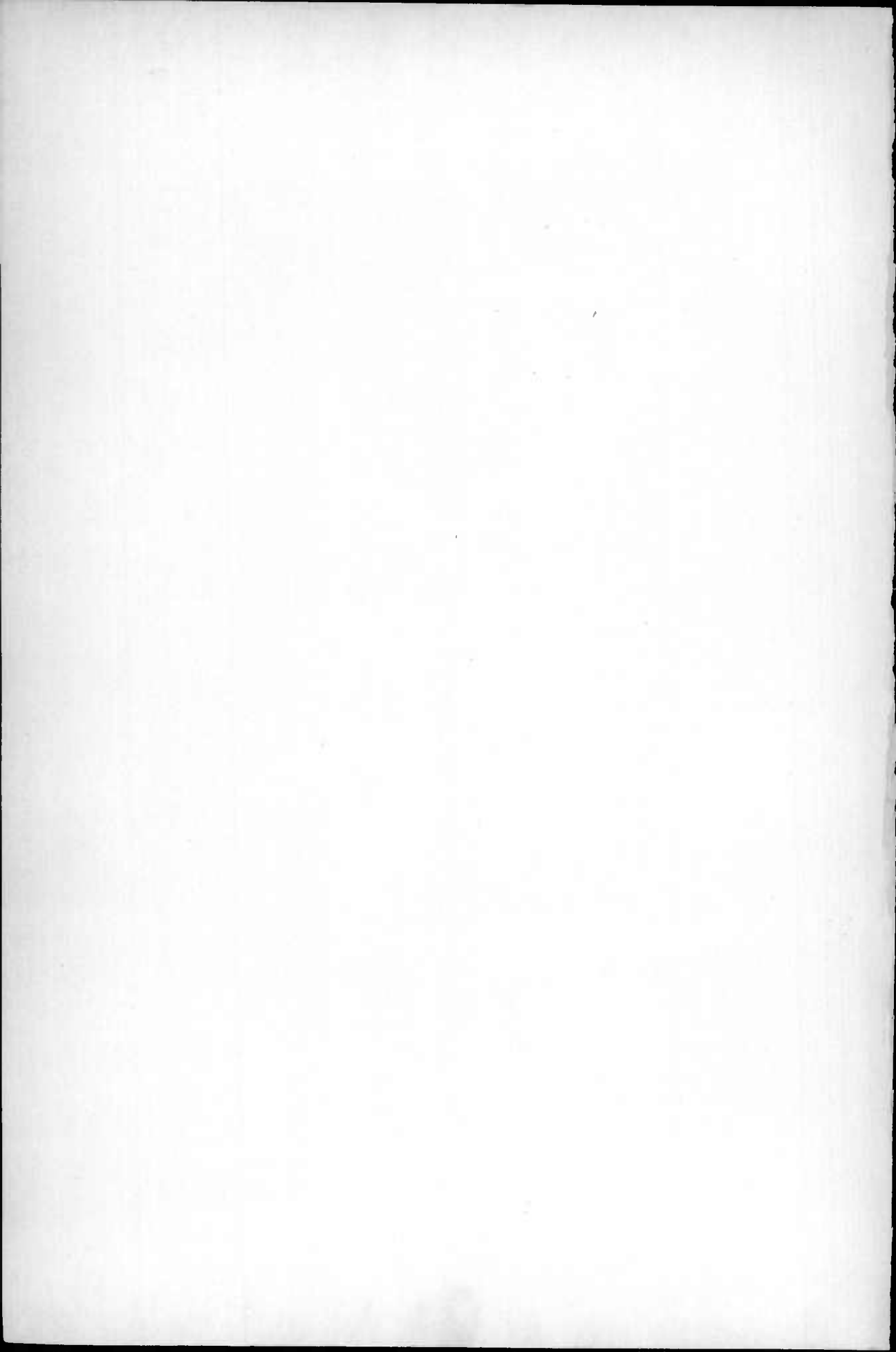

FIG. 2.—LOWER KITTANNING COAL AND SANDSTONE, NEAR BARNUM, W. VA.

VIEWS OF ALLEGHENY FORMATION.



THE CONEMAUGH FORMATION.

The Conemaugh formation consists of about 600 feet of sandstone, shale, conglomerate, limestone, fire-clay, and coal of considerable regularity of occurrence. It is usually possible to recognize five sandstones in the Conemaugh formation; the Mahoning sandstone,

SECTION OF CONEMAUGH FORMATION AT BARTON, ALLEGANY COUNTY.<sup>1</sup>

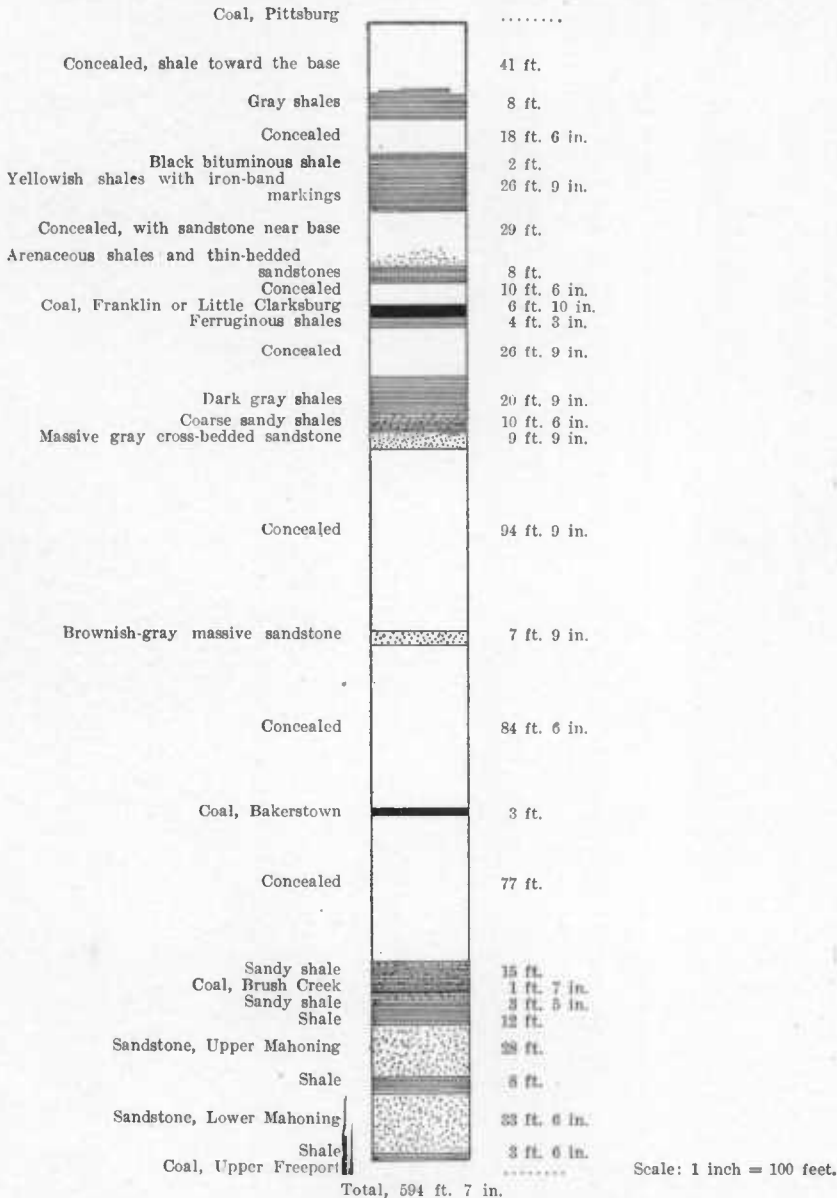

<sup>1</sup>This section from the Pittsburgh to the Bakerstown was measured at Swanton plane, while the remainder was obtained from the American Coal Co's bore-hole at Barton.

which is often divided into two members by the presence of limestone or coal, lies at the base; the Buffalo sandstone separated from it by intervening shales, limestone, and Brush Creek coal; the Saltsburg sandstone about a hundred feet higher up just above the Bakerstown coal; the rather conglomeritic Morgantown sandstone about the same distance above the Saltsburg sandstone; and the Connellsville sandstone some twenty-five feet above that. Between the Buffalo and Saltsburg sandstones are red and green shales with inter-bedded limestone and coals; between the Saltsburg and Morgantown sandstones are the Maynadier, Friendsville, and Ames coals, when developed, inter-bedded with shales carrying the Lonaconing and Franklin or "Dirty-nine" coals and occasionally limestone. Above the Connellsville sandstone is an interval of about 100 feet below the Pittsburg seam occupied by shales and carrying the Little Pittsburg coals. The following sections are typical of the formation:

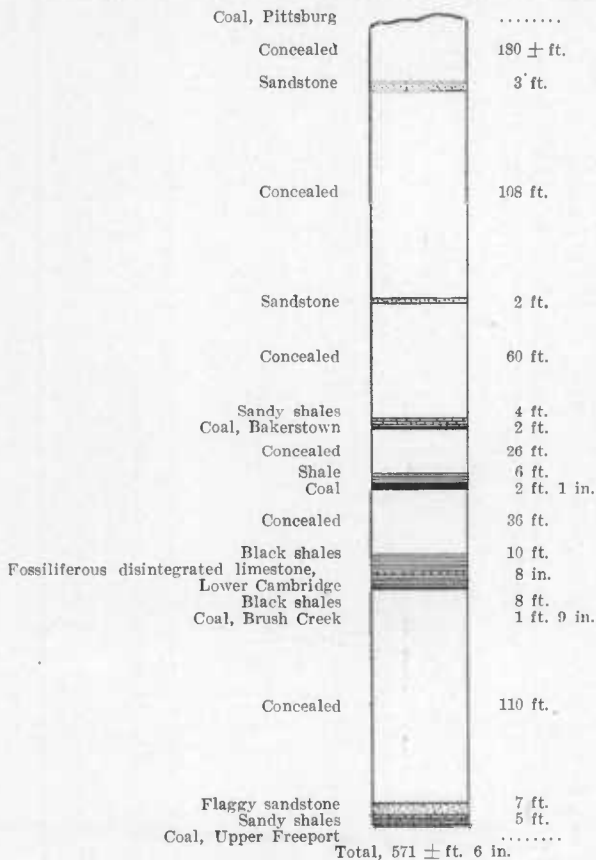
SECTION OF CONEMAUGH FORMATION NEAR BLAINE, GARRETT COUNTY.<sup>1</sup>

<sup>1</sup>The upper five measurements were made on the hillside below (W. of) Elkgarden; the remainder, one mile north of Blaine.

SECTION OF CONEMAUGH FORMATION IN CASTLEMAN VALLEY, GARRETT COUNTY.<sup>1</sup>

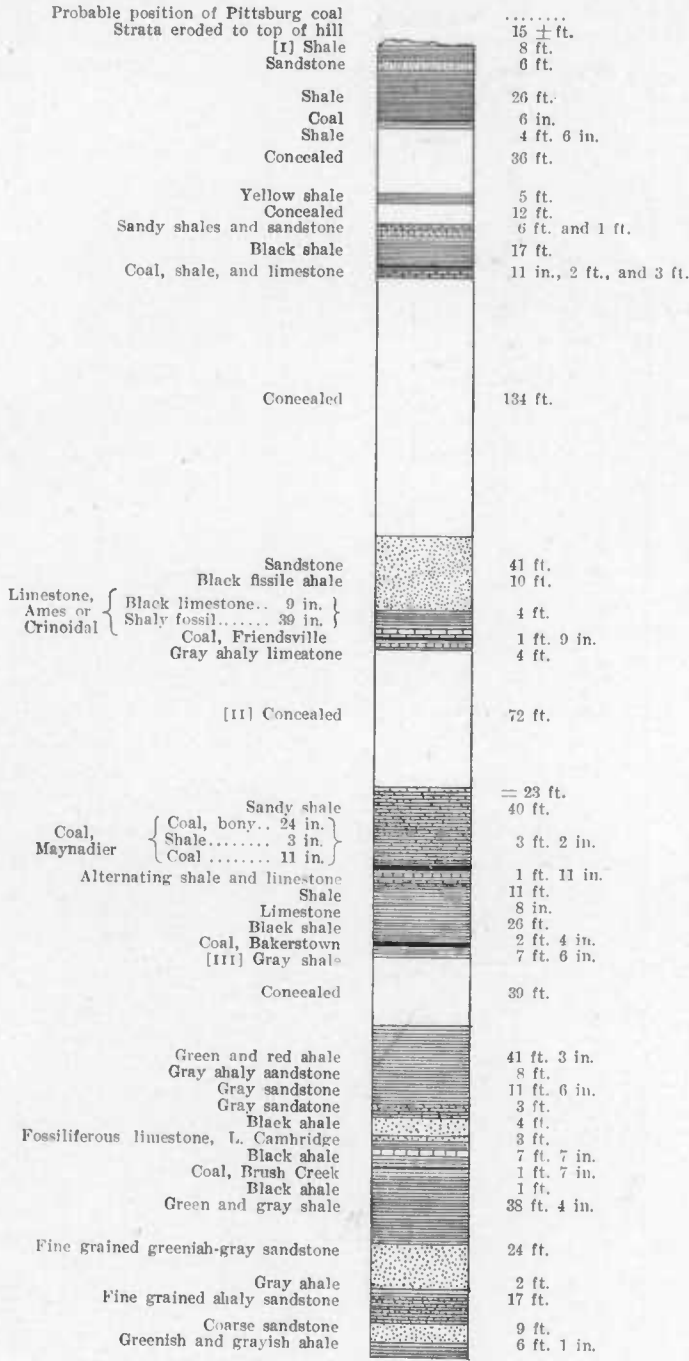

Total, 718 ft. 10 in.

<sup>1</sup> From [I] to [II], measured on north end of Ridgleys Hill; [II] to [III], in railroad cut one mile south of the National Road; the remainder from a bore-hole at Jennings Mill.

SECTION OF CONEMAUGH FORMATION, ONE-HALF MILE NORTHWEST OF FRIENDS VILLE, GARRETT COUNTY.

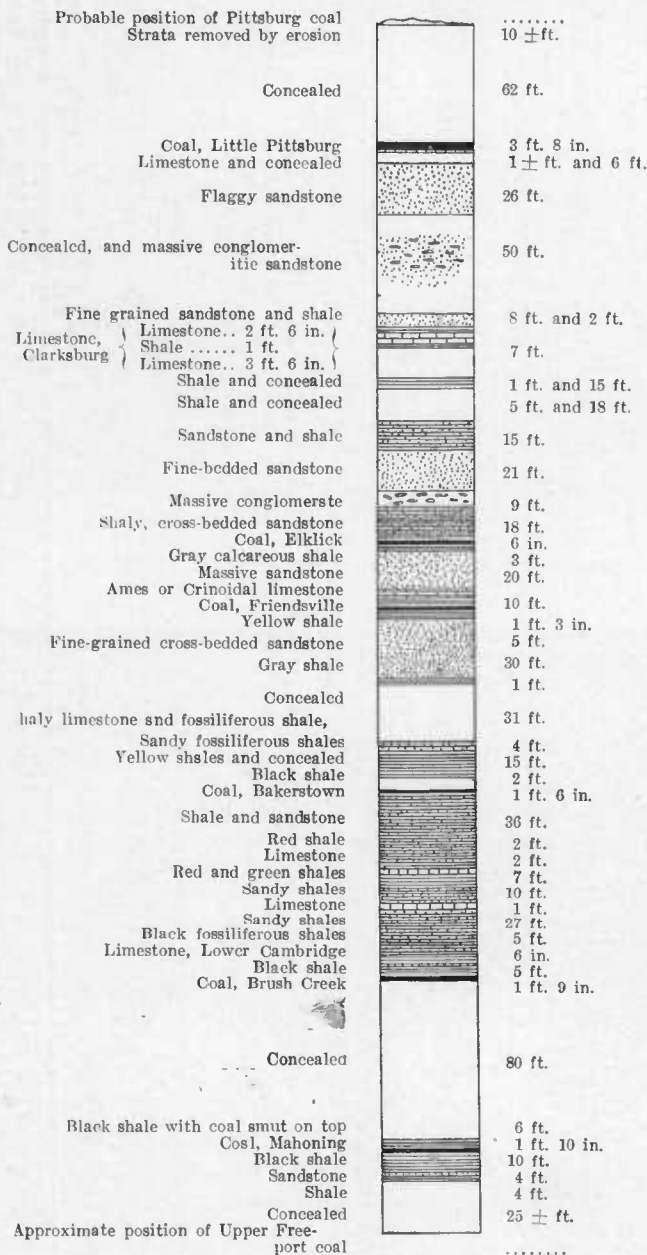

Total, 635 ft. 4 in.



FIG. 1.—FRANKLIN COAL, NEAR LONACONING, ALLEGANY COUNTY.



FIG. 2.—MORGANTOWN SANDSTONE, NEAR LONACONING, ALLEGANY COUNTY.

VIEWS OF CONEMAUGH FORMATION.





























THE MONONGAHELA FORMATION.

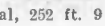











The Conemaugh formation is conformably overlain by the Monongahela formation consisting of shales, sandstones, limestones, and coal-seams aggregating from 240 to 270 feet in thickness. At the base is the valuable Pittsburg coal seam succeeded at intervals of

SECTION OF MONONGAHELA FORMATION IN PUMPING SHAFT, TWO MILES SOUTH OF FROSTBURG, ALLEGANY COUNTY.

Coal, Waynesburg or Koontz Concealed		1 ft. 10 in. 20 ft.
Limestone, Waynesburg		5 ft. 7 in.
Silicious fire-clay		3 ft. 11 in.
Sandstone and shale		10 in. and 4 ft. 10 in.
Sandstone and shale		1 ft. 8 in. and 20 ft.
Coal, Uniontown		5 in.
Shale		5 ft. 8 in.
Sandstone, Sewickley		14 ft. 2 in.
Shale		38 ft.
Coal, Upper Sewickley or Tyson		5 ft. 6 in.
Shale		16 ft.
Sandstone		4 ft.
Shale		25 ft.
Sandstone		1 ft.
Coal, Lower Sewickley		2 ft. 6 in.
Shale		18 ft.
Sandstone		10 in.
Shale		9 ft. 6 in.
Limestone, Sewickley		5 ft. 6 in.
Shale		7 ft. 8 in.
Coal and shale, Redstone		7 ft. 4 in.
Shale		18 ft. 9 in.
Sandstone		1 ft. 2 in.
Coal, Pittsburg or "Big Vein"		13 ft. 1 in.

Total, 252 ft. 9 in.

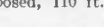
PARTIAL SECTION OF MONONGAHELA FORMATION AT BORDON SHAFT, ALLEGANY COUNTY.

Top of shaft		6 ft. 6½ in.
Hard gray sandstone		12 ft. 6 in.
Shale		3 ft. 4 in.
Coal, Tyson		8 ft. 5½ in. and 2 ft. 4 in.
Shale and sandstone		6 ft. 2 in.
Shale and sandstone		7 ft., 2 ft., and 2 ft. 9 in.
Shale, limestone, and shale		7 ft. 8 in.
Limestone and shale		8 ft. 9¼ in.
Shale		8 ft. 3 in.
Coal and shale, Redstone		1 ft. 4½ in.
Fire-clay		18 ft. 2½ in., 4 in., and 2 ft. 7 in.
Black shale, sandstone, and shale		
Pittsburg or "Big Vein" coal		12 ft. 6¼ in.

Total exposed, 110 ft. 9¼ in.

twenty to fifty feet by the Redstone, Lower and Upper Sewickley, Uniontown, and Waynesburg coal seams. There are fewer sand-

SECTION OF MONONGAHELA FORMATION AT LONA CONING, ALLEGANY COUNTY, BY P. T. TYSON, JR.

Shale above		.....
Coal		6 ft.
Limestone with shale		12 ft.
Fire-clay		13 ft. 9 in.
Concealed		3 ft. 9 in.
Shale with iron nodules		27 ft. 3 in.
Shale		27 ft. 9 in.
Fine-grained sandstone and shale		3 ft. 6 in. and 2 ft. 6 in.
Coal with two inches of shale		4 ft. 3 in.
Fire-clay		10 ft.
Coal		3 ft. 6 in.
Fire-clay		3 ft.
Coarse shaly, micaceous sandstone		51 ft.
Shale		42 ft. 6 in.
Coal and shale		13 ft. 1 in.
Shale and shaly sandstone		1 ft. 3 in. and 1 ft.
Ferruginous shale		4 ft. 8 in.
Pittsburg or "Big Vein" coal		14 ft.

Total thickness of Monongahela at Lonaconing, 238 ft. 9 in.

SECTION OF MONONGAHELA FORMATION AT KOONTZ, ALLEGANY COUNTY.

Coal, Waynesburg or Koontz		8 ft. 3 in.
Concealed		106 ft.
Coal, Upper Sewickley or Tyson		3 ft. 6 in.
Concealed		107 ft.
Shale		2 ft. 2 in.
Coal, Pittsburg or "Big Vein"		13 ft. 1 in.

Total, 240 ft.



FIG. 1.—KNOB WITH BENCH AT PITTSBURG SEAM HORIZON, 1 MILE SOUTH OF BARNUM, W. VA.

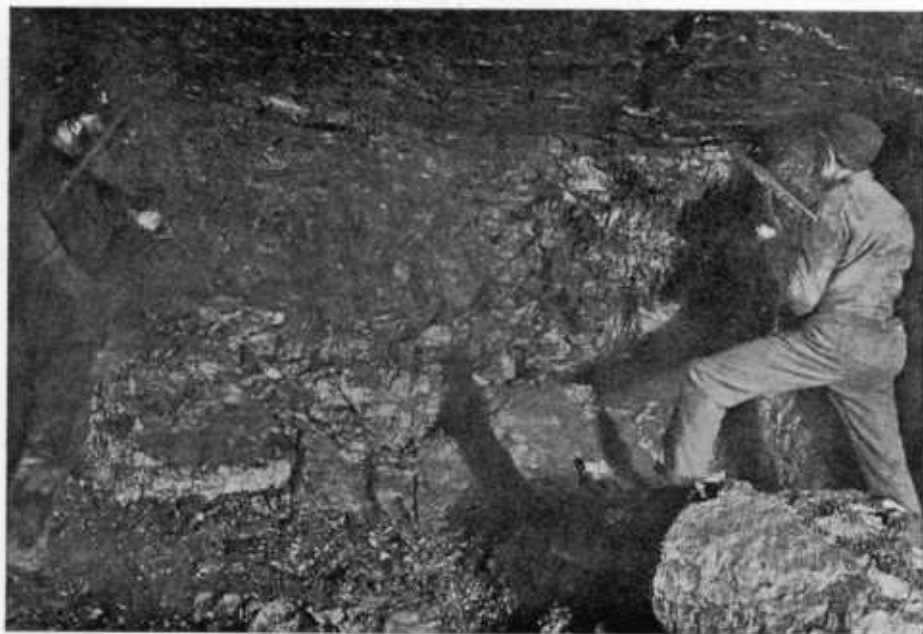
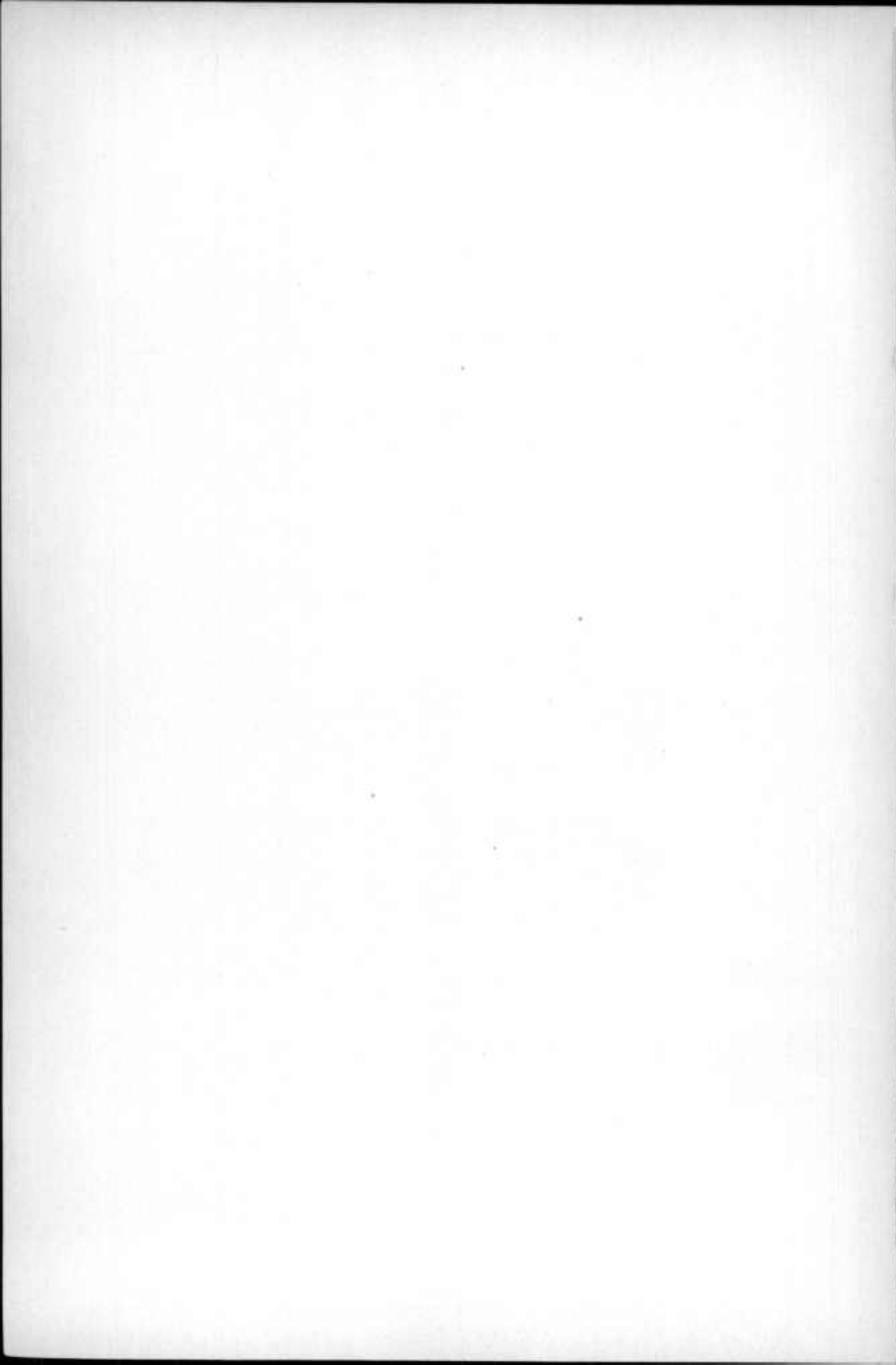

FIG. 2.—VIEW OF "BIG VEIN" COAL, OCEAN MINE NO. 3.

VIEWS OF MONONGAHELA FORMATION.



stones and these are thinner than in the previous formations and accordingly give no marked topographic guides to the stratigraphy.

SECTION OF MONONGAHELA FORMATION NEAR JACKSON MINE AT LONACONING, ALLEGANY COUNTY.

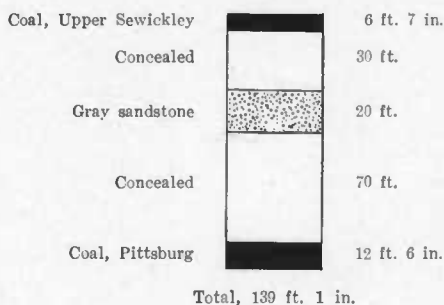

PARTIAL SECTION OF MONONGAHELA FORMATION ABOVE KINGSLAND MINE NEAR LONACONING, ALLEGANY COUNTY.

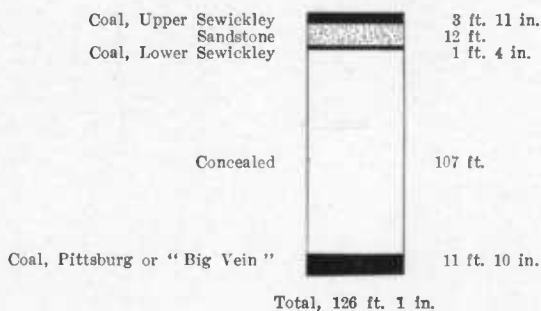

PARTIAL SECTION TWO AND ONE-HALF MILES NORTHEAST OF GRANTSVILLE. (ONE-EIGHTH MILE NORTH OF THE PENNSYLVANIA LINE.)

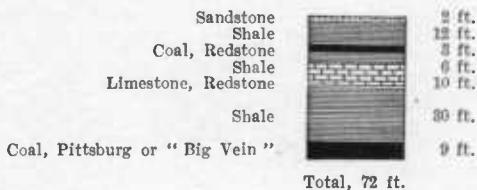

## THE DUNKARD FORMATION.

The Dunkard formation consists, in Maryland, of about 400 feet of strata best represented in the following section:

## SECTION OF DUNKARD FORMATION ON HILL EAST OF PUMPING SHAFT, ALLEGANY COUNTY.

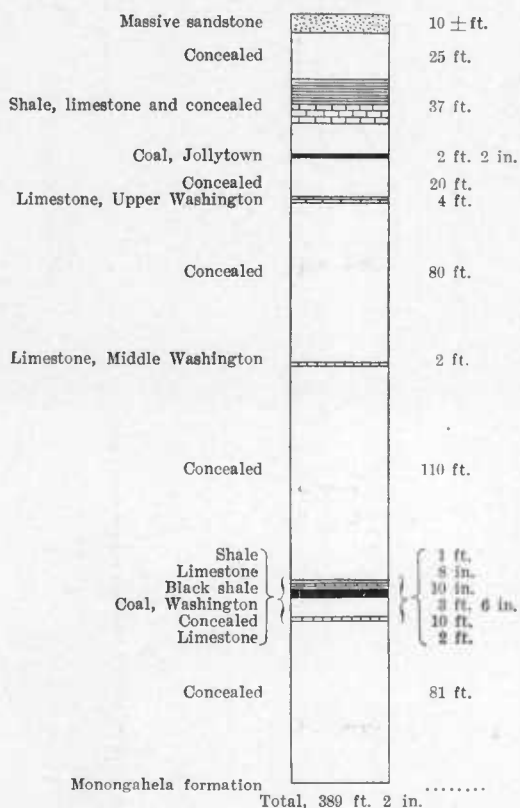

The lower beds of the Dunkard formation are well shown in the following section:

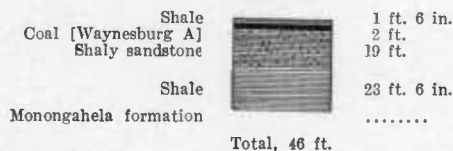
SECTION OF DUNKARD FORMATION ON "DUG HILL," NEAR LONACONINO,<sup>1</sup> ALLEGANY COUNTY.

<sup>1</sup> P. T. Tyson, Proc. Amer. Philos. Soc., vol. xi, 1871, p. 9.

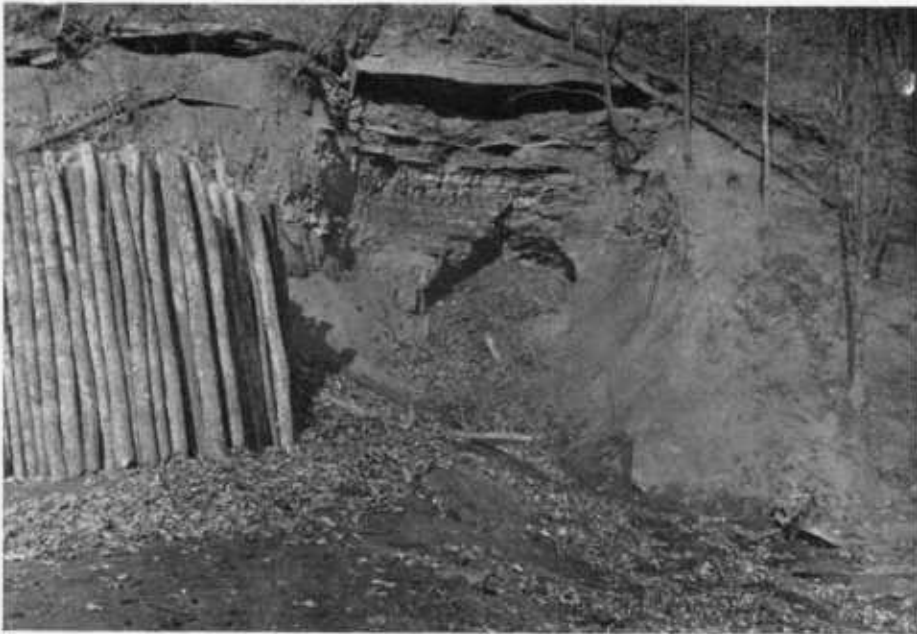
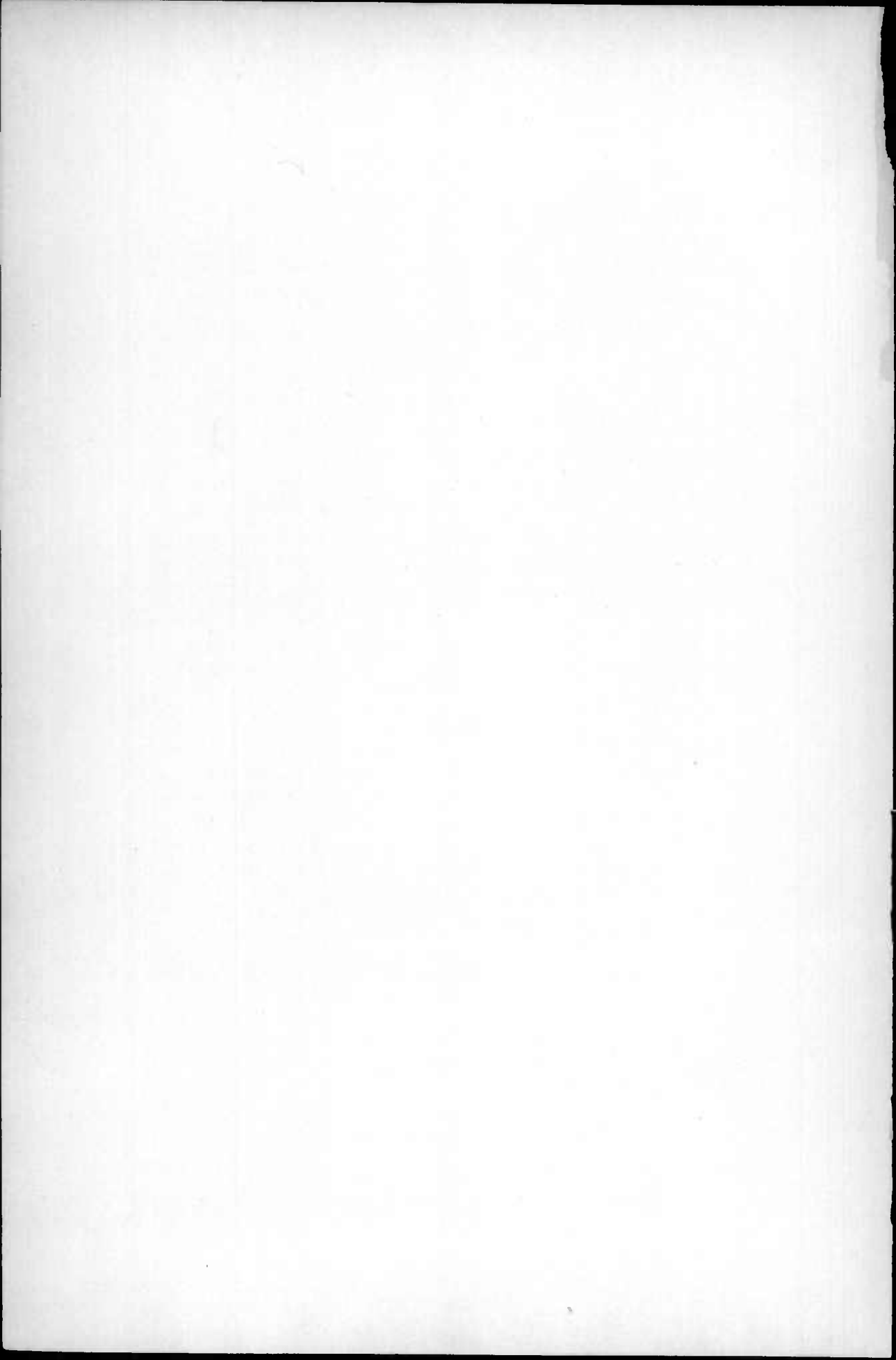

FIG. 1.—OUTCROP OF PITTSBURG SEAM, NEAR LONACONING, ALLEGANY COUNTY.



FIG. 2.—DUNKARD SLOPE, NEAR FROSTBURG, ALLEGANY COUNTY.

VIEWS OF MONONGAHELA AND DUNKARD FORMATIONS.





## GEOLOGICAL STRUCTURE OF THE MARYLAND COAL MEASURES.

The rocks of the Maryland coal district are entirely sedimentary and have been but little altered since they were deposited. Like most sedimentary rocks they were originally deposited in an almost horizontal position, but have been subsequently thrown into a series of folds.<sup>1</sup>

The Maryland coal fields lie entirely within what has been designated by Willis as the *District of Open Folding* of the *Appalachian Province*.<sup>2</sup> In this district the folds are broad and the dips relatively gentle, so that further folding would have been possible without squeezing the strata. This district has been further divided into the *Valley region* where the folds are sharp and very long and where the distinctive topographic features are "governed by structures seen in the sharp upward folds or anticlines of the narrow-crested ridges and in the wide undulating downward folds of the valleys;"<sup>3</sup> and the *Plateau region* which "is characterized by low folds of wide amplitude. In this province the structures and topographic types do not conform as they do in the valley region. Valleys follow both upon

<sup>1</sup> The elevations of the folds are known as *anticlines*, and the depressions as *synclines*. The angle which any bed makes with a horizontal plane is called its *dip*, and the direction at right angles thereto along the bed is its *strike*. If a fold has equal dips on the opposite sides it is a *symmetrical fold*, while if the dips on the opposite sides are unequal it is an *unsymmetrical fold*. The line of greatest depression of a syncline, or of greatest elevation of an anticline, from one end of the fold to the opposite is the *axis of the fold*. The angle between a line drawn along the axis on the surface of any bed, and the horizontal is the *pitch* of the axis and of the fold. An anticline which has a long horizontal or almost horizontal axis which pitches down steeply at each end is called a *cigar-shaped anticline*. A syncline which has a long horizontal or almost horizontal axis which pitches up steeply at each end is called a *canoe-shaped syncline*. An anticline which has a steep pitch downward in opposite directions from a central point is called a *dome* or *domed anticline*. and the fold is known as a *quaquaversal fold*. A syncline which has a steep pitch upwards in opposite directions from a central point may be called a *spoon-shaped syncline*.

<sup>2</sup> The Mechanics of Appalachian Structure. 13th Ann. Rep. U. S. Geol. Survey, Pt. ii, p. 224.

<sup>3</sup> Darton and Taff. U. S. Geol. Survey, Geol. Atlas, folio 28, 1896, p. 4.

the anticlinal and synclinal axes, while the mountains remain between upon the dip of the strata or limb of the fold.”<sup>1</sup> The Maryland coal district lies within and borders on the eastern edge of the “Plateau region.”

There are parts of four synclines and three anticlines in this region. Their location is shown on the accompanying map, and they are described in the following pages.

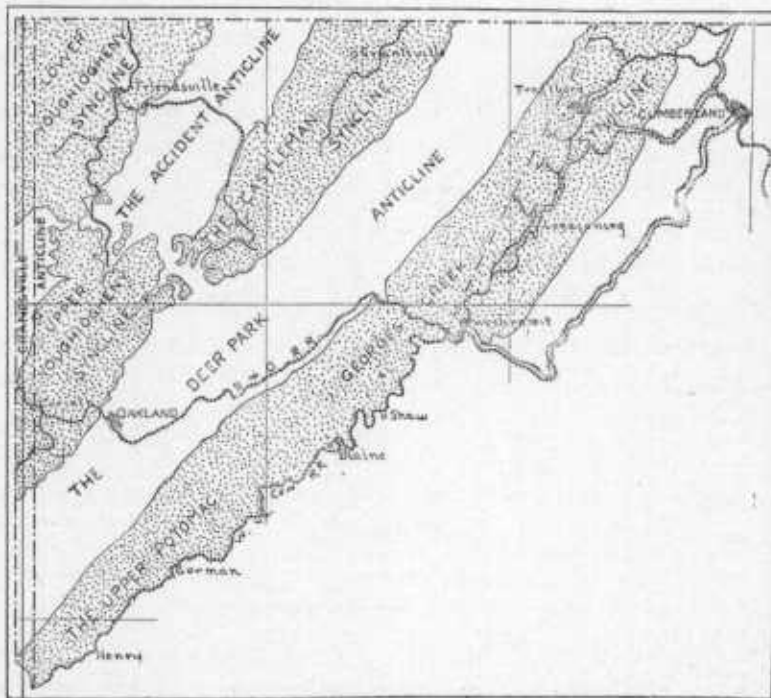

FIG. 20.—Map showing anticlines and synclines of Coal District.

#### THE GEORGES CREEK-UPPER POTOMAC SYNCLINE.

##### *Position.*

The easternmost structural feature of the Maryland coal district is a broad, rather deep synclinerium. It is named from the two

<sup>1</sup> Loc. cit., p. 5.

streams which flow along the axis. The southern part of this fold was called by Darton and Taff<sup>1</sup> the "North Potomac Syncline" while the northern part was called by O'Harra<sup>2</sup> the "Georges Creek Syncline." The further continuation of this fold into Pennsylvania has been called the "Wellersburg Syncline."

The southern part of the Maryland coal fields and the adjoining part of West Virginia have been described by Darton and Taff as follows:<sup>3</sup>

"The North Potomac synclinal fold is the first west of the valley region, and extends between the New Creek Mountain and Deer Park Valley anticlines. Rocks in the Alleghany Front dip down steeply toward the north-northwest at 18° to 60°, but they rapidly change in dip to a few degrees, and pass across the valley of the North Branch of Potomac River almost horizontally. In Backbone Mountain the same rocks rise, dipping east-southeast 15° to 25°. This wide synclinal basin of the North Potomac inclines or pitches north-northeast nearly 45.7 feet per mile. It widens southward, and divides near the center of the Piedmont quadrilateral. One prong—the Stony River syncline—is in the valleys of Stony River and Red Creek, between the Alleghany Front and Canaan Mountain. The other prong is a direct continuation of the North Potomac basin, and its axis passes almost through Fairfax Knob. This interruption and division of the North Potomac syncline is due to the Blackwater anticlinal fold. This anticline enters the area nearly in the southwest corner and extends northward approximately parallel to the Alleghany Front. The Blackwater [Pottsville] sandstone and Greenbrier formation, which once closed in an arch over the Blackwater Valley, have been removed by erosion, and the wide valley between Canaan and Brown mountains now extends along the axis of the arch. The Blackwater anticline pitches northward, down into the North Potomac syncline, and is lost near the center of the basin. Local dis-

<sup>1</sup> Darton and Taff. U. S. Geol. Survey, Geol. Atlas, folio 28, 1896, p. 4.

<sup>2</sup> Physical Features of Alleghany County, Md. Geol. Survey, 1900, pp. 150-152.

<sup>3</sup> Loc. cit., p. 5.

turbances of minor folding are indicated by dip of the rock in the Potomac Valley near Gorman and Stoyer, and in Stony River Valley above the falls on each side of the Blackwater anticline where it dies out down the pitch, but they are too small to apparently affect the general structure or to be recognized in structure sections."

It may be seen by comparison that the authors differ somewhat from Darton and Taff as to the minor details of the folding. They agree with them, however, as to the general character of the structure.

O'Harra described the Georges Creek Syncline of Allegany county as follows:—<sup>1</sup>

"The Georges Creek syncline is defined on the east by the Wills Mountain and Fort Hill antilines already described. The western limit is west of Savage Mountain beyond the borders of Allegany county, hence need not receive further mention here. The full width of this syncline, of which only the eastern and central portions lie in Allegany county, remains approximately ten miles throughout its entire course across the state. This measurement, however, is not to be confused with the width of the high valley lying between Savage Mountain and Dans-Little Allegheny Mountain which occupies scarcely more than one-half of the synclinal fold. The axis of the syncline has been designated with considerable detail by means of the various mining operations in the coal basin. Its general direction is N. 28° to 30° E. passing through Franklin, Barton, Moscow, and Lonaconing. It lies a little to the west of Westernport and passes through the immediate vicinity of Mount Savage.

"Steeply-dipping Silurian and Devonian strata occupy the eastern border of the syncline, but gradually growing less steep westward from Wills Mountain they disappear one by one beneath the high-lying Carboniferous strata of the coal basin.

"In the gap through which Jennings Run flows, where many of the strata, particularly those of the Hampshire formation, have an excellent exposure, the gradually decreasing inclination of the beds may

<sup>1</sup>Physical Features of Allegany County, Md. Geol. Survey, 1900, pp. 150-152.

be clearly seen. Numerous good exposures further south along Braddock Run and still further south in the Potomac gorge also aid materially in arriving at correct conclusions concerning the structure of this part of the county.

"At the Jennings-Hampshire contact in the Jennings Run gap the dip is  $68^{\circ}$  W. At the Hampshire-Pocono contact the dip has gradually decreased to  $28^{\circ}$  W. At the Pocono-Greenbrier contact it is  $17^{\circ}$  W., while at the Mauch Chunk-Pottsville contact the dip is only  $13^{\circ}$  W. Further west the dip continues to gradually grow less.

"In the Potomac gorge and along Braddock Run the favorable places for observation cannot be concisely described but the measurements obtained correspond closely to those made along Jennings Run.

"These measurements were all obtained near the level of the streams mentioned, hence following the various formations upward to the positions which they occupy in the higher parts of the Allegheny Front the dip is found to increase slightly. Opportunities are not good for learning definitely how much this increase is, but it is known that the Pottsville dips from  $16^{\circ}$  W. to  $22^{\circ}$  W. where best exposed along the high crest of Dans-Little Allegheny Mountain.

"Outcrops of strata in Allegany county suitable for accurate measurement of the dip are rare west of the synclinal axis. Southward from the state line the Allegany-Garrett line gradually approaches the position of the synclinal axis, hence the western limb of the syncline is but poorly represented in Allegany county. It seems, however, that the steepness increases somewhat less rapidly west of the axis and the prevailing dip of the Pottsville in the northwest corner of the county is thought to be not greater than  $12^{\circ}$  E. to  $15^{\circ}$  E. . . .

"In much of the Georges Creek syncline this [the pitch] is not quite so apparent, but in the northern part of the county the upward pitch to the north becomes perceptible, and as a result the coal measures all come to the surface within some fifteen miles north of the state line."

The western edge of this syncline may be considered as located along the line of steepest dip where the surfaces of stratification

change from an upward to a downward concavity. This line coincides approximately with the outcrop of the base of the Pottsville, with the 3200 foot contour drawn on the top of the Pottsville, and with the crest of the Great Backbone-Big Savage ridge. The northern portion of the course of the western edge of the fold is remarkably uniform, being about N. 35° E., except for about four miles in a region east of Altamont where it is about N. 50° E. The syncline is continued to the northeastward into Pennsylvania, and southwestward into West Virginia.

The axis of the fold lies entirely in Allegany county. Thence it passes into West Virginia and lies somewhat east of the Potomac river from Piedmont to Elk garden. Here, according to Darton and Taff, it divides, the eastern fork extending up the valley of Abram Creek. The western fork extends along and probably somewhat to the east of the Potomac river as far as the mouth of Stony river. Here another bifurcation takes place, one fork extending south into West Virginia, and the other crossing the Potomac river in a westerly direction to a point about two miles north of Gorman where it turns and runs southwest to the southern point of Garrett county slightly east of Fairfax Knob.

#### *Attitude of the Strata.*

The strike averages about N. 35° E. along the western edge of the fold, but toward the axis it becomes less regular. The dip varies from 20° to 45° along the edge of the fold, averaging about 30°. Toward the center of the syncline it becomes steadily smaller and less regular. Along the Potomac river it is small but quite irregular in amount and direction, being prevailingly northwestward between Fairfax Knob and the mouth of Stony river and prevailingly southeastward from this point to Bloomington.

The pitch is very slight but apparently southwestward from Fairfax Knob to a point west of Henry. From here the axis pitches northeastward at the rate of about 40 feet per mile to the valley of Shields Run. Thence it pitches southwestward at a low, irregular

angle as far as the mouth of Stony river. From here to Piedmont it pitches quite regularly to the northeastward at the rate of about 80 feet per mile. From Westernport the axis pitches to the southwest, lower and lower beds appearing successively as one passes northward toward the State line.

#### *General Features.*

The most striking features of the structure in this fold are the very uniform strike and dip along the western flank; the flattening of the center of the fold and steepening of the western flank in the valley of the Savage river; the development of a subordinate anticline with an axis extending in a northwest-southeast direction through Tasker Corners and the mouth of Stony river; and the presence of a subordinate spoon-shaped syncline west of and parallel to the Potomac above the mouth of Stony river.

The strata outcropping in this fold are those of the Mauch Chunk, Pottsville, Allegheny, Conemaugh, Monongahela, and Dunkard formations.

#### THE DEER PARK ANTICLINE.

The Deer Park anticline bounds the Georges Creek-Potomac syncline on the west throughout its entire length. Its western edge may be somewhat arbitrarily placed at the outcrop of the base of the Pottsville formation along the crest of Meadow Mountain and the geologically continuous and similar ridge which extends from the valley of Deep Creek in a southwesterly direction to the Preston county (West Virginia) line. This coincides approximately with the top of the Pottsville formation.

The rocks involved in this fold which outcrop at the surface are those of the Jennings, Hampshire, Pocono, Greenbrier, and Mauch Chunk formations. The Coal Measures are entirely absent from it.

#### THE CASTLEMAN SYNCLINE.

##### *Position.*

The Castleman syncline adjoins the north end of the Deer Park syncline on the west. It occupies the area between the crests of



Meadow and Negro mountains, the boundaries being approximately the outcrop of the base of the Pottsville formation on the crests of those mountains. The southern end of the syncline may be placed at Deep Creek which flows along a small low antiline which cuts off this syncline from the Upper Youghiogheny syncline to the southwest of it.

The axis of this fold extends from Niverton, Pennsylvania, through the eastern end of Grantsville and on to the Castleman river at a point one mile south of Grantsville. Thence it lies along the course of the Castleman as far as the forks of that stream. From here it extends to Bittinger, and then in a course of about S. 45° W. to the southern end of Meadow Mountain.

#### *Attitude of the Strata.*

The strike on the flanks of that part of the syncline southwest of Bevansville is in general parallel to the axis. Northeast of Bevansville it gradually diverges from the direction of the axis toward the east on the eastern limb of the fold and to the north on the western limb. In the region about four miles east of Accident there is a very pronounced divergence of the strike to a course almost east and west.

The dip is quite gentle and regular. It averages about 12° or 15° on the crests of Meadow and Negro mountains and decreases rapidly and quite regularly toward the axis.

The axis pitches to the northeast at a rate of about 55 feet per mile from Niverton, Pennsylvania, to a point about two and one-half miles southwest of Bittinger. From that point to the southern end of the syncline it pitches to the northeast at a rate of 200 feet per mile.

There is a fault in the sandstones and shales of the Conemaugh formation in the west bank of the Castleman river just east of Grantsville. For a distance of about 100 feet along the roadside there can be seen a massive sandstone resting horizontally upon the upturned edges of steeply dipping shales. The dip of the shales is unusual



for this region, the normal dip at this point being that of the almost horizontal sandstone. The disturbance is all the more remarkable for occurring in the center of a very open syncline where the strata are usually very slightly disturbed. The amount of displacement could not be measured but the appearance at this one locality would seem to indicate that it might be considerable. There are, however, no indications of it in any other exposures.

#### *General Features.*

This is, as far as the portion in Maryland is concerned, a typical canoe-shaped syncline. Subordinate folds and undulations of the axis are apparently lacking. It is a more simple fold than the Georges Creek-Potomac syncline or the synclines further west.

The strata involved in this fold and outcropping in it are those of the Maeh Chunk, Pottsville, Allegheny, Conemaugh, and Monongahela formations. The last do not enter Maryland but are exposed a few rods north of the Pennsylvania line.

#### THE UPPER YOUGHIOGHENY SYNCLINE.

##### *Position.*

The Upper Youghiogheny syncline adjoins the southern end of the Deer Park antiline on the west. Its western boundary is the outcrop of the base of the Pottsville formation along the crest of Snaggy Mountain. On the northeast it is separated from the Castleman syncline by the crest of the subordinate antiline referred to above. On the northwest it is separated from the Lower Youghiogheny syncline by a low antiline in the high hill south of Sang Run. On the north between the two low antilines above mentioned is the Accident antiline of which they are both prongs.

The axis of this fold enters Maryland from Preston county, West Virginia, along the line of the Preston R. R. Thence its course is N. 45° E. to the "Miehler line." From this point it extends in a somewhat sinuous course to a point about one-half mile north of Skipnish where it bifurcates. The main axis runs east for about

a mile and then turns northeast again and extends in that direction as far as the Youghiogheny river at a point about one-half mile above Oak Shoals. Here it turns north and follows roughly the course of the river as far as a point about one mile above Swallow Falls. Thence it extends in a northeasterly direction for about three miles where it is lost on the rim of the basin. The secondary axis extends from the point of bifurcation in a somewhat sinuous north-northeasterly and northerly course along the geographical center of the basin, passing through Brew Mahr Mill in the direction of Sang Run.

*Attitude of the Strata.*

The strike is very variable. Toward the edges of the basin it is parallel to the direction of the rim as described above, but in the center of the basin it is very irregular.

The dip seldom exceeds  $12^{\circ}$  or  $15^{\circ}$  on the flanks of the fold and decreases rapidly toward the axis. It is very variable in amount and direction, especially in the center of the basin.

The pitch from the point where the axis crosses the West Virginia line to the point of bifurcation is about 120 feet per mile toward the northeast. From here the main axis undulates with a pitch of from 0 to 100 feet per mile until it reaches a lowest point at a place about two-thirds of a mile southeast of Swallow Falls. For a distance of about three miles northeastward from this point the axis has a pitch to the southwest of about 200 feet per mile. Then the pitch passes into the dip of the adjacent anticline. The secondary axis has a slight pitch toward the south for a distance of about two miles north from the point of bifurcation. Then it has a slight pitch toward the north as far as a deep point under the valley of Herrington Run. From this point to the crest of the anticline in the hill south of Sang Run the pitch of the axis is southward. It gradually increases from nothing in the valley of Herrington Run to a maximum of 200 feet per mile about one mile north of Brew Mahr Mill. From this point northward it gradually decreases in amount but continues its direction southward.

*General Features.*

The most noticeable structural features in connection with this fold are the unsymmetrical character; the shortness in proportion to the width; the strong pitch compared with the relatively gentle dip; the irregular strike and dip; the bifurcating axis; and the four subordinate spoon-shaped synclines. This syncline is of a different type from those described above. It is of the class typically developed in western Pennsylvania, which characterizes the interior of the *Plateau Region* of the *Appalachian District* of *Open Folding*.

The strata outcropping in this fold are those of the Mauch Chunk, Pottsville, Allegheny, and Conemaugh formations.

## THE ACCIDENT ANTICLINE.

*Position.*

The Accident anticline adjoins the Castleman syncline on the west and the Upper Youghiogheny syncline on the north. Its western boundary is the crest of Winding Ridge. This fold forks at the southern end; one prong extending southeastward through the valley of Deep Creek, connects with Deer Park anticline, the other extending southwestward, connects with the Cranesville anticline.

The strata involved at the surface are those of the Jennings, Hampshire, Pocono, Greenbrier, and Mauch Chunk formations, none of the Coal Measures being present.

## THE CRANESVILLE ANTICLINE.

*Position.*

The Cranesville anticline adjoins the Upper Youghiogheny syncline on the west. It is bounded on the north by Feik Hill and Dog Ridge, beyond which is the Lower Youghiogheny syncline. The western and southern limits of this fold, as well as the greater part of its area, are in West Virginia.

The surface rocks involved in the part of the fold which lies east of the Brown-Bauer line are those of the Pocono, Greenbrier, Mauch

Chunk, and Pottsville formations. Along the axis in West Virginia the Jennings and Hampshire formations are exposed. The Coal Measures are absent.

#### THE LOWER YOUGHIOGHENY SYNCLINE.

##### *Position.*

The Lower Youghioghenny syncline adjoins the Accident anticline on the west, the Upper Youghioghenny syncline on the northwest, and the Cranesville anticline on the northeast. It extends northward into Pennsylvania and westward into West Virginia. It is connected with the Upper Youghioghenny syncline across the low anticline connecting the Accident and Cranesville domes.

The axis follows a somewhat sinuous course near the eastern edge of the syncline. It crosses the Pennsylvania line about one and one-half miles east of the Youghioghenny river and extends in a south-southwesterly direction. Crossing the Youghioghenny river about one mile below Selbysport, it continues on the west side of that stream and at an average distance of one-half mile from it, as far as the mouth of Trap Run. Here it takes a southerly direction, the river winding back and forth across it as far as Sang Run. From this point it extends south into the high hill south and west of the river, and joins the western fork of the axis of the Upper Youghioghenny syncline.

##### *Attitude of the Strata.*

The strike on the eastern limb of the fold is very uniformly N. 35° E. as far south as a point two miles north of Sang Run. Between here and Sang Run there is great irregularity of strike. On the western limb of the fold the strike is in general north and south, except in the southern end of the fold, where it is northwest and southeast.

The dip is very regular on the eastern limb of the fold. The maximum angle is about 20°. On the western limb of the fold the dip is very irregular in amount and in direction. It seldom exceeds 5°

or  $8^{\circ}$ . A low secondary antiline occurs in the northwest corner of Garrett county on Sickle Hill and the ridge to the northward. The dip on the western flank of this is very slight. A very strong minor fold occurs at the mouth of Laurel Run and very near the axis of the syncline. This disturbance is evidently of slight extent.

The axis descends to the northward from the southern end of the basin to the Pennsylvania line. It pitches at an average rate of about 200 feet per mile above the mouth of Salt Block Run. From the mouth of Salt Block Run to the mouth of White Rock Run the pitch is about 330 feet per mile. From this point to Krug it is about 150 feet per mile. Here it increases again and maintains an average pitch of 260 feet per mile as far as Friendsville. The pitch is very slight below Friendsville but maintains its direction to the northeastward.

#### *General Features.*

This fold differs from the Georges Creek-Potomac and Castleman synclines in being very markedly unsymmetrical. Its most striking feature is the very strong regular dip on the eastern limb as compared with the weak irregular dip of the western limb. It should be noted that the pitch is greater than in any of the synclines described above. This is due to the abrupt termination of the syncline at the south against the end of a steeply pitching antiline. This deflects the strike at almost a right angle, and the pitch practically passes into the dip of the southern limb.

The strata exposed are those of the Greenbrier, Mauch Chunk, Pottsville, Allegheny, and Conemaugh formations.

#### CONCLUSIONS.

The rocks of the Maryland coal district are unaltered sediments which have been thrown into a series of open, slightly unsymmetrical folds with axes trending toward the northeast and southwest. The region presents a structure which is similar to that of the adjacent regions on the northeast and southwest, but different from the adjacent regions on the southeast and northwest. With each of the latter

it has certain points in common, being transitional between them. While on the whole it has within itself a marked individuality; yet too it has within itself certain divergent types which render it capable of division into structural sub-provinces.

The unit of structure is the fold. The anticline and the syncline are from one point of view complementary. Yet in describing a region which, like this, is composed of alternating anticlines and synclines, either might be ignored. Each syncline might be considered as extending from one anticline axis to the next; or each anticline, as from one synclinal axis to the next. The most rational and consistent way of dividing a region into anticlinal areas and synclinal areas would be to draw the line between the anticline and the syncline where the surface of any bed changes from an upward to a downward concavity. This would be along the line of greatest dip. There are two objections to this:—first, the difficulty of finding a fairly continuous and definite line of greatest dip; and second, the fact that in this region the anticlinal crests are very sharp so that such a division would throw almost all of the region into the synclinal areas. It has been found that the line of outcrop of the base of the Pottsville formation on the crests of the Pottsville ridges, and the crests of the Pottsville ridges themselves, approximately coincide in all parts of the county, and in many regions coincide with the zones of steepest dip. Therefore the anticlines and synclines have been separated on these lines for the purposes of this discussion. The method has the merit of giving the divisions not only a structural but a topographic and geologic unity.

The major folds situated in part in the region under discussion are seven; four of them being synclines, and three, anticlines. There is a long syncline (the Georges Creek-Potomac syncline) forming the eastern boundary of the coal district. This is succeeded on the west by a long anticline (the Deer Park anticline) which extends from near the northeast to the southwest corner of the district. West of this are two synclines (the Castleman syncline at the north and the Upper Yonghiogheny syncline at the south) which are disconnected

by a low uplift and are neither quite in line nor quite parallel. The axis of the latter is situated farther to the northwest, and its direction is nearer north and south, than the axis of the former. West of these two synclines are two anticlines (the Accident anticline at the north and the Cranesville anticline at the south) which, like the synclines last described, are also disconnected, and whose axes are both out of line and divergent. The discrepancy in the position and direction of the axes is similar to that of the axes of the above mentioned synclines, but is even greater in amount. Northwest of these anticlines is a syncline (the Lower Youghiogheny syncline). The Upper Youghiogheny syncline, from its position flanking the Deer Park anticline on the west, would seem to be more closely related to the Castleman than to the Lower Youghiogheny syncline. But it is structurally more closely related to the latter, as it is joined with it at a point on the axis 200 feet lower than with the former; and is a fold of the same broad unsymmetrical type.

Faults are small, infrequent, and inconspicuous. They do not affect the areal distribution of the formations, or the general character of the structure.

The folds are in general unsymmetrical, the steepest dips being on eastern limbs of the synclines and western limbs of the anticlines. In other words, the northwestward dips are steeper than the southeastward. This is in general true throughout the entire Appalachian province. The amount and the regularity of the dip decrease from the southeastern to the northwestern part of the district. The amount of pitch increases in the same direction. This regular change in the dip and pitch from the southeast to the northwest entirely changes the general character of the structure. The continuation of the change beyond the limits of the region in either direction makes it a transition zone between two radically different structural provinces. To the southeast and east is what has been designated the *Valley Region* of the *District of Open Folding* of the *Appalachian Province*, while to the northwest is the *Plateau Region* of the same district. The former is characterized by the canoe-shaped syncline and the

cigar-shaped anticline. The latter is characterized by the spoon-shaped syncline and the domed anticline. The eastern edge of the Georges Creek-Potomac syncline forms the western boundary of the former region. The eastern edges of the Accident anticline and the Upper Youghiogeny syncline form the eastern boundary of the latter region. The intervening area, comprising in Maryland the Georges Creek-Potomac syncline, the Deer Park anticline, and the Castleman syncline, is transitional between them.

### THE GEOLOGIC HISTORY OF THE MARYLAND COAL MEASURES.

#### EARLY PALEOZOIC PERIODS.

At the beginning of our record of geologic history large parts of what is now the continent of North America were covered by the sea. Land areas existed in what is now Canada and probably along a belt near the present Atlantic shore. These lands grew irregularly by elevation, and were worn away by the processes of erosion which are now attacking the land surfaces everywhere. The sea was fed by the waste of the eroded land, and shallowed and narrowed because of receiving these sediments.

The details of this early history are complex and varied. The uplift of the land was sometimes rapid and consequently large amounts of sediment were furnished to the sea within short periods. At other times the land-surface stood near the sea-level for long intervals, and then the sediment which reached the sea was fine in texture and small in volume. The land itself was sometimes submerged beneath the sea so that marine sediments were spread over the old land-surface. The sea-bottom was at other times raised above the water-level and the recently formed strata were eroded and redeposited.

There is very little positive evidence as to what took place within the Maryland coal region during the early Paleozoic periods as no rocks older than the Silurian and Devonian outcrop within the Coal Measures district. The character of the rocks to the east of the coal



district shows, however, that the region was submerged and was receiving sediments from the land mass to the eastward. The character of the later Silurian and early Devonian deposits, which are largely limestones, suggest that this land was near base-level, forming a broad low plain from which little sediment was derived. Gradually the continent rose, initiating erosion and causing muddy sediments to reach the sea. The continent was, however, a lowland until the middle of the Devonian when a very marked uplift of the land area east of the Devonian sea began which resulted in the growth of a great highland area. Erosion now became active and a vast amount of sediment was furnished, forming a great Coastal Plain which grew westward by the gradual filling of the sea and eastward by the reduction of the land to an even plain over which rivers meandered and spread the coarser part of their burden. Conditions little understood but which resulted in the formation of a great series of red and green sandstones, in which marine fossils are usually absent, mark the close of the Devonian period. It seems probable that the waters of this time which extended over the northern Appalachian region must have been shallow and for the most part cut off from the main ocean. A time evidently elapsed during which almost uniform conditions prevailed.

#### EARLY CARBONIFEROUS OR MISSISSIPPIAN PERIOD.

The change from the Devonian to the Carboniferous sediments in the region under discussion is of great lithologic abruptness. The surface is so sharp as never to be mistaken. Whether or not it is marked by an unconformity is a question which cannot at present be decided.

#### *The Pocono Epoch.*

According to Mr. Bailey Willis<sup>1</sup> the beginning of Carboniferous time was accompanied by a slight submergence and a tilting of the coastal plain toward the west. The red sediments which had been

<sup>1</sup> Paleozoic Appalachia; Md. Geo. Survey, vol. iv, p. 65.

supplied to the sea during late Devonian time failed; either because the deeply oxidized residual which had furnished them was exhausted or because transportation to the open sea was prevented by the submergence. At the same time the coarse and cleanly washed quartzose sediments which had been accumulating in the beaches and sand-flats of the Devonian coastal plain were delivered rapidly to the waters of the open sea and were spread as a broad sheet of conglomerate and sand. These beds form the Pocono sandstone. Some of the beaches and lagoons of earlier times were probably then entombed and preserved without destruction in the mass of partly transported and re-deposited material. This made the sediments of the Pocono of great complexity of character and discordance of bedding. The great and rapid variations in thickness of the formation find explanation in previous irregularities of the sea-bottom, in local differences in the amount of material at hand, and above all in the varying distance from shore.

Interbedded with the sandstone and conglomerate are beds of fine shale, some of which carry abundant marine fossils. These are probably the most shoreward representatives of the normal marine sediments which form the Waverly group in Ohio where they contain the remains of flourishing marine life.

In Allegany county there is little apparent difference between the highest Devonian and the lowest Carboniferous sediments except in color and coarseness. In each case the sediments are almost wholly of quartzose materials and indicate shallow water and mountainous land conditions. Cross-bedding, ripple-marks, and thin coal seams all attest a preparatory step toward the marshy condition of the Coal Measures.

Pocono time was marked by rapid submergence and the rapid delivery to the sea of the beach accumulations of previously washed and sorted material. The duration of Pocono time was probably not long.

*The Greenbrier Epoch.*

The beginning of Greenbrier time was marked by a sudden decrease in the amount of sedimentation. The waters of the Appalachian sea became clearer and deeper and little or no arenaceous sediments were deposited. These waters teemed with marine life, and by the agency of these organisms, aided perhaps by chemical precipitation, beds of limestone were laid down. The argillaceous character of most of the limestone, and the presence of interbedded strata of red shale indicate that land was near enough to furnish some detritus. The nature of this sediment shows that the land had a deeply disintegrated surface and that the shore-line was sufficiently embayed or beach-bound to prevent the coarser material from reaching the open sea. It is probable that the submergence which brought the deep clear ocean waters into the region converted the lower courses of the rivers into estuaries in which the coarser part of the land-waste was held.

The "siliceous limestone" or calcareous cross-bedded sandstone at the base of the Greenbrier records that stage of the submergence when the last of the pebbly beaches disappeared below the sea and clear marine waters first extended over them. The cross-bedding in this rock was the work of the undertow and tides on tops and sides of these already submerged beaches. They are a lithologic transition from the Pocono to the Greenbrier, but belong most positively to the age of the latter.

The absence of fossils in these beds is to be explained by the submergence and the accompanying eastward transfer of the shore-line having been too rapid for the fauna to accompany it.

Shortly after this first invasion of marine waters from the west, the ponded Pocono rivers succeeded in clearing their mouths of the marine waters and poured an accumulation of muddy sediment into the sea. Then were deposited the red and green shales and thin argillaceous limestones of the Middle Greenbrier. It is probable that these deposits record a halt in the subsidence.

The purer, more thickly-bedded limestones which predominate in the upper part of the Greenbrier formation are the record of a renewed and continued subsidence which lasted throughout the remainder of Greenbrier time. Marine conditions then existed for a long period and over a wide area. From time to time muddy sediment reached the sea but it did not interfere with life, for the limestones and shales are both fossiliferous.

#### *The Mauch Chunk Epoch.*

The beginning of the Mauch Chunk epoch was marked by the invasion of that part of the sea in which the present Mauch Chunk shales of Maryland were deposited by a great volume of muddy sediment similar to that which from time to time reached it during the Greenbrier epoch. The clear marine waters and the marine fauna were driven away and a great thickness of mud and sand was rapidly deposited. This was occasioned by an elevation of the continent sufficient to quicken erosion and to bring the region under discussion within the zone which could receive muddy sediments; but not enough to submerge the beaches or to deliver coarse unsorted material to the waves. The conditions of Catskill time were repeated. The already deeply weathered and oxidized soil was stripped off and carried to the sea but on the way the coarser material lagged behind and was accumulated in flood-plain and coastal-plain sediments which were not to receive their final deposition until the next epoch.

#### LATER CARBONIFEROUS OR PENNSYLVANIAN PERIOD.

The change from early Carboniferous to late Carboniferous sediments is very marked. The open-water conditions which had prevailed even to the close of the Mississippian period were now gradually replaced by successive marshes in which the great accumulations of vegetable débris out of which the coal is formed took place.

*The Pottsville Epoch.*

The beginning of Pottsville time was marked by the change from the deposition of fine oxidized sands and clays to that of much coarser and fresh sands and gravels. It was such a change as accompanies a submergence and seaward tilting of an old land surface. The coastal-plain accumulations were rapidly swept into the sea and re-deposited without resorting.

The history of Pottsville time is complex, varying much within short intervals, not merely from time to time, but from place to place.

The lowest beds of the Pottsville in Maryland are much younger than those of the regions to the northeast and southwest. It is thus evident either that there was no sedimentation in Maryland during the earliest Pottsville time, or that any such sediments as ever existed have been eroded, or that the oldest Pottsville sediments of these other regions are contemporaneous with part of the Mauch Chunk. This question has been discussed by Mr. David White<sup>1</sup> who, while he regards the present evidence as inconclusive, is inclined toward the first explanation.

Mr. White<sup>2</sup> believes that Mauch Chunk time terminated with the existence of a broad coastal plain bordering a vast expanse of shoals, ferruginous mud-flats and shallows extending across the greater part of the northern coal fields. The Maryland region was far out in the latter belt. Then, according to Mr. White, orogenic movement began and the earth's crust was warped so as to form a trough to the east of the present coal area of Maryland while on either side of the trough the earth's crust was elevated. This brought large areas of the newly deposited Mauch Chunk sediments above sea-level, and also accelerated erosion and the redeposition of the Mauch Chunk coastal plain sediments in the eastern region. The oldest Pottsville was thus deposited, but no sediments were then laid down in the

<sup>1</sup> The Stratigraphic Succession of the Fossil Floras of the Pottsville Formation in the Southern Anthracite Coal Field, Pennsylvania. 20th Ann. Rept. U. S. Geol. Survey, part II, pp. 749-928.

<sup>2</sup> Bull. Geol. Soc. Amer., vol. xv, 1904, pp. 280-281.

Maryland region. Gradually the trough deepened and at the same time extended westward till finally, in Sharon time, the area of deposition reached what is now the Maryland coal regions. From this time on until the deposition of the youngest Pottsville, this region was within the area of deposition, and the course of events was, as has already been narrated by the author as follows:<sup>1</sup>

“In the Maryland region the beginning of Pottsville deposition was marked by the laying down of a thin sandstone, following the cessation of the deposition of red sediments and possibly following a still later period of erosion.

“The next episode was the invasion of fine lagoon and marsh sediments producing a succession of fine sandstone, shales, and coal seams. These beds carry the very distinctive Sharon flora and are hence to be correlated with the widespread Sharon coal-group. The existence of these beds implies an interval of quiescence of considerable duration which extended over a wide area.

“The Connoquenessing sandstones indicate that Sharon time was followed by a tilting of the continent to the seaward which submerged the marsh deposits and spread over them not only part of the barrier beaches behind which they had accumulated but the sands and gravels which had been accumulating along the flood-plains of the rivers. About the middle of Connoquenessing time there was a short period of quiescence during which the Quakertown coal with its accompanying shales was spread in a great marsh which extended not only over the region under discussion but over the greater part of what is now western Pennsylvania, eastern Ohio, and northern West Virginia. But immediately after the deposition of the coal the conditions which existed during early Connoquenessing time were resumed and continued with great uniformity.

“After the deposition of the Connoquenessing sandstone, the present Maryland coal region again became a great coal marsh in which the Mercer coals and shales were laid down. This marsh extended

<sup>1</sup> The Physical Features of Garrett County; Md. Geol. Survey, 1902, p. 170.

over the whole of western Maryland and the larger part of western Pennsylvania, northern West Virginia and eastern Ohio. In its more minute details the history of the Mercer stage was complex. In some places as many as three coals were deposited, while in others there was only one. In some regions two limestones were deposited, but both of them are absent in Maryland.

“Another great sandstone, the Homewood, was spread over the Mercer shales and coals. The deposition of this sandstone probably records a gradual subsidence during which the barrier-beach was driven landward, burying the Mercer marshes. The culmination of this movement terminated Pottsville time.”

#### *The Allegheny Epoch.*

Allegheny time began with the period of quiet which succeeded the submergence during which the Homewood sandstone was laid down. As soon as this submergence ceased the broad area of sand with its surface in the littoral zone was converted into a swamp in which was formed the Brookville coal. The formation of this coal was followed in some portions of the field by a very slight submergence which permitted the accumulation of mud. When this submergence ceased another swamp was formed in which the Clarion coal was formed. In those localities where there was little or no submergence during this interval the Brookville and Clarion coals are represented by a single seam. In such localities the coal represents *both* the Brookville and the Clarion. In some other localities one or the other may be and probably is absent, because that spot was the location of an island or a lake within the marsh. The Clarion sandstone which overlies the Clarion coal represents a crustal submergence of broad extent and considerable magnitude, which resulted in spreading the sands of the barrier-beach and of the flood-plains over the marsh accumulations. This was followed by a greater submergence which brought the entire district into the region of the accumulation of fine sediments. The shales which overlie the Clarion sandstone date from this time, as does also the Vanport or “Ferri-

ferous" limestone. It is evident that this submergence was greater toward the north and northwest, for the limestone carries a marine fauna only in Ohio, Pennsylvania, and the northern part of Maryland and West Virginia, while in the southern part of West Virginia and in the adjacent part of Maryland it is of a fresh or brackish water type. As soon as the bed of shales in which the Vanport limestone is included was built up to the littoral zone, a marsh began to develop upon its surface and the Lower Kittanning coal was formed. The coal seam known as the "Split-six" records the development of a local marsh dating between the age of the Vanport limestone and that of the Lower Kittanning coal. The area of the Lower Kittanning marsh covered a region including what is now the bituminous coal fields of Pennsylvania, Maryland, West Virginia, Ohio, and probably part of Kentucky. Large areas within this marsh became submerged enough for the Lower Kittanning coal to be covered by a few feet of mud. The Middle Kittanning coal was laid down upon this shale, or in the absence of the shale, directly upon the Lower Kittanning coal.

The Middle Kittanning coal was almost immediately submerged to the zone of the rapid accumulation of sand, and cross-bedded sands were spread over it. Upon this new surface local marshes immediately developed in which the Upper Kittanning coal was formed.

The succeeding time interval was characterized by the rapid and somewhat irregular accumulation of sandstone and shale. The local variations are probably due to differences in source of supply and in stream action. There was probably a moderate submergence after the formation of the Upper Kittanning coal attended by uplift and increased erosion in the interior. The local occurrence of the Lower Freeport limestone in this interval suggests local deeps or quiet places along shore which land detritus did not reach.

The Lower Freeport coal records the next period of widespread tranquillity. The marsh in which this coal was formed does not appear to have been as uniform and unbroken as the Kittanning marshes.



The deposits which cover the Lower Freeport coal are in some places shale and in others sandstone. This indicates variations in amount of submergence, local differences in supply, or both.

The variable succession of events during which these shales and sandstones were laid down was followed by greater quiet. During this interval only fine sediments were accumulated. These consist in some places of limestone, in others of iron carbonate, and in others of fire-clay. The lower Freeport limestone and the Bolivar fire-clay date from this time.

Then came an invasion of rank vegetation, and the Upper Freeport coal was formed. The Upper Freeport marsh was one of great extent and uniformity. According to Professor I. C. White<sup>1</sup> this coal is more regular and persistent in Pennsylvania than elsewhere, although it is workable over large areas in West Virginia and Ohio. The destruction and burial of the vegetation in this marsh ended Allegheny time.

#### *The Conemaugh Epoch.*

Conemaugh time began with a general and widespread submergence which spread the previously formed beach accumulations over the Upper Freeport coal, and formed the Mahoning sandstone. This marine transgression was of wide extent and must have been of long duration. During its progress the Upper Freeport marsh was being driven eastward so that the Upper Freeport coal of the most eastern basins of Maryland, West Virginia, and Pennsylvania is contemporaneous with part at least of the Mahoning sandstone of Ohio. During the middle of Mahoning time there were developed in parts of this region small marshes in which the Mahoning coal was formed. During the formation of this coal the submergence must have ceased long enough for the land detritus to be built into a beach. The predominance of shale over sandstone at the horizon of the Upper Mahoning sandstone in this region indicates that the supply of material in the barrier-beach was not very great or else that the streams had

<sup>1</sup> Bull. 65, U. S. Geol. Survey, 1891, p. 147.

filled their channels with debris to such an extent that they were carrying a large amount of unsorted material to the coast.

Mahoning time ended with the deposition of the last sand. The submergence had reached such a point at this time that only very fine material was reaching the sea. As soon as sedimentation caught up with this submergence a marsh of very broad extent was spread over the newly made flats and the Brush Creek coal was formed. The Brush Creek marsh covered all of the coal region of Maryland west of Cumberland, most of southwestern Pennsylvania, all of eastern Ohio, the greater part of West Virginia, and part of Kentucky. That conditions were extremely uniform over the greater part of this area is shown by the almost entire absence of variation in the character of this coal. The marsh was so large that the vegetation grew, for the most part, in clear water and consequently the coal is remarkably free from impurities.

The barrier behind which the Brush Creek marsh existed was low and contained a small amount of sand compared with the area of the marsh. Consequently when the submergence which terminated the formation of the coal took place, the overlying bed was not formed from the sand of the barrier-beach driven inland by the waves. But marsh and beach together were submerged under the waters of the open sea and the first covering which the coal received was of shale. As soon as from five to eight feet of shale was deposited the marine life which had been living farther from shore colonized this newly-made sea-floor, and flourished there. In this way the Lower Cambridge limestone was spread as a broad continuous sheet at a very uniform distance of about six feet above the Brush Creek coal. Then there was a continental elevation which increased the amount of sediment, rendering the conditions more and more unfavorable for marine life until as the deposits became a sand, the fauna entirely disappeared. The Buffalo sandstone was then rapidly laid down. This sandstone was evidently derived from a partly sorted mass of sand, which during the formation of the Lower Cambridge limestone, had been deposited on a coastal plain which lay to the eastward of that

part of the Carboniferous sea in which the limestone was deposited. Still farther to the east lay a low continent whose surface was being deeply disintegrated by aerial agencies.

The next step in the history of the sediments was the submergence of the continental mass, probably accompanied by a seaward tilting. This brought the last of the coastal-plain sands below the reach of the waves, admitted the marine waters to the Maryland region, and delivered the red residual soil of the old land surface to the sea. The result was the deposition of a series of red and gray shales and marine fossiliferous limestones. The Upper Cambridge limestone, represented in Maryland by two limestone bands 17 feet apart, belongs here. The red shales carry some marine fossils.

The sea was gradually being driven back by the growth of the land and soon the shore was transferred westward beyond the Maryland region. Then a great marsh was spread as far west as the Monongahela river, and in it the Bakerstown coal was formed.

Over the Bakerstown coal the rivers spread a deposit of cross-bedded sand which is now known as the Saltsburg sandstone. As this sand was extended seaward the land sank until the coarser deposits failed to reach the coast, and a deposit of shale was laid down along the shore. A coastal plain was thus built up of fine material, the coarser land-débris being held back in the estuaries and on the flood-plains of the overburdened streams. The coastal plain then was brought to sea-level, a barrier beach was formed around its outer edge, and a great marsh was enclosed within. The Friendsville coal was formed in this marsh. The extent of this marsh was practically the same as that of the marsh in which the Brush Creek coal was formed. The history of the Brush Creek marsh was repeated. The entire coast,—barrier beaches, marsh, and estuaries were submerged below the open sea, thus cutting off the supply of terrestrial débris from this region and admitting a marine fauna, by the agency of which the marine Ames limestone was formed. It must be noted that in this case the invasion of the marine fauna was so rapid that the limestone rests directly on the coal.

This submergence was of short duration. The land mass was elevated, bringing muddy sediments into the region under discussion, and the marine fauna was driven to the west. The elevation of the sea-floor and the sedimentation from rivers resulted in a deposit of muddy and sandy material over the continental shelf. Soon these deposits reached the ocean level, and a marsh was inclosed in which the Elklick coal was formed. This coal is thin and very variable in Maryland, but whether this is due to the conditions of its formation or to its subsequent erosion is not known. It seems probable that the elevation which rendered the formation of the coal possible continued to some extent during and after its formation, and that thus not only was the surface of the coal somewhat eroded but the shore was transferred far to the westward, and the continent sufficiently raised so that stream action was greatly accelerated. This elevation terminated the marine history of this region and of the entire northern Appalachian coal fields.

It is also probable that from this time on differential uplift played a greater and greater part. The warping of the crust increased the elevation more rapidly in the interior than on the coast and barriers due to differential uplift kept back the sea. The thick deposits of sand and gravel which were then laid down form the Morgantown sandstone, the base of which records the break either between the middle and upper Carboniferous<sup>1</sup> or between the Carboniferous and Permian.<sup>2</sup>

It seems probable that when the Morgantown sandstone was deposited the Appalachian gulf ceased forever to be marine. This was due in part to the decrease in area of the gulf, especially at the northeast end, in part to the general shallowing of the gulf throughout, and in part to the fact that the repeated seaward tiltings had increased the gradient of the westward-flowing stream, reducing at the same time that of those flowing to the east, and had thus diverted a large amount of drainage from the Atlantic into the gulf.

<sup>1</sup>I. C. White, Bull. 65, U. S. Geol. Survey, 1891, pp. 19, 70.

<sup>2</sup>I. C. White, Amer. Geol., vol. xxi, 1898, p. 51.

The Morgantown sandstone is the product of a great elevation which transferred the previously accumulated coastal-plain deposits into the sea, eroding and then burying the marine and coastal-marsh deposits which had been formed in the time just passed. This elevation was in large part differential, and the land areas were elevated more than the sea and coast. As far as the coast was concerned the elevation did not continue long. In fact it is highly probable that after a very short time the coast began to be submerged. Due in part to this reverse movement which may have involved to some extent the whole land-mass, and in part to the fact that erosion was counteracting the effect of elevation, the sediments gradually became finer. The upper part of the Morgantown sandstone grades into a sandy shale, in which is included the Lonaconing coal, the product of a marsh which existed toward the close of Morgantown time.

The red and green shales which frequently overlie the Morgantown sandstone record a time in which a large part of the land lay near base-level and only the finer sediments reached the sea. Toward the latter part of this epoch a fresh water limestone (the Clarksburg limestone) was laid down. The next step was the development of a very extensive coal marsh in which the Franklin or Little Clarksburg coal was formed.

The Connellsville sandstone records another seaward tilting which spread the sand and gravel, which had failed to reach the sea during the preceding time, over the finer deposits.

Connellsville time was followed by a submergence and a time of quiet in which little sand and no gravel passed the shore-line. Fine sands alternated with clays and limy muds. Several coal marshes were developed but these were of local extent. The epoch was marked by gentle and somewhat irregular submergence and slow sedimentation. Finally the bottom of the greater part of the gulf was brought near water level and the Conemaugh epoch ended.

#### *The Monongahela Epoch.*

Monongahela time began with the growth of vegetation on the even surface which was formed in the Appalachian gulf during the

closing days of Conemaugh time. This was the Pittsburg marsh and in it was formed the Pittsburg coal. The Pittsburg marsh was of long duration, and conditions were of remarkable uniformity in its various parts. Such changes as took place, for example, the interruption of vegetable growth by the deposition of mud, extended over broad areas. The epoch of the Pittsburg coal was ended by a very gentle and widespread submergence without tilting, which brought the marsh below the waters so that it was covered by fine mud. That the land areas shared in this submergence is shown by the fact that coarse material is not included in this covering. The waters soon became deep and clear enough for a deposit of limestone (Redstone) to form. The formation of this limestone brought the sea-bottom again near the surface of the water and a marsh developed in which the Redstone coal was formed. The next step was another gradual submergence which involved land and sea areas alike, and resulted in the deposition of more shale and limestone. This limestone (Sewickley) is somewhat irregular in extent and occasionally grades laterally into the shale. The water was not everywhere deep enough, or far enough removed from the mouths of rivers for limestone to form.

After the formation of the limestone the land rose and a coal marsh formed and migrated westward along the receding shore. In this marsh the Sewickley coal was formed. The presence in some regions of two Sewickley coals separated by an interval of shale indicates that the Sewickley marsh was locally submerged, and that the last stages of the marsh were spread in some regions directly over its old surface, and in others over the muds which had there buried the older part of the marsh. The Maryland region was one of the latter type.

After the formation of the Upper Sewickley coal the sea-bottom sank with evidently some differential movement. The submergence was probably greater in the region which is now western Pennsylvania and Ohio than in West Virginia and Maryland. In Maryland and West Virginia shale and sandstone were deposited, while in Ohio

and western Pennsylvania the deposits were of limestone and shale. Immediately after the deposition of the main mass of limestone or of sandstone, a coal marsh was locally developed and in it the Uniontown coal was formed. Submergence followed this, and a deposit of shale and sandstone was laid down. Then the waters became deeper and the Waynesburg limestone was formed. Subsequently the waters became extremely shallow and a marsh was developed, in which the Waynesburg coal was formed. The final interruption of vegetable growth and burial of this swamp ended Monongahela time, and with it the Carboniferous.

#### THE PERMIAN PERIOD.

##### *The Dunkard Epoch.*

Dunkard time began with the gentle submergence which buried the Waynesburg marsh. The events of this epoch in Maryland are not well known because the rocks are not well exposed. It was evidently a time of gentle and continuous submergence, and of slow sedimentation in fresh or brackish water.

There is no record preserved, in the Maryland rocks, of the last half of the Dunkard epoch. Sedimentation probably continued in this region until the Appalachian gulf was finally filled. This ended the Paleozoic sedimentary record in this part of the world.

#### THE MESOZOIC AND CENOZOIC ERAS.

##### *The Pre-Quaternary Periods.*

The Maryland coal district, like the rest of the Appalachian region, was a land area during the entire Mesozoic and Cenozoic time. It received no sediment, but was a region subject to uplift, folding, and erosion. There is no chronologic record of the process of folding to which these rocks have been subjected. The present structure shows the final result of the folding without any historical details. The folding took place at no great depth below the surface and was not accompanied by any sudden or violent movement. It may have occurred at one or at several periods.

*The Quaternary Period.*

Quaternary time in the district was a period of erosion accompanied by the local and temporary deposition of sediments along the water courses and behind barriers of resistant rock. The minor details of this history were complex and no adequate record of them has been preserved.

The history is one of continued erosion retarded here and there by the shifting barriers of sandstone and conglomerate ledges across the streams. Behind these barriers small deposits of sand and clay accumulated. Probably at no time in the Quaternary did conditions over the region as a whole differ much from those existing at present.

In the review of the sedimentary record we have seen how elevation and subsidence followed each other with varying rapidity while the large volume of Paleozoic sediments was being deposited. It seems probable that during this time some lateral pressure was also exerted upon these sediments, producing incipient antilines and synclines. It was not, however, until near the close of Paleozoic time that structural changes of exceptional magnitude were manifested throughout the entire Appalachian province. The strata which had been deposited upon each other in an approximately horizontal position were then squeezed and folded to an enormous degree, the forces being applied laterally in a direction perpendicular to the course of the present mountain ranges. How long this compression continued is not known. Suffice it to say that the earliest Mesozoic records show a new axis of drainage and that most of the rivers, instead of flowing to the west as the Paleozoic rivers had done, were then flowing to the east.

That there has been vertical upward movement of importance since the close of Paleozoic time is evidenced by the development of well-marked physiographic features, such as the Cretaceous and Tertiary peneplains and the various river terraces found along the streams of the county.



# CORRELATION OF THE FORMATIONS AND MEMBERS

BY

WM. BULLOCK CLARK AND GEO. C. MARTIN

---

The coal deposits of Maryland constitute part of the series of Coal Measures of the northern Appalachian field. They have frequently in the past been considered by geologists independently of the deposits of the same age in the adjacent states of Pennsylvania and West Virginia and a local classification of formations and coal beds has been at various times proposed. This has been in large measure due to the fact that the study of the Maryland Coal Measures has been mainly confined to the Georges Creek basin, a deep synclinal trough that presents the only full representation of the formations of the Coal Measures within the limits of the State, but which is entirely detached from the main areas of the Coal Measures in the adjoining states. Very little consideration has been given in the past to the less complete series of coal deposits found to the westward in Garrett County for the reason that these relatively less important basins have been left practically undeveloped until within the last decade.

The authors of the present report have been engaged for several years in a study of the Coal Measures of Maryland, and are satisfied, both from an intimate comparison of the sequence of deposits found represented in Maryland with those of other areas and from the continuity of certain of the beds with those in adjacent regions of Pennsylvania and West Virginia, that the same conditions and the same seams of coal earlier described in adjacent areas are present in Maryland and that these names must be adopted in classifying the Mary-

land deposits. The accuracy of these conclusions are further attested by a study of the floras and faunas which are extensive and highly distinctive, and prove the equivalency of many of the horizons beyond all question. The authors have been much impressed from this comparison of deposits and the fossil remains contained in them with the wide geographic range of even the minor divisions of the Coal Measures of the northern Appalachian field, many of the beds being traced without difficulty over thousands of square miles with very little change in physical characteristics. Some of the coal beds especially show marked typical features that admit of their ready determination. This is seen not only in the physical constitution of the coal but in the characteristic position and nature of the partings.

The Coal Measures of the northern Appalachian field, as indicated in the preceding discussion, have been divided into the following formations:

TABLE.		
Group.	Formation.	Age.
	Dunkard.....	Permian (?)
Coal Measures	Monongahela..... Conemaugh..... Allegheny..... Pottsville.....	} Upper Carboniferous (Pennsylvanian).

These formations, together with their subdivisions, are described in the succeeding pages. Characteristic sections accompany the text, the character of the deposits being represented in the usual conventional manner. That portion of each section which was concealed is left blank. As each section is carefully drawn to the scale of 1 inch to 200 feet it will be an easy matter to determine the thickness of the several members. Here and there slight changes in the character of the material as compared with typical sections of western Pennsylvania are apparent, but in general the character and position of the several beds are remarkably similar. Some differences in the thickness of the individual members appear but they conform for the most part to the recognized changes that affect the eastern margin of the northern Appalachian field.

POTTSVILLE FORMATION.

*Composition and Relations.*—The strata here referred to the Pottsville formations consist of conglomerates, sandstones, shales, fire-clays, and coals which reach from 325 to 380 feet in thickness. The thickness is apparently greatest in the southeastern part of the region under discussion and decreases toward the north and west.

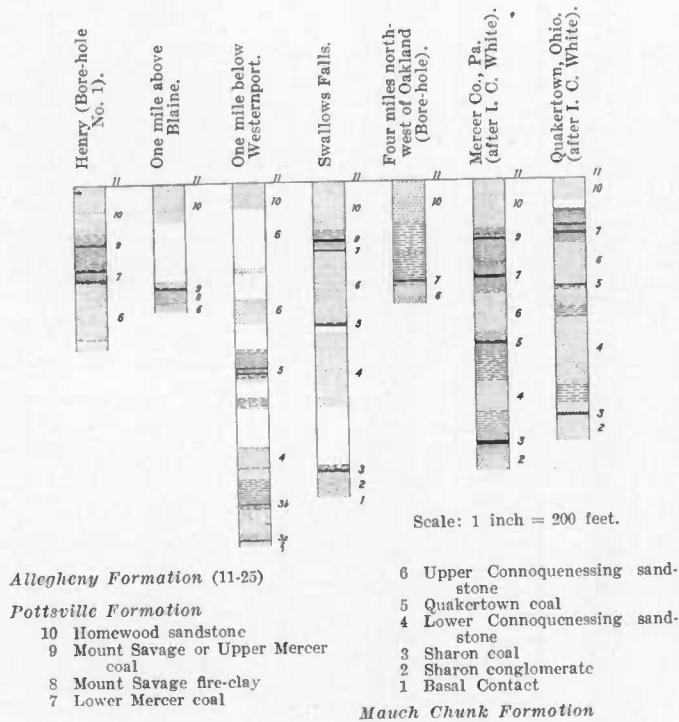

FIG. 21.—Columnar Sections of the Pottsville Formation.

The Pottsville formation in Maryland is of the *western Pennsylvania type* and lacks the greatest thickness shown in the southern anthracite field of Pennsylvania, where the formation was named. Comparison of the formation, both as a whole as well as the individual members, with the strata exposed there can at present be made only on paleontological evidence. This is not at this time sufficient

for the complete correlation, and consequently the present discussion will be restricted to a consideration of the relations of the Maryland deposits with those exposed and named in western Pennsylvania. Professor Stevenson, in a recent and very elaborate discussion of the stratigraphy and correlation of the Pottsville,<sup>1</sup> has grouped the members into two subformations; the Upper Pottsville or Beaver of Lesley, and the Lower Pottsville or Rockcastle of Crandall. The former includes only that part of the Pottsville which is present in Maryland with the addition of the Sharon sandstone which should, perhaps, be included with it. It would therefore be possible, and may be advisable in future and more detailed work over broader areas, to map the Beaver formation as a division of the Pottsville group or as a subformation of the Pottsville, in which case the beds present in Maryland would be called the Beaver formation.

The U. S. Geological Survey, in its Piedmont folio, adopted the name Blackwater formation for the deposits of this horizon, but included also, according to Mr. David White<sup>2</sup> and Professor Stevenson,<sup>3</sup> about 195 feet of the strata belonging to the Lower Pottsville.

*Basal contact* (1).<sup>4</sup>—The Pottsville formation everywhere rests on the red and green shales and sandstones of the Mauch Chunk formation. There is some local discordance of bedding, indicating an unconformity which, according to the physical and floral proof of Mr. David White, represents an overlap and probable erosion interval which extends over the greater part of the area of the northern Appalachians.<sup>5</sup>

<sup>1</sup> Carboniferous of the Appalachian Basin. Bull. Geol. Soc. Amer., vol. xv, 1904, pp. 37-210.

<sup>2</sup> Deposition of the Appalachian Pottsville. Bull. Geol. Soc. Amer., vol. xv, 1904, pp. 267-281.

<sup>3</sup> Carboniferous of the Appalachian Basin. Bull. Geol. Soc. Amer., vol. xv, 1904, p. 190.

<sup>4</sup> The numbers used in this paper correspond to those used on the figures. There is no intention to give the coal seams and other members of the Coal Measures of Maryland a permanent *numbering*.

<sup>5</sup> Deposition of the Appalachian Pottsville. Bull. Geol. Soc. Amer., vol. xv, 1904, pp. 267-281.

*Sharon sandstone* (2).—A sandstone which probably nowhere in Maryland exceeds 25 feet in thickness, and is sometimes absent, is generally found at the base of the Pottsville formation. It is considered to represent the Sharon conglomerate because of its position conformably below the Sharon coal.

*Sharon coal* (3).—Good exposures of the strata at the base of the Pottsville are found one mile below Westernport, Allegany county, and in the gorge of the Youghiogheny river, below Swallow Falls, Garrett county. At each of these localities there are beds of coal in a series of shales which lie between the sandstone above mentioned and a much thicker and more massive overlying sandstone. Both from the stratigraphic position and from the evidence<sup>1</sup> of the abundant fossil plants, these beds are regarded as the equivalent of the Sharon coal group.

*Lower Connoquenessing sandstone* (4).—Overlying the shales of the Sharon group is a mass of very coarse, thick-bedded, white, sandstone, which from its position is evidently the equivalent of the Lower Connoquenessing sandstone of Lawrence county, Pennsylvania.

*Quakertown coal* (5).—Near the top of the Lower Connoquenessing sandstone and overlain by a similar thick-bedded sandstone is a coal seam which corresponds in stratigraphic position to the Quakertown coal of Quakertown, Pennsylvania. The seam named the Bloomington coal<sup>2</sup> was assigned to a stratigraphic position corresponding to that of the Quakertown coal; but under this appellation were also included at a few points coals that are now known to belong to the Mount Savage and the Clarion seams.

*Upper Connoquenessing sandstone* (6).—Overlying the Quakertown coal is a coarse white sandstone about 75 feet in thickness, which corresponds to the Upper Connoquenessing sandstone described by Dr. I. C. White, from Lawrence county, Pennsylvania.

<sup>1</sup> Mr. David White, after an examination of the fossils, has informed the authors that he considers them to belong to the horizon of the Sharon coal.

<sup>2</sup> The Physical Features of Allegany County. Md. Geol. Survey, 1900, pp. 115, 170.

*Lower Mercer coal* (7).—A very short distance above the top of the Upper Connoquenessing sandstone is a thin coal, which corresponds in its position with reference to the underlying and overlying beds to the Lower Mercer coal of western Pennsylvania.

*Mount Savage fire-clay* (8).—Above the Lower Mercer coal, or on top of the Connoquenessing sandstone when that coal is absent, is the Mount Savage fire-clay, so named from its typical development near the town of Mount Savage, Allegany County, Maryland. The bed consists of a mass of soft gray shale from 5 to 12 feet in thickness, which softens readily, on exposure to the weather, to a plastic, very refractory clay. As nodules in this mass, or replacing part or all of it, is the flint-clay, which differs from the plastic clay in not becoming plastic either by grinding or on exposure to the weather. The genetic difference between the two varieties is not known, and there seems to be no regularity in distribution between them.

*Mount Savage or Upper Mercer coal* (9).—Immediately above the Mount Savage fire-clay is a seam of coal varying in thickness from 2 to 4 feet. It is the seam which has long been known in the northern end of the Georges Creek basin as the Mount Savage coal, and is possibly the same as the Upper Mercer coal of Professor H. D. Rogers. The seam which was named the Westernport coal<sup>1</sup> in the southern Georges Creek basin is the same as this. The shales associated with this coal carry an abundant flora, which Mr. David White, after examination, informs the authors is identical with the Mercer flora.

*Homewood sandstone* (10).—A massive sandstone, varying in thickness from 30 to 100 feet, is found a short distance above the Mount Savage coal. This was formerly called the Piedmont sandstone. From its position between the Mercer coal group and the base of the Allegheny formation, it is evidently identical with the Homewood sandstone of Pennsylvania.

<sup>1</sup>The Physical Features of Allegany County. Md. Geol. Survey, 1900, pp. 115, 170, 171.

ALLEGHENY FORMATION.

*Composition and relations.*—The Allegheny formation consists of a series of sandstones, shales, limestones, and coal seams having a total thickness in Maryland of from 260 to 350 feet. The thickness is greatest in the southern and eastern parts of the area, in this respect corresponding to the Pottsville.

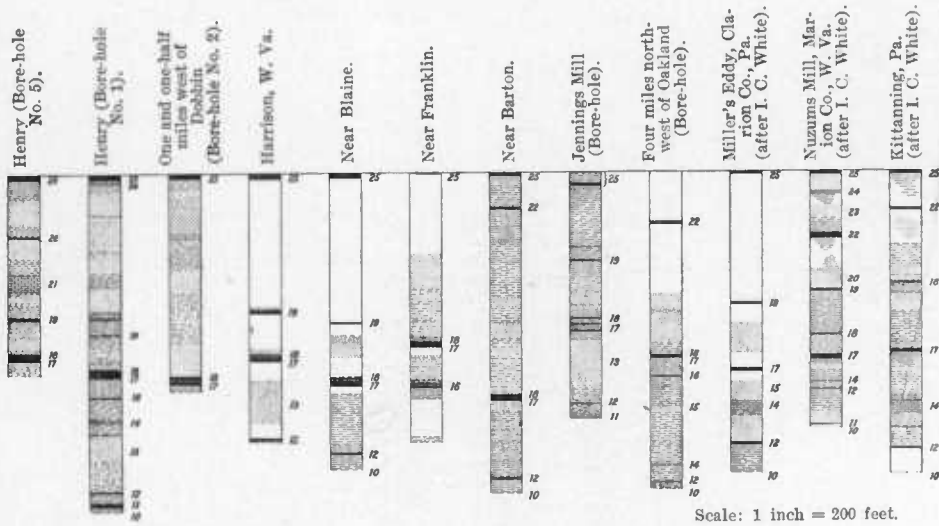

- Conemaugh Formation (26-44)
- Allegheny Formation
- 25 Upper Freeport coal
- 24 Upper Freeport limestone (Bohlar fire-clay)
- 23 Upper Freeport or Roaring Creek sandstone
- 22 Lower Freeport coal
- 21 Lower Freeport limestone
- 20 Lower Freeport sandstone

- 19 Upper Kittanning coal
- 18 Middle Kittanning coal
- 17 Lower Kittanning coal
- 16 "Split-six" coal
- 15 Kittanning sandstone
- 14 Vanport or ferriferous limestone
- 13 Clarion sandstone
- 12 Clarion coal
- 11 Brookville coal

Pottsville Formation (1-10).

FIG. 22.—Columnar Sections of the Allegheny Formation.

The name "Allegheny series" was proposed by H. D. Rogers in 1840<sup>1</sup> to include the strata from the lowest bed exposed at Pittsburg down to the "sandstones and conglomerate at the bottom of the coal formation." The type section is along the Allegheny river between

<sup>1</sup> Fourth Annual Report of the Geological Survey of the State of Pennsylvania, p. 150.

Pittsburg and Warren. In later usage the formation has been restricted by cutting off the upper part, which now constitutes the Conemaugh formation. The Allegheny formation was also known under the name of the Lower Productive Coal Measures or Lower Productive Measures. The U. S. Geological Survey, in its Piedmont folio, proposed the name Savage formation for the lower part of the Allegheny formation, including the Davis coal, and the name Bayard formation for the upper part of the Allegheny formation and lower part of the Conemaugh formation up to and including the Four-foot coal of the Potomac valley.

*Brookville coal* (11).—A seam of coal varying from 1 to 4 feet in thickness sometimes occurs at or very near the base of the Allegheny formation. This is in the stratigraphic position of the Brookville coal. It has been known in Maryland as the Bluebaugh coal, and was so called in the Report on the Geology of Allegany County.

*Clarion coal* (12).—A seam of coal approximating  $2\frac{1}{2}$  feet in thickness is found in an interval of from 12 to 30 feet above the Brookville coal, or, in the absence of that coal, about the same distance above the base of the formation. This seam corresponds in position to the Clarion coal. It has been hitherto known in Maryland as the Parker coal, and was so called in the Report on the Geology of Allegany County.

*Clarion sandstone* (13).—Separated from the Clarion coal by a thin series of shales, there is frequently a massive sandstone, which sometimes reaches as much as 70 feet in thickness. It is especially well developed along the Potomac river in Garrett county, where it can readily be mistaken for the Homewood sandstone. This sandstone is in the stratigraphic position and has the lithologic character of the Clarion sandstone of Pennsylvania.

*Vanport or Ferriferous limestone* (14).—A short distance above the Clarion sandstone, or the horizon for it, is a limestone a few feet in thickness. This limestone has been seen at only a few points in the southern part of Garrett county. At all of these localities it is evidently of fresh-water origin, and contains no fossils except Ostra-



coda. In the bore-hole four miles northwest of Oakland a thin limestone with marine fossils was encountered at this horizon. It is the position of the Vanport or "Ferriferous" limestone of Pennsylvania, and is possibly the equivalent of the Putnam Hill limestone of Zanesville, Ohio.

*Kittanning sandstone* (15).—The interval between the Vanport limestone and the next coal above is usually occupied by shale. In the bore-hole four miles northwest of Oakland, where this interval is large, it is occupied in part, however, by sandstone. This sandstone corresponds in position to the Kittanning sandstone of Pennsylvania.

"*Split-six*" coal (16).—Separated from the Vanport limestone by a variable thickness of shale is a seam of coal about 4 feet in thickness, but too impure to mine. This is best developed in the southern end of the Georges Creek valley, where it is known as the "Split-six." It does not appear to have any named equivalent in other regions, unless it is the Serubgrass or Upper Clarion coal of Pennsylvania.

*Lower Kittanning coal* (17).—A seam of coal of great persistence, which can be seen at almost every point where strata of this horizon are exposed, occurs at an interval of from 90 to 140 feet above the base and from 170 to 210 feet below the top of the Allegheny formation. This seam corresponds in stratigraphic position to the Lower Kittanning coal of Pennsylvania.

*Middle Kittanning coal* (18).—Another seam of equal persistence is found at a distance of from a few inches to 30 feet above the top of the Lower Kittanning coal. Over broad areas it is so close to the Lower Kittanning that the two form practically one seam. The upper of these closely associated seams is probably the equivalent of the Middle Kittanning coal of Pennsylvania.

The Lower and Upper Kittanning coals are called in the upper Potomac basin the Davis coal, and locally in the lower Georges Creek basin and in the vicinity of Piedmont, West Virginia, by the name of the "Six-foot."

*Upper Kittanning coal* (19).—Separated from the Middle Kittan-

ning coal by from 30 to 60 feet of shale and sandstone is a seam of coal from 1 to  $3\frac{1}{2}$  feet in thickness. This is in the position of the Upper Kittanning coal.

*Lower Freeport sandstone* (20).—A short distance above the Upper Kittanning coal is a massive sandstone of variable thickness, which corresponds in position to the Lower Freeport sandstone.

*Lower Freeport limestone* (21).—A limestone 16 feet in thickness was encountered at a distance of 28 feet above the Upper Kittanning coal in one of the bore-holes at Henry. This is the horizon of the Lower Freeport limestone of Pennsylvania. This limestone has not been seen elsewhere in Maryland.

*Lower Freeport coal* (22).—A seam of coal of variable thickness sometimes appears at a distance of from 35 to 60 feet below the top of the Allegheny formation. It corresponds in position to the Lower Freeport coal of Pennsylvania.

*Upper Freeport or Roaring Creek sandstone* (23).—A short distance above the Lower Freeport coal is a very massive, sometimes conglomeritic, sandstone. This is the Upper Freeport sandstone of Pennsylvania, or the Roaring Creek sandstone of West Virginia, recently described by Dr. I. C. White.<sup>1</sup>

*Upper Freeport limestone and Bolivar fire-clay* (24).—Immediately above the Upper Freeport sandstone, or the horizon of that sandstone, there sometimes appears a thin limestone which corresponds in position with the Upper Freeport limestone. At several places a flint fire-clay has been observed at this horizon, and in such cases the limestone is absent. A similar relationship has been reported from Pennsylvania, where the Bolivar fire-clay is regarded as "replacing" the Lower Freeport limestone.

*Upper Freeport coal* (25).—At the top of the Allegheny formation is a very persistent seam of coal, which, in its relationships to the overlying and underlying strata, corresponds to the Upper Freeport coal of Pennsylvania. This seam has been called the "Four-foot"

<sup>1</sup> W. Va. Geol. Survey, vol. ii, 1903, pp. 462, 463.

in the Georges Creek valley and the "Three-foot" in the Potomac valley. In the Piedmont folio of the U. S. Geological Survey and the "Report on the Geology of Allegany County" it is called the Thomas coal.

#### CONEMAUGH FORMATION.

*Composition and relations.*—The strata here referred to the Conemaugh formation consists of a series of sandstones, shales, conglomerates, limestones, and coal seams. The total thickness varies from 600 to 700 feet. The average thickness in the Georges Creek basin is about 630 feet. In the Potomac basin it is slightly less. In the Castleman basin the only complete measurement obtainable in Maryland gave about 700 feet, which, however, is 100 feet in excess of the thickness obtained by the Pennsylvania survey farther north in the same basin. The thickness in the lower Youghiogheny basin is slightly over 600 feet.

This formation, generally known hitherto under the name of the Lower Barren Coal Measures, or Lower Barren Measures, was called the Conemaugh formation by Franklin Platt in 1875<sup>1</sup> from the typical development of these rocks along the Conemaugh river, in western Pennsylvania. This formation has also been known under the name of the Pittsburg coal series and the Elk river series, while that portion above the Four-foot coal of the Potomac valley was called by the U. S. Geological Survey in its Piedmont folio the Fairfax formation.

*Lower Mahoning sandstone* (26).—A very massive and persistent sandstone from 25 to 50 feet in thickness occurs at the base of the Conemaugh formation. It corresponds to the lower part of the Mahoning sandstone of western Pennsylvania and eastern Ohio.

*Mahoning limestone* (27).—Overlying the Lower Mahoning sandstone is sometimes a bed of limestone corresponding to the Mahoning limestone. It has been recorded by Dr. I. C. White<sup>2</sup> from

<sup>1</sup> 2nd Geol. Survey, Pa., H., p. 8.

<sup>2</sup> U. S. Geol. Survey, Bull. 65, 1891, p. 82.

a bore-hole at Fairfax, W. Va., where it has a thickness of 20 feet, and occurs at a distance of 42 feet above the base of the formation.

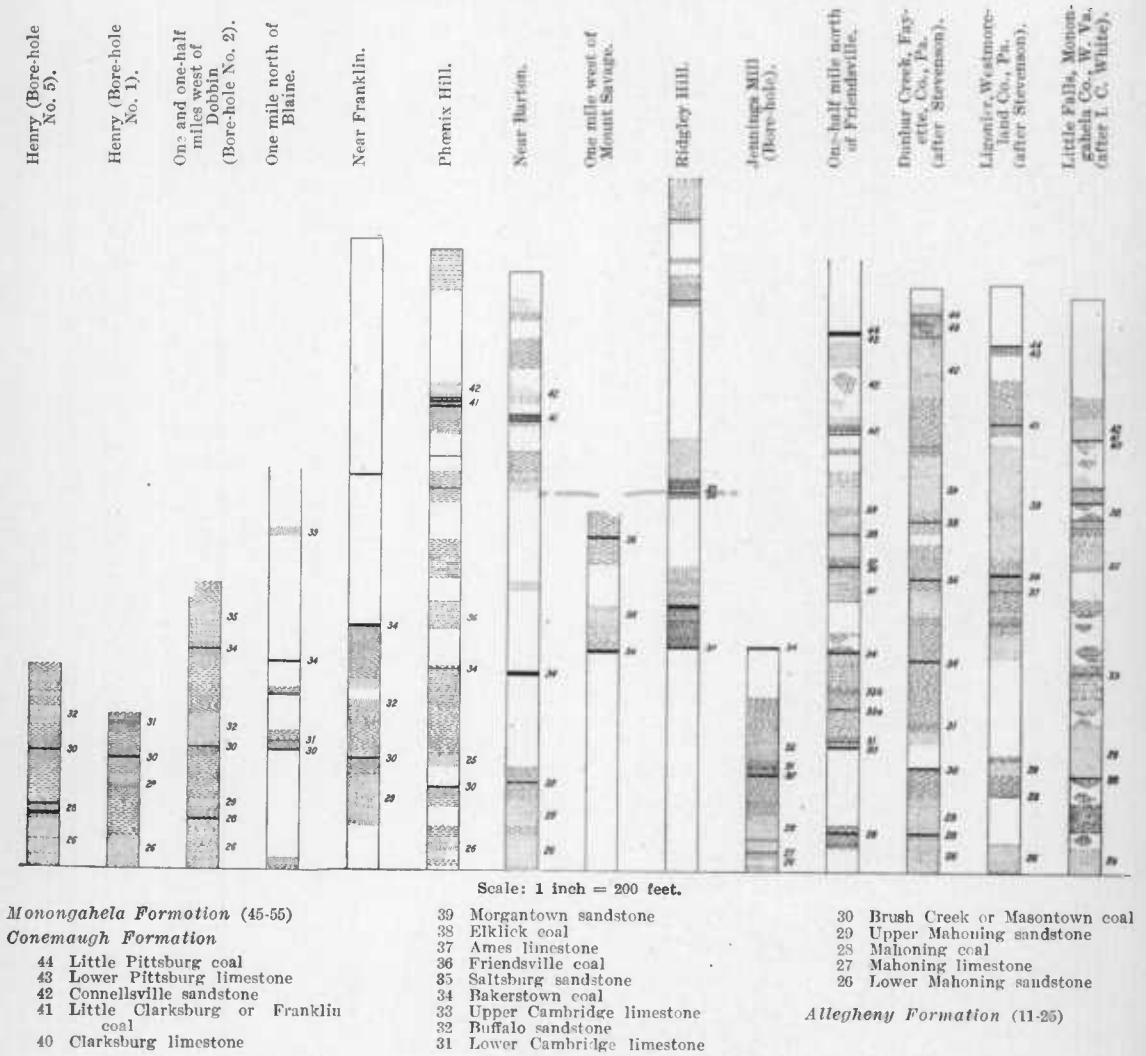

FIG. 23.—Columnar Sections of the Conemaugh Formation.

In the bore-hole at Jennings mill, in the Castleman basin, it is apparently represented by a bed of carbonate of iron three feet in thickness

and is about 20 feet above the base of the formation. This corresponds to the Johnstown iron ore, which, in Pennsylvania, is recognized as occurring at the horizon of the Mahoning limestone.

*Mahoning coal* (28).—In the absence of the Mahoning limestone there frequently appears in its place a thin seam of coal, known in Pennsylvania and West Virginia as the Mahoning coal.

*Upper Mahoning sandstone* (29).—The Upper Mahoning sandstone lies immediately above the black roof shales of the Mahoning coal, or the Mahoning limestone, as the case may be; or, in the absence of both the coal and the limestone, it forms one continuous mass with the Lower Mahoning sandstone. It varies much in lithologic character and thickness. Sometimes it is very massive and conglomeritic, while at other times it is thin-bedded and shaly.

*Brush Creek coal* (30).—A seam of coal having a thickness of from 18 to 24 inches, and without partings, is found in a position varying from 85 to 125 feet above the base of the formation. From its position above the Mahoning sandstone, and more especially from its relation to the overlying fossiliferous beds, this is regarded as the equivalent of the coal formerly called "Masontown" by Dr. I. C. White,<sup>1</sup> although it is not the Masontown coal of the type locality (Masontown, Preston county, West Virginia) which has recently been shown by Dr. I. C. White<sup>2</sup> to belong at the Bakerstown horizon. The coal which actually occurs at the supposed horizon of the Masontown coal was renamed Mason by Dr. I. C. White<sup>3</sup> from the occurrence at Mason, Kanawha County, W. Va. The name Farmington coal was applied by Mr. M. R. Campbell<sup>4</sup> in 1902 from the occurrence of the coal at Farmington, Fayette County, Pennsylvania, and antedates Mason by about a year. The Brush Creek coal of the Pennsylvania Survey belongs at this horizon, and that name, being the oldest, should be used.

<sup>1</sup> U. S. Geol. Survey, Bull. No. 65, 1891, pp. 72-85, 94-95.

<sup>2</sup> W. Va. Geol. Survey, vol. II, 1903, pp. 268, 285.

<sup>3</sup> Loc. cit., p. 285.

<sup>4</sup> Masontown-Uniontown Folio, U. S. Geol. Survey, Geol. Atlas, folio 82, p. 12.

*Lower Cambridge limestone* (31).—Separated from the Brush Creek coal by about five feet of fissile, black carbonaceous shale is a band of calcareous shale or bituminous limestone, usually about eight inches in thickness. This limestone and the overlying shales are filled with well preserved marine fossils. The fauna is very rich, both in individuals and in species. No detailed study has as yet been made of it, but enough species have been determined to make it certain that it is the fauna of the Lower Cambridge limestone of Ohio and Pennsylvania. The greatest thickness of this limestone known in Maryland was obtained in the bore-hole at Jennings mill. Here it is three feet thick, and is overlain by four feet of black, fossiliferous shale.

*Buffalo sandstone* (32).—A short distance above the Lower Cambridge limestone is a sandstone, which sometimes attains a thickness of 40 feet. It corresponds with the Buffalo sandstone of western Pennsylvania, which was formerly considered to be the equivalent of the Upper Mahoning sandstone, but which Dr. I. C. White has shown to overlie the Lower Cambridge limestone.

*Grantsville ("Beachey") coal*.—This seam occurs in the Castleman basin only. Its position is apparently a short distance below the Bakerstown seam, but cannot be exactly determined. It may be a local development of the "Honeycomb" or Bakerstown, or may belong as much as 60 feet below that seam. It is, however, more than eighty feet above the Brush Creek coal. In regard to its correlation it may be said that if it is not a local phase of the Bakerstown it has no equivalent in the other coal basins of Maryland. In the Salisbury basin of Pennsylvania, of which the Castleman basin is the southern continuation, there are three coal seams between the "Bakerstown" and the "Masontown"<sup>1</sup> (Brush Creek) which have no recognized equivalent elsewhere. The "Beachey" seam is probably one of these, but there is no positive evidence as to which it is. It

<sup>1</sup> I. C. White, Bull. U. S. Geol. Survey, No. 65, 1891, p. 76.

was named the Grantsville coal<sup>1</sup> from its typical development near the town of that name.

*Upper Cambridge limestone* (33).—In the river bluff north of Friendsville there are two thin limestone beds at intervals of 32 and 50 feet respectively above the Lower Cambridge limestone. One or both of these probably represent the Upper Cambridge limestone of Ohio. Both beds carry marine fossils.

*Lower red shales*.—The interval between the top of the Buffalo sandstone and the under clay of the Bakerstown coal contains a large amount of red and green shale. The Upper Cambridge limestones occur in these shales, and the red shales themselves carry fossils. These red beds are very persistent, and their outcrop can be easily traced throughout the Lower Youghiogheny basin. They were encountered at their normal position in the bore-hole at Jennings mill, in the Castleman basin, and are evidently the beds known by that name in Pennsylvania.

*Bakerstown coal* (34).—A very persistent seam, which in some districts is of considerable economic importance, occurs at an interval varying from 90 to 135 feet above the Brush Creek coal. The thickness of the coal varies from two to five feet. This seam occupies the stratigraphic position of the Bakerstown coal of Pennsylvania. It is the locally recognized Barton coal, described by that name in the Report on the Geology of Allegany County, but apparently not the Barton coal of the Pennsylvania reports.<sup>2</sup> In the Georges Creek basin it is commonly known as the "Three-foot," in the Potomac valley as the "Four-foot," and in the Castleman valley as the "Honeycomb" seam.

*Saltsburg sandstone* (35).—A massive cross-bedded sandstone, about 30 feet in thickness, occurs above the Bakerstown coal, and is separated from it by a variable thickness of shale. This sandstone is evidently the Saltsburg sandstone of Professor Stevenson,<sup>3</sup> so named from its occurrence at Saltsburg, Pennsylvania.

<sup>1</sup> The Physical Features of Garrett County. Md. Geol. Survey, 1902, p. 136.

<sup>2</sup> 2d Geol. Survey, Pa., KK, 1877, pp. 67, 68.

<sup>3</sup> 2d Geol. Survey, Pa., KKK, 1878, p. 22.

*Maynadier coal.*—This seam which is locally known as the “slate vein,” is apparently confined to the Castleman basin and occurs at an interval of about 40 feet above the Bakerstown coal.

The strata immediately overlying the Bakerstown coal are well exposed in the Castleman valley in the railroad cut one mile south of the National Road. This section is part (Nos. 24 to 34) of the complete Conemaugh section given on page 253. The coal seam 40 feet above the Bakerstown and the limestones underlying it have not been recognized in Maryland outside of this basin, but the coal at least appears to be very constant within the basin. The name Maynadier coal<sup>1</sup> has been given it from its development at the west end of Maynadier Ridge. Neither the coal nor the limestone can be correlated with any members of the Conemaugh hitherto described from other regions. In other basins this interval is generally concealed or only poorly exposed.

*Friendsville coal.*—This seam occurs at an interval of from 90 to 160 feet above the Bakerstown coal. The interval is about 100 feet in the Georges Creek basin, 160 feet in the Castleman basin, and 90 feet in the Lower Youghiogeny basin. This coal is a thin but very persistent and characteristic seam, which has been of the greatest service in correlation. This seam is the same as the one which has been called the “Crinoidal coal” in the Pennsylvania reports and the “Crinoidal coal” or “Coal 8b” in the Ohio reports. It is possible also that the “Platt coal” of the Somerset basin may be the same as the “Crinoidal.” The coal is well exposed and has been mined for local use at several places in the Castleman basin and in the Lower Youghiogeny basin near Friendsville, Garrett county, from which occurrence<sup>2</sup> it received its name,<sup>3</sup> and also at many places in the northern end of the Georges Creek basin, where it attains the

<sup>1</sup> The Physical Features of Garrett County. Md. Geol. Survey, 1902, p. 136.

<sup>2</sup> The Physical Features of Garrett County, loc. cit., p. 136.

<sup>3</sup> It should be noted that this is not the same as the Friendsville (Illinois) coal of Fuller and Ashley (Bull. 213, U. S. Geol. Survey, 1903, pp. 292, 239) and of Fuller and Clapp (U. S. Geol. Survey, folio 105, 1904, p. 8).



thickness of 28 inches, the greatest known in Maryland. One of these old mines near Mount Savage was visited by Lyell in 1842, who described the occurrence of coal, its position and thickness, and gave a list of fossils found in the overlying shales.<sup>1</sup>

*Ames or Crinoidal limestone* (37).—The Friendsville coal is overlain by either a limestone or a calcareous shale full of marine fossils. This limestone occurs in a position exactly similar, with reference to the overlying and underlying strata, to that of the Crinoidal limestone of the Pennsylvania reports, and to the Ames limestone of the Ohio reports. The fauna, as far as known, is the same as that found in this bed in Ohio and Pennsylvania. In both of these states and in West Virginia the limestone is of very great persistence and has been of the greatest service in the correlation and location of the coals.

*Elklick coal* (38).—A very thin and variable coal, which apparently represents the Elklick coal of Pennsylvania and West Virginia, is found at about 35 feet above the Ames limestone.

*Morgantown sandstone* (39).—Immediately above the Elklick coal or its horizon, if the coal is absent, is a very massive and constant sandstone, frequently conglomeritic in part, which corresponds exactly in its stratigraphic relations with the Morgantown sandstone, so called from its typical development at Morgantown, West Virginia.

*Lonaconing coal*.—This coal is typically developed in the Georges Creek valley near the town of Lonaconing from which occurrence it is here given its name. The coal occurs a short distance above the top of the Morgantown sandstone and about 20 feet below the Franklin coal. Its average thickness is about 2 or 2½ feet. The coal has not been recognized outside of this region except in Fairfax Knob near the headwaters of the Potomac river where it is apparently represented by the seam 27 feet above the Elklick coal.<sup>2</sup>

*Clarksburg limestone* (40).—A short distance above the top of the

<sup>1</sup> Travels in North America, with Geological Observations on the United States, Canada, and Nova Scotia.

<sup>2</sup> W. Va. Geol. Survey, vol. ii, 1903, p. 235.

Morgantown sandstone is a limestone from 3 to 9 feet in thickness. This limestone has a rather characteristic appearance and contains abundant fossil fish and Ostracoda. Marine fossils are entirely absent. In its stratigraphic position, its lithologic characteristics, and the general nature of its fauna this limestone corresponds to the Clarksburg limestone, so called from its occurrence at Clarksburg, West Virginia.

*Franklin or Little Clarksburg coal* (41).—A seam of coal which is identical with the Little Clarksburg coal of Dr. I. C. White is found immediately above the Clarksburg limestone. In the Georges Creek basin this coal is popularly called the "Dirty-nine-foot," and in the Report on the Geology of Allegany County is was named the Franklin coal from its occurrence near the town of Franklin.

*Connellsville sandstone* (42).—A short distance above the Franklin coal is a very prominent sandstone of considerable thickness. It is very strongly developed in the Georges Creek and Potomac basins, where it has a very marked influence on the topography. This sandstone is found in the stratigraphic position of the Connellsville sandstone of southwestern Pennsylvania.

*Lower Pittsburg limestone* (43).—Almost immediately above the Connellsville sandstone is a thin limestone containing no fossils except Ostracoda, as far as observed. It has all the characteristic features of and evidently is the Lower Pittsburg limestone.

*Little Pittsburg coal* (44).—Immediately above the last-named limestone and about 90 feet below the top of the formation is a seam of coal from 1 to 3 feet in thickness. Another thin coal frequently occurs 30 or 40 feet above this and 50 or 60 feet below the top of the formation. These are evidently the equivalents of the Little Pittsburg coals, of which there are frequently two, which usually occur in positions corresponding to these.

#### MONONGAHELA FORMATION.

*Composition and relations.*—The strata composing the Monongahela formation in Maryland consist of a series of shales, sandstones,

limestones, and coal seams. The thickness varies from 240 to 270 feet. The formation is entirely restricted in Maryland to the Georges Creek-Potomac basin. The name "Monongahela series" was proposed by H. D. Rogers in 1840<sup>1</sup> for the Upper Coal Measures as exposed in the valley of the Monongahela river. The name has had a varied usage since then, part of the time being employed

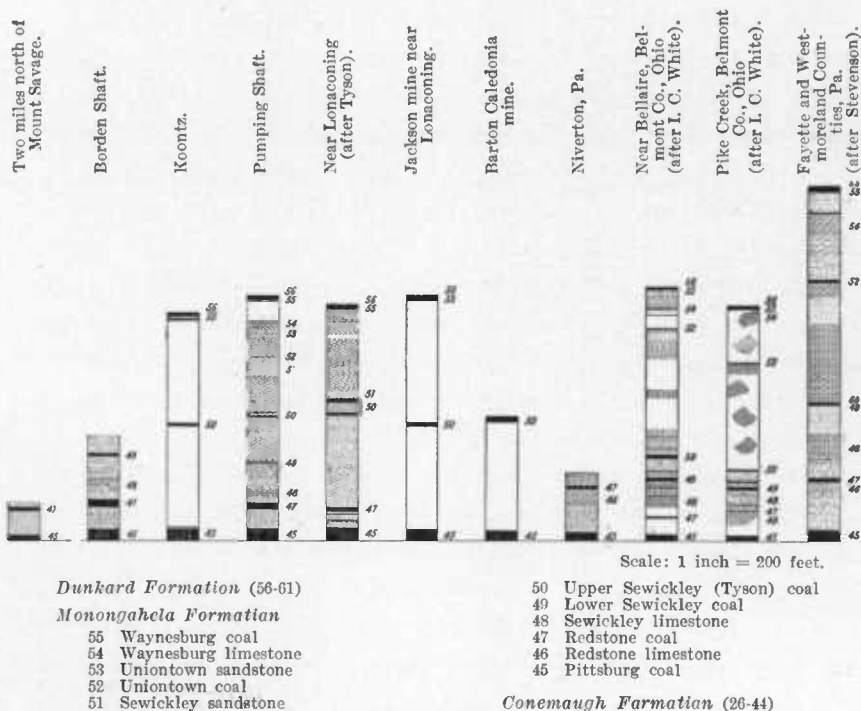

FIG. 24.—Columnar Sections of the Monongahela Formation.

in a broader sense to include the upper half of the Coal Measures. The U. S. Geological Survey in its Piedmont folio has employed the term Elk garden formation for all of the beds exposed in the Potomac basin above the base of the Pittsburg coal.

<sup>1</sup> Fourth Annual Report of the Geological Survey of the State of Pennsylvania, p. 150.

*Pittsburg coal* (45).—At the base of the Monongahela formation is the seam of coal known locally as the “Big vein” or “Fourteen-foot” coal. This seam in its stratigraphic relations to the overlying and underlying beds corresponds exactly to the Pittsburg coal. The fauna of the roof shales, as far as our present knowledge goes, is the same; and Dr. I. C. White<sup>1</sup> has pointed out the identity of structure within the bed.

The various elements composing the seam are constant and characteristic in number and relative position. The relative thickness of these individual elements varies from place to place. From the Pittsburg region toward the southeast there is a gradual increase in the thickness of the “breast” coal, which reaches a maximum in the southern end of the Georges Creek basin, where the entire bed has been found at a single locality to reach 22 feet in thickness. There is greater change within the limits of the Georges Creek basin than there is between the central part of the Georges Creek basin and the Pittsburg region. This change consists chiefly in an increase in the number and thickness of the shales at the expense of the “breast” coal. This seam was called the Pomeroy coal in the Ohio reports and the Elkgarden coal in the Piedmont folio of the U. S. Geological Survey and in the Report on the Geology of Allegany County. The name Pittsburg coal was applied to this seam by J. P. Lesley in 1856.

*Redstone limestone* (46).—A thin limestone is sometimes found a few feet above the Pittsburg coal. In this region it is commonly separated from it by argillaceous shales. It occurs in the position of the Redstone limestone of Pennsylvania.

*Redstone coal* (47).—At an interval of from 18 to 45 feet above the Pittsburg coal is a seam of coal which corresponds in position to the Redstone coal of Pennsylvania. It is apparently very constant in the Georges Creek basin, although it has not been prospected for, and has accordingly not been opened at many points. The thickness is about 4 feet.

<sup>1</sup> The Pittsburg Coal Bed, Amer. Geol., vol. xxi, pp. 49-60.

*Sewickley limestone* (48).—A bed of limestone occurs about 10 feet above the Redstone coal. It is in the stratigraphic position of the Sewickley limestone of Pennsylvania.

*Lower Sewickley coal* (49).—At an interval of from 25 to 30 feet above the Sewickley limestone, and from 40 to 45 feet above the Redstone coal, is a thin seam of coal which has been seen in the Borden shaft and the Pumping shaft and other places in the Georges Creek basin. This seam occurs at the horizon of the Sewickley coal. As there is another seam above this, however, which still falls within the limits of the Sewickley, and as the Sewickley coal, in being traced westward from its type locality by the Pennsylvania geologists, has been found to split into two seams, it is considered probable that the same has taken place to the eastward. This seam is therefore referred to the Lower Sewickley.

*Upper Sewickley or Tyson coal* (50).—A seam of coal of great persistence and considerable economic importance is found at an interval of about 45 feet above the Lower Sewickley, and from 105 to 120 feet above the Pittsburg coal. This seam has long been known in the Georges Creek region as the Tyson or "Gas" coal. As is stated above, this seam falls within the position of the Sewickley coal, and probably corresponds to the upper split of the Sewickley in western Pennsylvania and eastern Ohio.

*Sewickley sandstone* (51).—Separated from the underlying Upper Sewickley coal by a variable thickness of shale is a sandstone whose greatest observed thickness in Maryland is about 15 feet. Dr. I. C. White, in Bulletin No. 65 of the United States Geological Survey, calls attention to the fact that either a limestone or a sandstone, one only, however, to the exclusion of the other, occurs in the interval between the Sewickley and the Uniontown coals. Where sandstone occurs in this interval it is called the Sewickley sandstone. The limestone, on the other hand, has been differentiated into the Uniontown and Benwood or "Great" limestones. Throughout Maryland the limestone is apparently entirely absent. This occurrence therefore confirms the generalization which Doctor White based on his obser-

vations in Pennsylvania, West Virginia, and Ohio, namely, that either the limestone or the sandstone, but never both, are found in the interval between the Sewickley and Uniontown coals.

*Uniontown coal* (52).—A thin coal is found in the Pumping shaft section near Frostburg, about 60 feet above the Upper Sewickley coal and close to the top of the Sewickley sandstone. It corresponds in position and character to the Uniontown coal of Pennsylvania.

*Uniontown sandstone* (53).—A short distance above the Uniontown coal, in the Pumping shaft section, there is a thin sandstone which is probably a poor representation of the Uniontown sandstone.

*Waynesburg limestone* (54).—A limestone occurs a short distance above the Uniontown sandstone and from 20 to 30 feet below the top of the formation which corresponds in its stratigraphic position to the Waynesburg limestone of Pennsylvania and West Virginia.

*Waynesburg coal* (55).—There is a very persistent coal seam, of considerable economic importance, that may occur anywhere in the interval up to 20 feet above the top of the Waynesburg limestone. From its position, 230 to 250 feet above the base of the Monongahela formation, and in its regular stratigraphic sequence, it is regarded as the Waynesburg coal. In the Report on the Geology of Allegany County it was named the Koontz coal, from its occurrence at the mining village of that name near Lonaconing. The identity of this seam with the Waynesburg seam now appears so certain that the name Koontz will be considered as a synonym. The roof of this coal is the top of the Monongahela formation.

#### DUNKARD FORMATION.

*Composition and relations.*—The strata here referred to the Dunkard formation have an extreme thickness of 390 feet in Maryland. It is evident that the entire formation is not represented. The present area of the Dunkard deposits in Maryland is restricted to a few small tracts in the central part of the Georges Creek basin. The surface has so little relief that there are few good exposures, and it is

almost impossible to obtain a detailed section. In consequence the stratigraphic sequence is very imperfectly known.

The Dunkard formation was named by Dr. I. C. White in 1891<sup>1</sup> from Dunkard creek, in southwestern Pennsylvania. The rocks of this formation had previously been known as the "Upper Barren Coal Measures" or "Upper Barren Measures," and they were di-

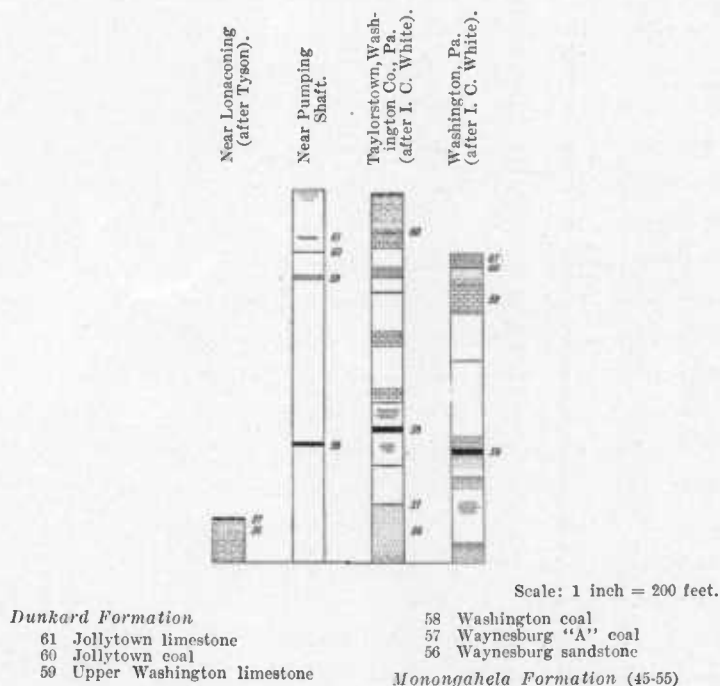

FIG. 25.—Columnar Sections of the Dunkard Formation.

vided into the "Green county group" and the "Washington county group." As will be noted below, the strata in Maryland belong almost exclusively to the latter division, which has been referred to as the Frostburg formation.<sup>2</sup>

<sup>1</sup>Stratigraphy of the Bituminous Coal Fields of Pennsylvania, Ohio, and West Virginia. Bull. No. 65, U. S. Geological Survey, p. 20.

<sup>2</sup>Md. Geol. Survey, vol. 1, 1897, p. 188.

*Waynesburg sandstone* (56).—A sandstone of no very great prominence occurs a short distance above the Waynesburg coal. It probably represents the Waynesburg sandstone, since its stratigraphic position is the same.

*Waynesburg "A" coal* (57).—A thin coal which corresponds in position to the Waynesburg "A" coal of Pennsylvania and West Virginia is found on top of the Waynesburg sandstone, and about 45 feet above the Waynesburg coal.

*Washington coal* (58).—About 75 feet above the Waynesburg "A" coal, and separated from it by an interval consisting in Maryland apparently of shales and limestones, is a seam of coal whose character is not well known. The thickness of this coal is about  $3\frac{1}{2}$  feet and its quality is not known. This coal corresponds in position to the Washington coal of Pennsylvania.

*Upper Washington limestone* (59).—A bed of limestone approximately 4 feet in thickness occurs about 170 feet above the Washington coal, and is separated from it by an interval of unknown rocks, apparently shale with some limestone. It is in about the position of the Upper Washington limestone of Pennsylvania.

This stratum is important, inasmuch as its top is the dividing plane between the two divisions of the Upper Barren Measures or Dunkard formation. Almost all of the Dunkard in Maryland falls in the lower division or Washington county group of Stevenson, while the upper or Green county group of Rogers is represented in Maryland by only the 65 to 90 feet of strata overlying this, and which cover an area of only a few acres.

*Jollytown coal* (60).—A thin seam of coal is found about 25 feet above the outcrop of the Upper Washington limestone. It is apparently in the stratigraphic position of the Jollytown coal of Green county, Pennsylvania.

*Jollytown limestone* (61).—A limestone of apparently no very great thickness is found about 15 feet above the Jollytown coal. It is in the position of the Jollytown limestone of Pennsylvania.

Above this limestone there are no good exposures, and not more



than 50 feet of strata are preserved in Maryland. The highest bed is a sandstone which caps the hill east of Borden shaft.

#### CONCLUSIONS.

The detailed comparisons given in the preceding pages show that the various members of the Coal Measures of Maryland closely resemble those found in Pennsylvania and West Virginia. They clearly demonstrate the fact, if any such demonstration is necessary, that the various beds of the Coal Measures have a wide geographical extent, and that the individual coal beds possess certain marked physical characteristics that can be readily distinguished over wide areas. The similarity of sequence of the various members of the coal series is so striking and the faunal and floral characteristics so marked that the determination of the horizons of the several coal seams can be made with remarkable accuracy. In the lower formations of the Coal Measures it has been possible to establish this identity with the Pennsylvania and West Virginia deposits on the basis of actual continuity of the beds, although this is not possible in the higher members of the series. The sequence of deposits and faunal and floral characteristics are such, however, that very little doubt can exist regarding their equivalency.

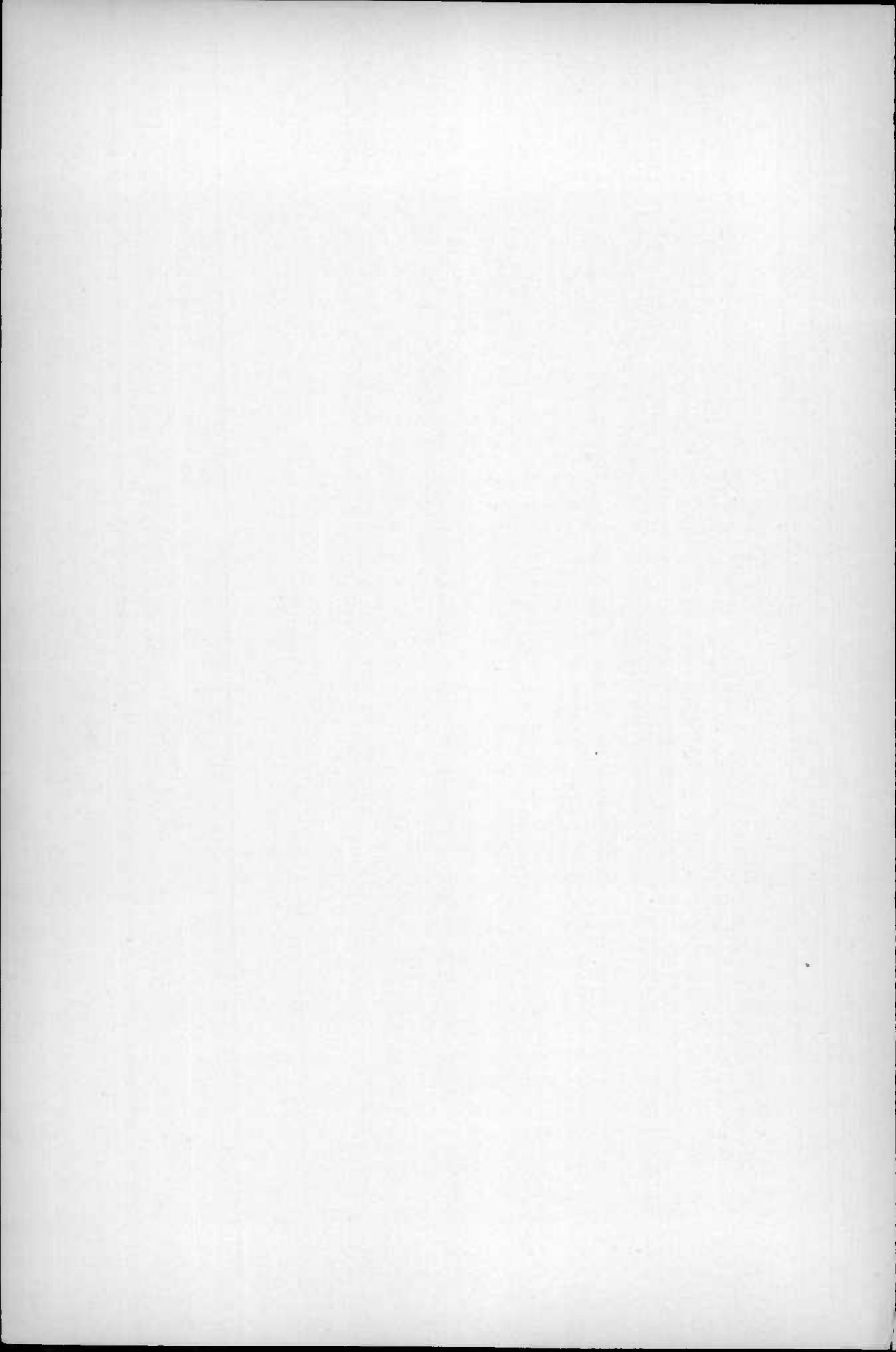

# DISTRIBUTION AND CHARACTER OF THE MARYLAND COAL BEDS

BY

WM. BULLOCK CLARK  
GEO. C. MARTIN AND J. J. RUTLEDGE

---

## GENERAL RELATIONS.

The coal deposits of Maryland are confined to synclines or, as they are called when they contain coal seams, "*coal basins*." There are five of these coal basins in the State. The *Georges Creek basin* lies along the eastern margin of the district between Wills and Savage mountains partly in Allegany and partly in Garrett counties. The *Upper Potomac basin* lies in the southern and southeastern parts of Garrett county, to the east and south of Backbone Mountain. The Potomac river flows near the axis of this basin, so only half of it is within Maryland. This basin is structurally the continuation of the Georges Creek basin. The *Castleman basin* lies in the north-central part of Garrett county, between Meadow and Negro mountains. It is the continuation of the Salisbury basin of Pennsylvania. The *Upper Youghiogheny basin* lies in the west-central part of Garrett county, between Snaggy Mountain and a ridge which is the continuation of Meadow Mountain, parts of which are here called Roman Nose and Halls Hill. The *Lower Youghiogheny basin* lies in the northwest part of Garrett county, to the west of Winding Ridge and to the north of Dog Ridge. It is the continuation of the Confluence basin of Pennsylvania.

A small amount of very impure anthracite coal occurs far to the east of the coal basins, above mentioned, in eastern Allegany county, the best exposures being found in Sidling Hill Mountain where this coal at times reaches several feet in thickness. It is so irregular in thickness and so heavily charged with ash as to have no commercial value. This coal occurs at an horizon older than the Coal Measures

and is confined to the Pocono formation at the base of the Lower Carboniferous. The various prospect openings which have been made in it give no indication of successful development and it will not be further discussed in this report.

Dark carbonaceous shales of Devonian and Silurian age in Washington and Frederick counties have been prospected at various times and much local excitement has arisen over the prospect of the dis-

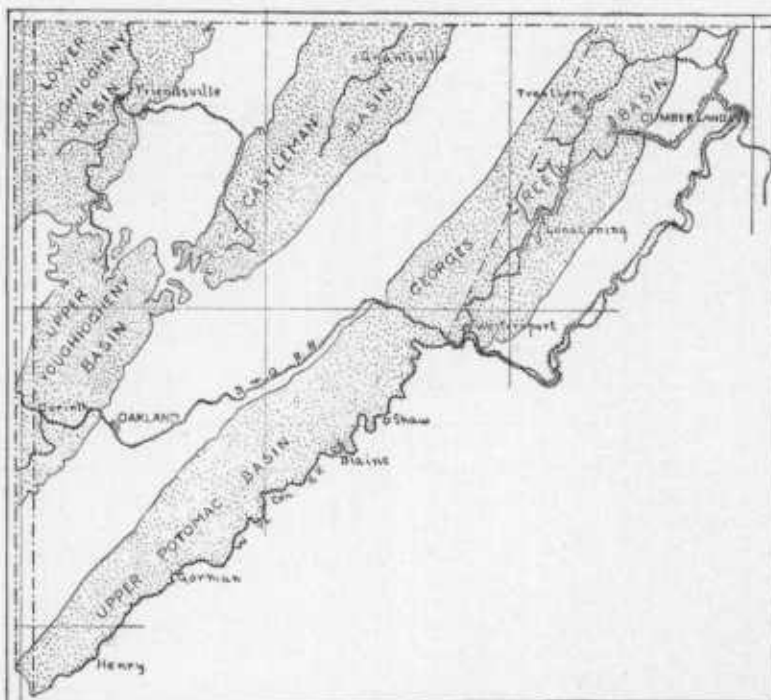

FIG. 26.—Map showing location of Coal Basins in Maryland.

covery of anthracite coal. These black shales, however, contain but a small percentage of carbonaceous matter and search for coal at this horizon cannot but be fruitless. No coal of commercial value has ever been found in rocks of this character.

Occasionally thin seams of coal or lignitic vegetable remains are found in the gray and red sandstones of Triassic age in Carroll, Frederick, and Montgomery counties. There is no probability that these beds will ever yield coal deposits of commercial importance, and hence the few plant beds known in these deposits will not be considered in the present report.

The coal seams which are represented in Maryland are given in their relative positions in the following table. The figures given represent the average thickness of the seam from roof to floor, including coal, bone, slate, etc.

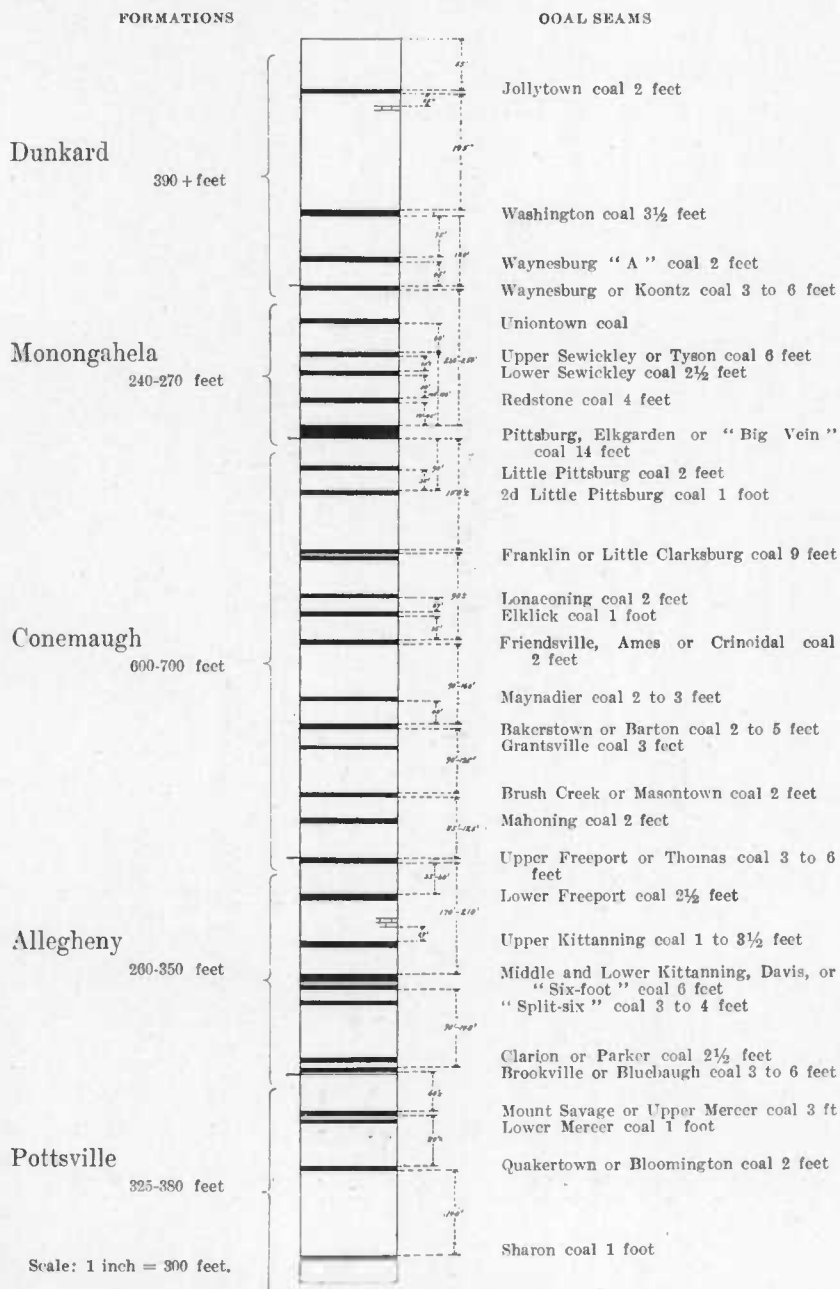

FIG. 27.—Generalized section showing relative position of Coal Seams.

TABLE SHOWING THE CORRELATION OF THE COAL SEAMS.

Local Usage.

Name adopted.	Georges Creek Basin.	Postomac Basin.	Castleman Basin.	Upper Youghiogheny Basin.	Lower Youghiogheny Basin.	Garrett Report (Marlin), 1902. Md. Geol. Survey.	Allegheny Report (O'Hara), 1900. Md. Geol. Survey.	Piedmont Folio (Darton and Tatf.), 1900. U. S. Geol. Survey.	Pennsylvania Survey.	Misc.
Jollytown.....	No local name.	Absent.....	Absent.....	Absent.....	Absent.....	Jollytown.....				
Washington.....	No local name.	Absent.....	Absent.....	Absent.....	Absent.....	Washington.....				
Waynesburg "A".....	No local name.	Absent.....	Absent.....	Absent.....	Absent.....	Waynesburg "A".....				
Waynesburg.....	No local name.	Absent.....	Absent.....	Absent.....	Absent.....	Waynesburg.....	Waynesburg.....			
Uniontown.....	No local name.	Absent.....	Absent.....	Absent.....	Absent.....	Uniontown.....	Uniontown.....			
Upper Sewickley.....	Tyson or Gas.	Absent.....	Absent.....	Absent.....	Absent.....	Upper Sewickley.....	Upper Sewickley.....			
Lower Sewickley.....	No local name.	No local name.	No local name.	Absent.....	Absent.....	Lower Sewickley.....	Lower Sewickley.....			
Redstone.....	Redstone.	No local name.	No local name.	Absent.....	Absent.....	Redstone.....	Redstone.....			
Pittsburg.....	Big Vein or Fourteen-foot.	Fourteen-foot.	Pittsburg.	Absent.....	Absent.....	Pittsburg.....	Elkarden.			
Little Pittsburg.....	Michael's.	No local name.	No local name.	Absent.....	Absent.....	Little Pittsburg.....	Little Pittsburg.....			
Franklin.....	Dirty-nine-foot.	Dirty-nine-foot.	No local name.	Absent.....	Absent.....	Franklin.....	Franklin or Little Clarksburg.....			
Lonsaoning.....	No local name.	No local name.	No local name.	Absent.....	Absent.....	Elklick.....	Elklick or Barton.....			
Elklick.....	No local name.	No local name.	Fossil.....	Absent.....	Absent.....	Friendsville.....	Crimoidal or Platty.....			
Friendsville.....	No local name.	Twenty-two inch.	Absent.....	Absent.....	Absent.....	Friendsville.....	Friendsville.....			
Maynadler.....	Not seen.	Not seen.	Slate Seam.	Absent.....	Absent.....	Maynadler.....	Maynadler.....			
Bakerstown.....	Four-foot or Three-foot.	Four-foot or Three-foot.	Honrycumb.....	No local name.	No local name.	Bakerstown.....	Bakerstown.....			
Grantsville.....	Not seen.	Not seen.	Baucheys.....	Not seen.	Not seen.	Grantsville.....	Grantsville.....			
Brush Creek.....	No local name.	No local name.	No local name.	Not seen.	Not seen.	Masonstown.....	Masonstown.....			
Mahoning.....	No local name.	No local name.	No local name.	No local name.	No local name.	Mahoning.....	Mahoning.....			
Upper Freeport.....	Elk Vein, Three-foot or Four-foot.	Three-foot or Four-foot.	No local name.	No local name.	No local name.	Upper Freeport.....	Upper Freeport or Seam E.....			
Lower Freeport.....	No local name.	No local name.	No local name.	Not seen.	Not seen.	Lower Freeport.....	Lower Freeport or Seam D.....			
Upper Kittanning.....	No local name.	No local name.	No local name.	Not seen.	Not seen.	Upper Kittanning.....	Upper Kittanning or Seam C.....			
Middle and Lower Kittanning.....	Six-foot.	Six-foot or Five-foot.	Bender.....	Corinth or Four-foot.	White Rock or Four-foot.	Middle and Lower Kittanning.....	Middle and Lower Kittanning or Seams C and H.....			
"Split-six".....	"Split-six".....	No local name.	Not seen.	No local name.	No local name.	"Split-six".....	"Split six".....			
Clarion.....	Railroad Seam.	Railroad Seam (in part).	No local name.	No local name.	No local name.	Clarion.....	Clarion or Seam A.....			
Brookville.....	Bluebaugh.....	Bluebaugh.....	No local name.	Not seen.	Not seen.	Brookville.....	Brookville or Seam A.....			
Mount Savage.....	Mount Savage (in part).	Mount Savage (in part).	No local name.	No local name.	No local name.	Mount Savage.....	Mount Savage or Mount Savage.....			
Quakertown.....	No local name.	No local name.	Not seen.	No local name.	No local name.	Quakertown.....	Quakertown.....			
Sharon.....	No local name.	No local name.	Not seen.	No local name.	No local name.	Sharon.....	Sharon.....			

1 Possibly "Scrubsgrass" of Pa. reports.  
 2 "Meigs Creek," Ohio Geol. Survey, vol. vii, p. 298.  
 3 "Pomeroy," Ohio Geol. Survey, vol. vii, p. 287.  
 4 "Little Clarksburg," U. S. G. S. Bull. No. 45, p. 88.  
 5 "Hager," U. S. G. S. Folio No. 82, 1902.  
 6 "Farmington," U. S. G. S. Folio No. 82, 1902.

NOTE.—The coal seams, like the geological formations, are named from the localities where they are typically developed. It is an accepted rule that a seam must ultimately be called by the oldest geographical name applied to it in print. Before the coal seams of Maryland were definitely known to be the continuation of the seams which had been described and named in Pennsylvania and West Virginia and Ohio, local names were applied to them in the publications of this and other organizations. These were intended at the time only as provisional names, which would be abandoned if found to be synonymous with older names, or permanently retained for such seams as had not hitherto been named. Most of the seams in Garrett County have proved to be identical with seams which had been previously named in other regions, so the temporary, local names for them have been abandoned and the older names used. The grounds for this correlation are given in an article by Clark and Martin in the Bulletin of the Geological Society of America for 1902. Most of the seams have also been popularly known by several names which are not geographical and have not been used in print. There is usually a distinct name for each region where the seam is mined. The relation of all the local names used in Maryland to the accepted names used in other regions and to those here adopted is shown in the table above.

#### THE GEORGES CREEK BASIN.

The Georges Creek basin is a deep, broad syncline containing the most complete sequence of the Coal Measures in Maryland. It lies between the Dans-Little Allegheny mountain belt on the east and Big Savage Mountain on the west and extends across the State from the Maryland-Pennsylvania line southwest to the Potomac river. Its length is approximately 20 miles and its average breadth is about 5 miles. The northern end of the district lies in Allegany county but southward the Allegheny-Garrett county line gradually encroaches upon the basin until at the Potomac river the boundary line lies less than a mile west of the central axis of the syncline. The prominent transverse ridge on which Frostburg stands connects the highest slopes of Dans and Big Savage mountains, dividing the valley into two unequal parts and thus determining two districts and unequal areas of drainage. The smaller area lying to the north of Franklin is drained by Jennings Run and Braddocks Run while the southern portion which includes about three-quarters of the entire coal basin is drained by Georges Creek.

The various formations of the Coal Measures in the Georges Creek

basin have been extensively eroded by the various streams, the upper formations naturally having suffered much more extensively than the lower. This has resulted, in the case of the former, in producing numerous isolated areas that project above the general valley levels. In this way outcrops of the higher coal seams occur not only along the side of the syncline but also in the main stream valleys and as the streams descend from higher to lower levels these outcrops continually rise higher and higher above the stream beds, necessitating the use of steep gravity planes in the southern part of the basin in order to transfer the coal from the mine opening on the hillsides to the railroads in the valleys below. Only in the extreme southern and northern portions of the basin have the lower formations been seriously affected by valley-cutting.

The Pittsburg seam, or "Big Vein," from its position in the upper part of the Coal Measures, at the base of the Monongahela formation, has suffered greatly from the extensive erosion of the valley and, except in the central part of the basin where it covers a large continuous tract, is only found in rounded areas well above the main valleys. On that account the greater portion of the "Big Vein" coal is found in Allegany county. The Conemaugh and Allegheny coals which underlie the Pittsburg coal are so overshadowed in importance by it that much less is known regarding them. Within the last few years, however, considerable prospecting has been undertaken with the object of discovering fully the amount and character of these deposits. A number of mines have been successfully opened in these lower beds as well as in some of the seams above the "Big Vein" although these upper beds have smaller and smaller areas in ascending the series of formations. The Conemaugh and Allegheny coals, however, cover much greater areas than the "Big Vein" and when the latter is exhausted the Bakerstown, Upper Freeport, and Lower Kittanning seams will unquestionably supply an important industry.

The character of the country is such that the Monongahela and Conemaugh coals can, for the most part, be worked by drifting and the same is true of the Allegheny coals in the southern end of the



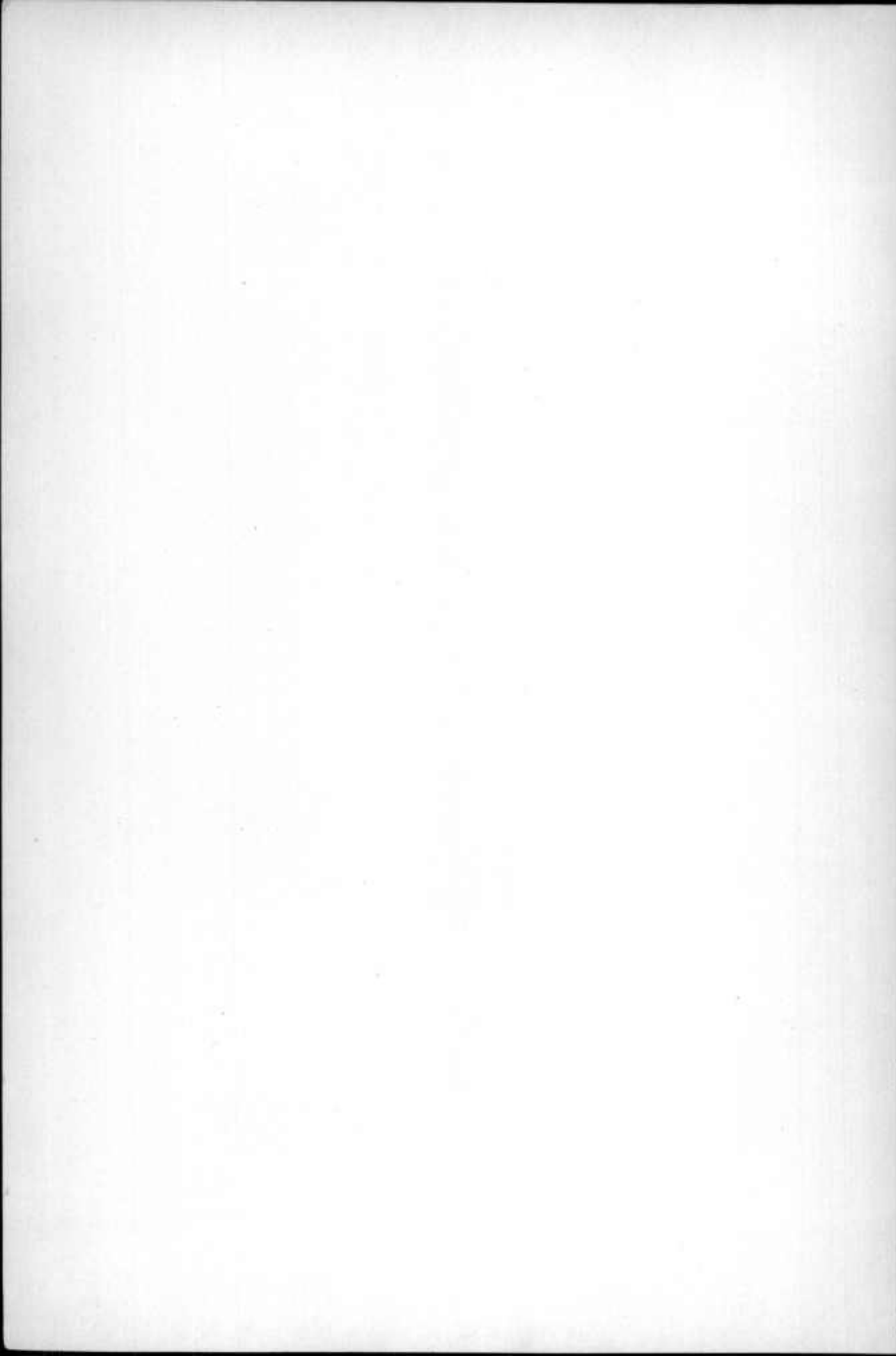

FIG. 1.—FROSTBURG.



FIG. 2.—LONACONING.

VIEWS OF MARYLAND MINING TOWNS.



Georges Creek valley, as well as on many of its lower tributaries, and also along the channel of the Savage river. In the region north of Barton, however, they have been mined only by shafts near the center of the basin or by slopes from the western outcrop.

THE POTTSVILLE COALS OF THE GEORGES CREEK BASIN.

The Pottsville coal seams are of far less importance in Maryland than farther south in Virginia and West Virginia where they include the important Pocohontas and New River coals. These coals have been but little developed anywhere in Maryland although three seams are known to occur in the Georges Creek basin. These coals are thin and under present conditions have little or no commercial value.

*Sharon coal.*—This seam has the largest areal extent of any of the Georges Creek coal. It occurs only a few feet above the base of the formation and is very persistent in its position. It is divided into two beds by several feet of shale and shaly limestone, these beds being referred to in the following sections as the Lower Sharon coal and the Upper Sharon coal. The seams where exposed are too thin and poor to have any commercial value and it is probable they will not be found to be workable at any point in the Georges Creek valley.

*Sections of Lower Sharon Coal.*

NORTH BRANCH POTOMAC RIVER ON COUNTY ROAD ABOVE W. VA. C. R. R., ABOUT ONE MILE BELOW WESTERNPORT.



OUTCROP ON B. & O. R. R. AT SIXTH TELEGRAPH POLE BELOW PIEDMONT GROCERY Co., PIEDMONT, W. VA.





<sup>1</sup> The sections of each coal seam are considered geographically from north to south in each basin. The drawings are on the scale of 1 inch = 2 feet.

*Sections of Upper Sharon Coal.*

COUNTY ROAD, NEAR W. VA. C. R. R., ONE MILE BELOW WESTERNPORT.

Coal		2 in.
Sulphur		1/8 in.
Coal		3 in.
Sulphur		1/2 in.
Coal		2 in.

OUTCROP ON B. &amp; O. R. R., AT SECOND TELEGRAPH POLE BELOW PIEDMONT GROCERY Co., PIEDMONT, W. VA.

Coal		4 in.
Shale		2 in.
Coal		1 ft. 10 in.

*Quakertown coal.*—The Quakertown coal occurs at about 140 feet above the Sharon coal. It has only been found in the lower part of the Georges Creek basin in the valley of the North Branch of the Potomac river where it outcrops a short distance below Westernport. This seam includes in part what has been locally called the Railroad seam, this latter coal being properly referred to several different coal beds, chiefly the Mount Savage and Clarion seams which will be later described. The Bloomington coal of the Allegany county report is also in part synonymous with the Quakertown coal. The Quakertown coal in the lower Georges Creek valley is very thin and will not probably be found to have any commercial value.

*Mount Savage or Upper Mercer coal.*—This seam occurs from 120 to 150 feet above the Quakertown and from 25 to 75 feet below the top of the Pottsville formation. This seam varies so much both in thickness and quality within short distances that it is doubtful whether it can ever be profitably mined except possibly in connection with the fire-clay which is usually associated with it. The Mount Savage coal commonly contains 2 to 3 feet of coal but generally has a thick parting of shale near the middle of the seam. Although the quality is very variable and the lower bench often carries more or

less sulphur yet it is the most promising of the Pottsville coals. It has sometimes been referred to as the "Two-foot vein" in the Georges Creek valley. It is referred to under the name of the Westernport coal in the Allegany County Report. This coal contains

*Section of Quakertown Coal.*

SMALL SHAFT NEAR OLD PHOENIX PLANE, ONE-HALF MILE BELOW WESTERNPORT.

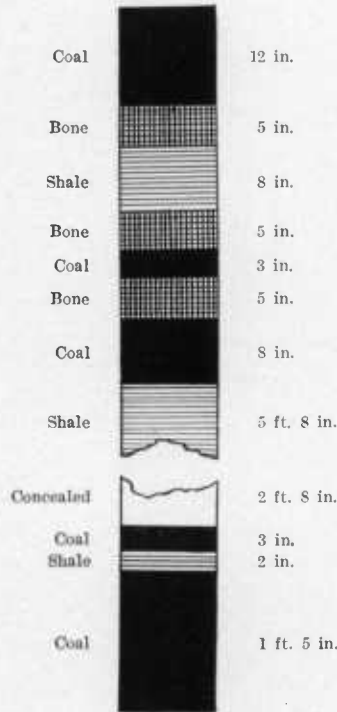

part of what is called locally the "Railroad" seam and is evidently the equivalent of the Upper Mercer coal of Pennsylvania. The Lower Mercer coal is very poorly developed in Maryland, being apparently represented by a thin seam a few feet above the Upper Conoquenessing sandstone. At times it is apparently absent altogether and from its insignificant development is not further discussed in this chapter. The Lower and Upper Mercer coals are separated by the well-known Mount Savage fire-clay.

*Sections of Mount Savage Coal.*

UNION MINING COMPANY'S NEW TUNNEL, TWO MILES NORTHWEST OF MOUNT SAVAGE.

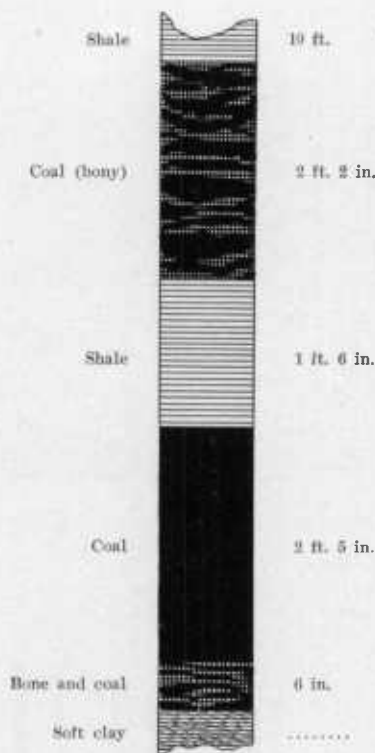

THE ALLEGHENY COALS OF THE GEORGES CREEK BASIN.

The Allegheny coals are of far greater importance than the Pottsville coals. They embrace a number of seams all of which, at least locally, may be considered to have an economic value while two of them will probably be found with further development to occur in commercial quantities throughout much of the Georges Creek basin although too deep in the central and northern part of the area for profitable development at the present time. The Allegheny coals have been very successfully mined in certain areas in Pennsylvania and West Virginia and some attempt has been already made to de-

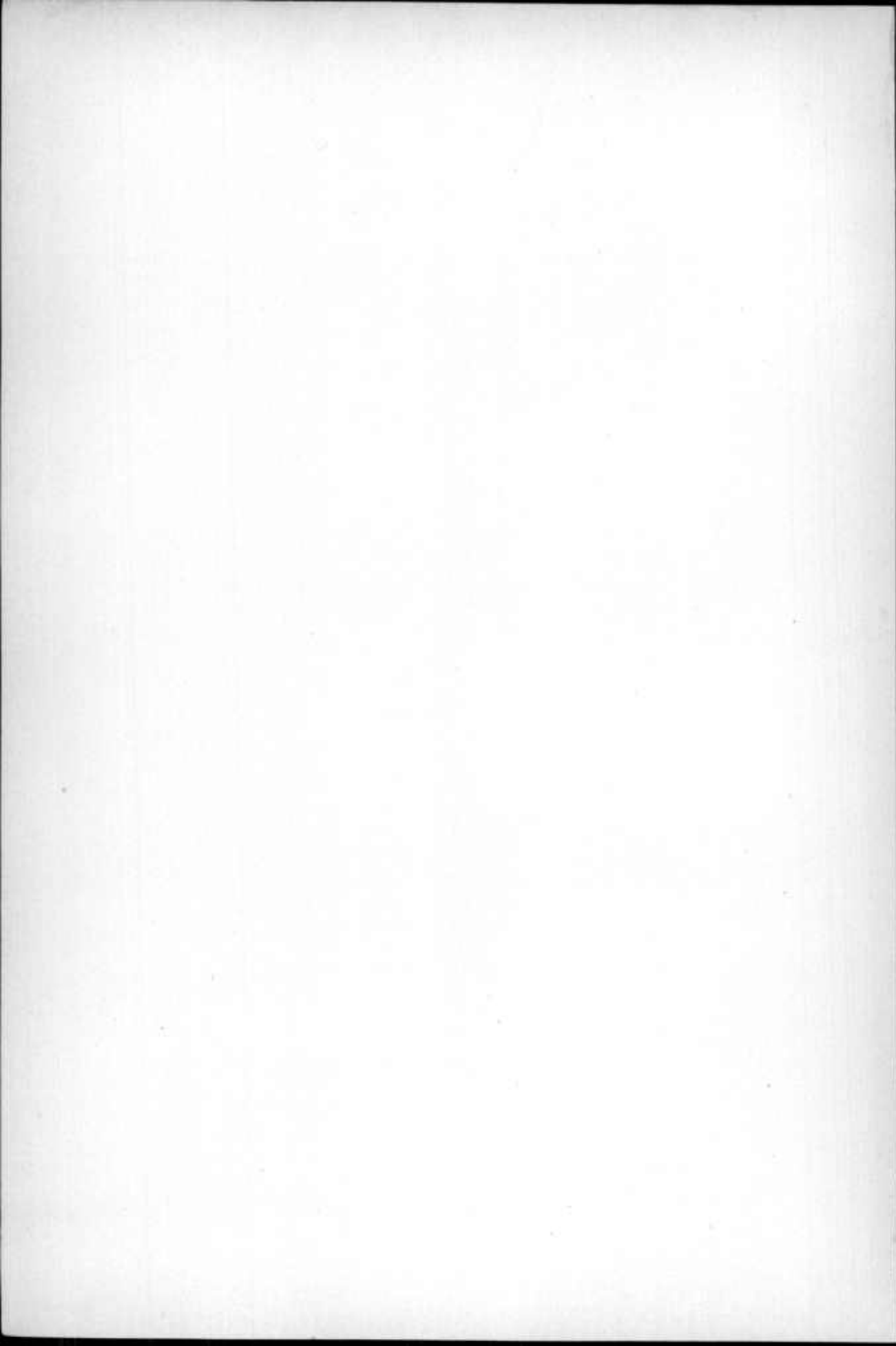

FIG. 1.—CONSOLIDATION COAL COMPANY, OCEAN NO. 1.



FIG. 2.—CONSOLIDATION COAL COMPANY, PUMPING SHAFT.

VIEWS OF COAL MINING PLANTS.





FIRE-CLAY MINE OF SAVAGE MOUNTAIN FIRE BRICK WORKS, ONE AND ONE-HALF MILES NORTHWEST OF FROSTBURG.

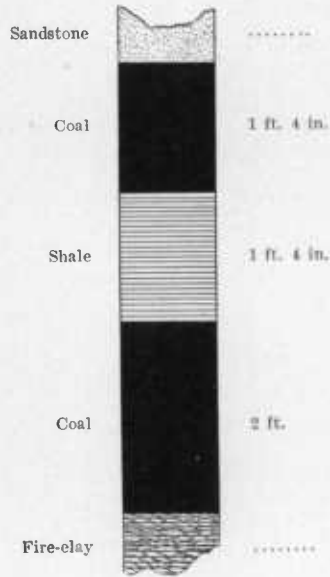

CUT ON B. & O. R. R., OPPOSITE LUKE.

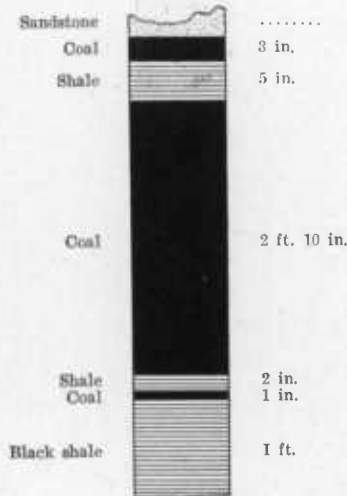

velop them in Maryland, especially in the lower portion of the Georges Creek valley. The Allegheny coals have a very much larger areal extent than the later seams and will unquestionably in the future afford the larger part of the Maryland coal output after the exhaustion of the "Big Vein." These Allegheny coals in the Georges Creek basin are not as thick as in the upper part of the Potomac basin, in southwestern Garrett county, nor are they as readily accessible on account of the thicker cover of later formations over much of the region.

*Brookville (Bluebaugh) coal.*—The Brookville seam is found very near the base of the Allegheny formation. It is very variable in

*Sections of Brookville Coal.*

SHAFT ON TRAMWAY, NEAR BARRELVILLE.

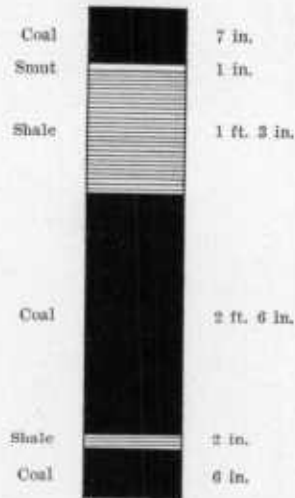

thickness, being best developed around the northern rim of the Georges Creek basin. It generally contains bands of shale and some bone coal. Throughout much of the northeastern portion of the Georges Creek valley it will probably be found to have important economic value. It is not yet known how far it extends beneath the

ABANDONED OPENING OF FAIRWEATHER AND LADUE, MILLSTONE HOLLOW, ONE-HALF MILE SOUTH OF BARRELLVILLE.

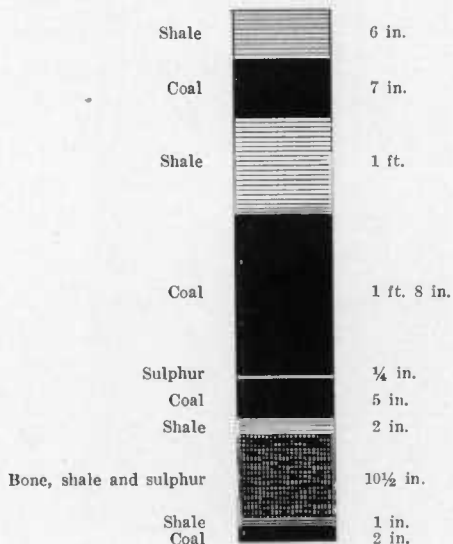

WINTER OPENING ON PINEY MOUNTAIN, TWO MILES EAST OF ECKHART MINES.

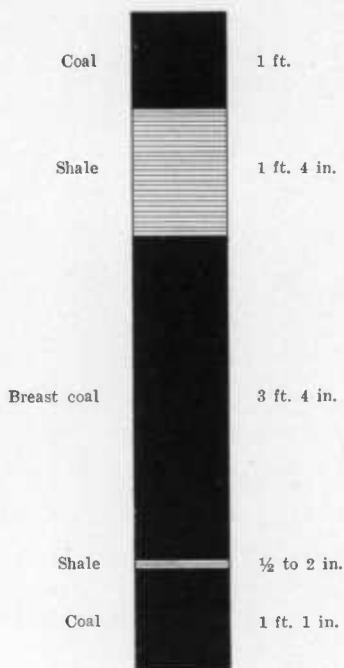

MONTELL TUNNEL, NEAR LOARVILLE.

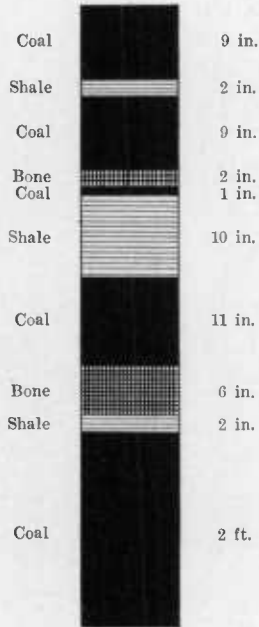

WEST BANK OF WARRIOR RUN, ONE MILE SOUTHEAST OF LOARVILLE.

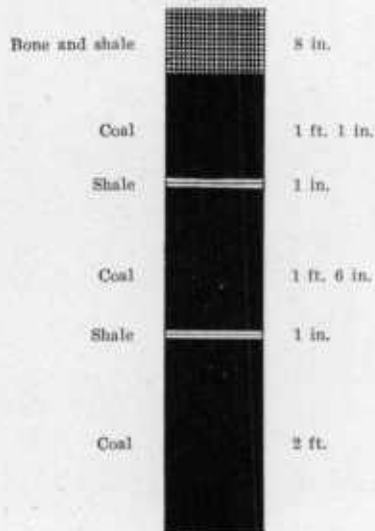



FIG. 1.—CONSOLIDATION COAL COMPANY, OCEAN NO. 3.



FIG. 2.—CONSOLIDATION COAL COMPANY, OCEAN NO. 7.

VIEWS OF COAL MINING PLANTS.

P330B

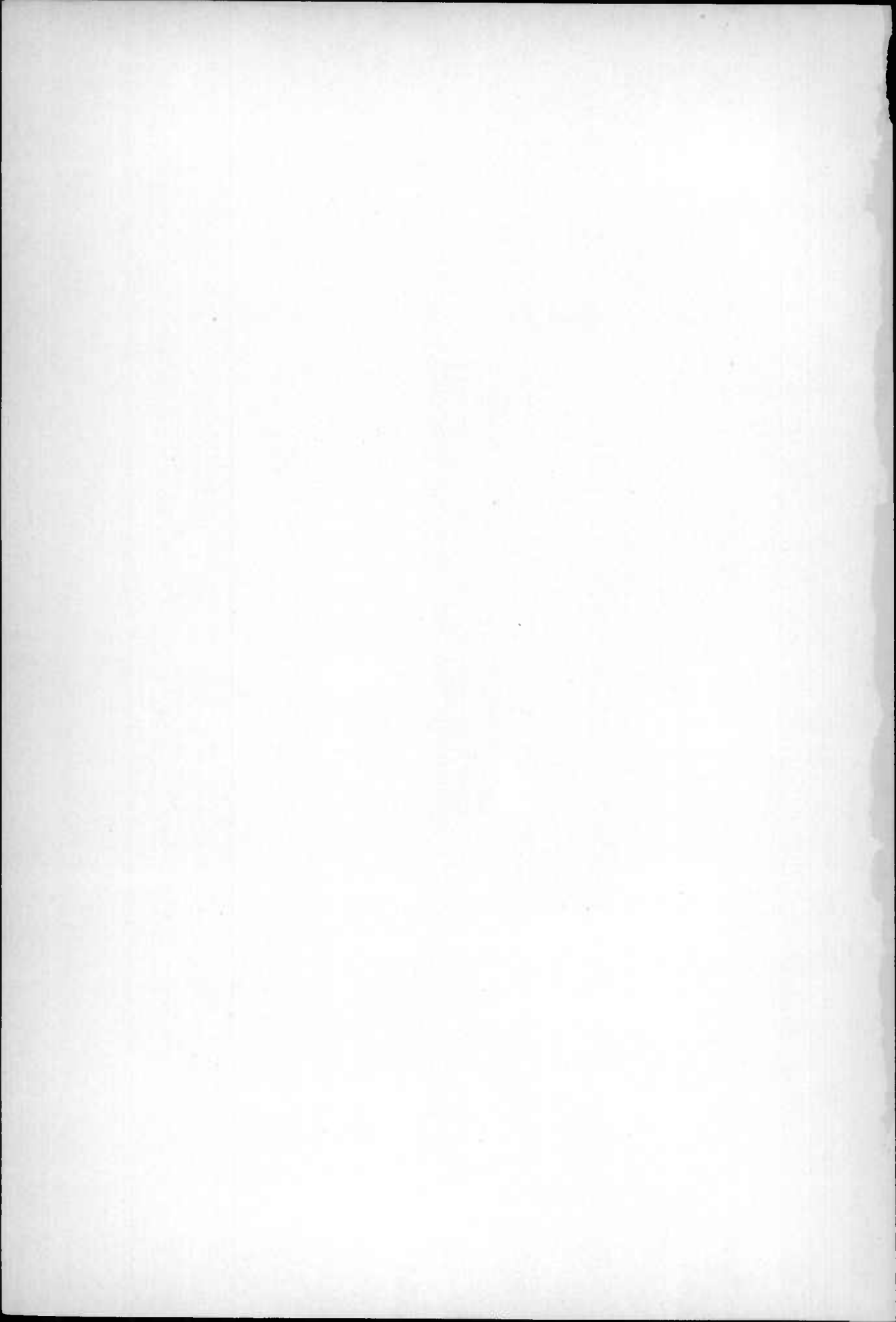

upper coal toward the central part of the basin. This seam has been locally known in the Georges Creek basin by the name of the Bluebaugh coal.

LOWEST SEAM UPON EAST SIDE OF DANS MOUNTAIN, OPPOSITE "BLUEBAUGH" SEAM OPENING, ONE MILE SOUTHEAST OF LOARVILLE.

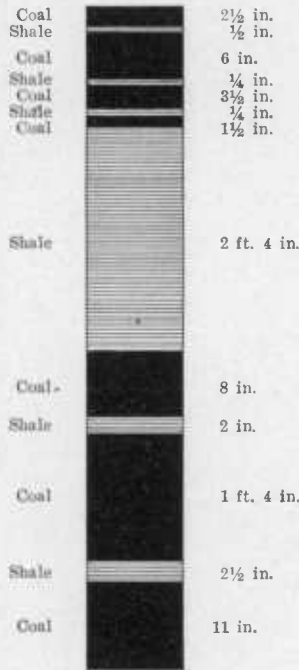

*Clarion (Parker) coal.*—The Clarion coal is found at from 12 to 30 feet above the Brookville coal and like the latter seam is found mainly developed in the northern part of the Georges Creek basin. It is variable in thickness but commonly contains about two feet of coal, but may thicken locally to four feet or more when it is generally broken up by shale partings. The Clarion seam has been often confused with the Mount Savage but can be readily distinguished from the latter by being associated with iron ore rather than with fire-clay even when its stratigraphic position is not clear. The Clarion coal

represents a part of what has been hitherto known as the "Railroad" seam. In the northern Georges Creek basin it has also been locally known under the name of the Parker seam.

*Sections of Clarion Coal.*

CUMBERLAND BASIN COAL COMPANY, ONE-HALF MILE NORTHEAST OF BARRELLVILLE.

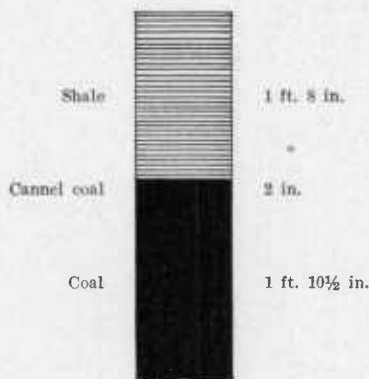

J. O. J. GREENE'S FIRE-COAL MINE, NEAR WESTERNPORT.

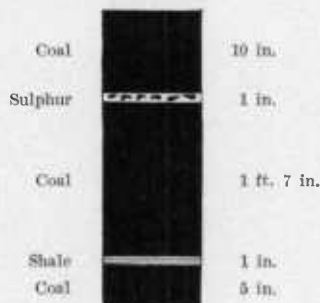

DAVIS COAL AND COKE COMPANY, W. VA. C. R. R., ONE-FOURTH MILE BELOW WESTERNPORT.

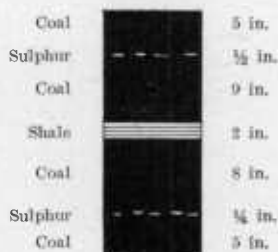



“*Split-six*” coal.—A very variable and impure coal which has locally been referred to as the “Split-six” coal occurs about 30 to 46

*Sections of “Split-six” Coal.*

FIRE-COAL OPENING UNDER OLD GORMAN TIPPLE, FRANKLIN.

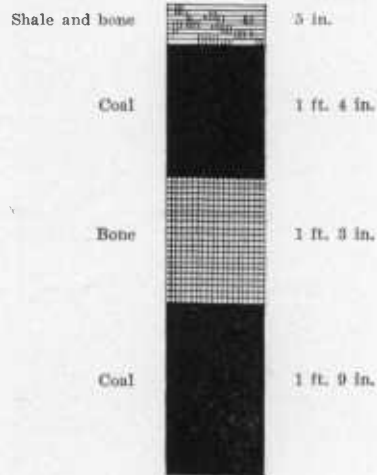

PIEDMONT AND GEORGES CREEK COAL COMPANY, ONE-HALF MILE SOUTH OF FRANKLIN.

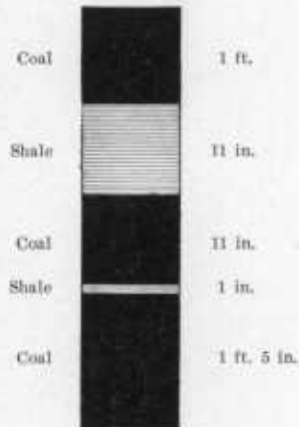

feet below the Lower Kittanning seam and about 30 feet above the Clarion coal. It is best developed in the lower part of the Georges

Creek basin but it is everywhere too impure to mine. It does not appear to have any named equivalent in other areas.

*Lower (and Middle) Kittanning (Davis or "Six-foot") coal.*— This coal forms one of the most persistent seams in the State and has

*Sections of Lower Kittanning Coal.*

COAL PROSPECT NORTHEAST OF SAVAGE MOUNTAIN FIRE-CLAY MINE, TWO MILES NORTHWEST OF FROSTBURG.

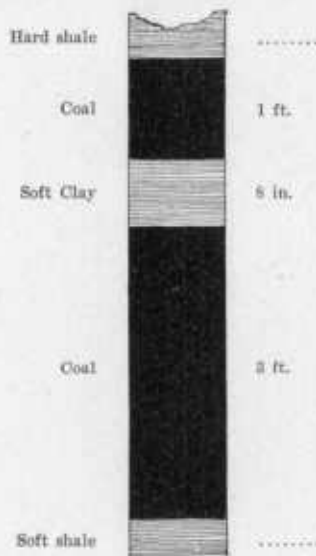

been mined to some extent in the lower Georges Creek valley where it is locally known under the name of the "Six-foot" coal. Over wide areas this coal is separated into two parts by a thin band of shale which may at times increase to several feet in thickness, separating the coal into two different seams. It seems probable that the "Six-foot" coal must, therefore, be regarded as the equivalent both of the Lower and Middle Kittanning of Pennsylvania. This seam occurs from 90 to 150 feet above the base of the formation and from 170 to 210 feet below the top. This seam covers a far greater area than any of the later coals and also maintains its thickness and

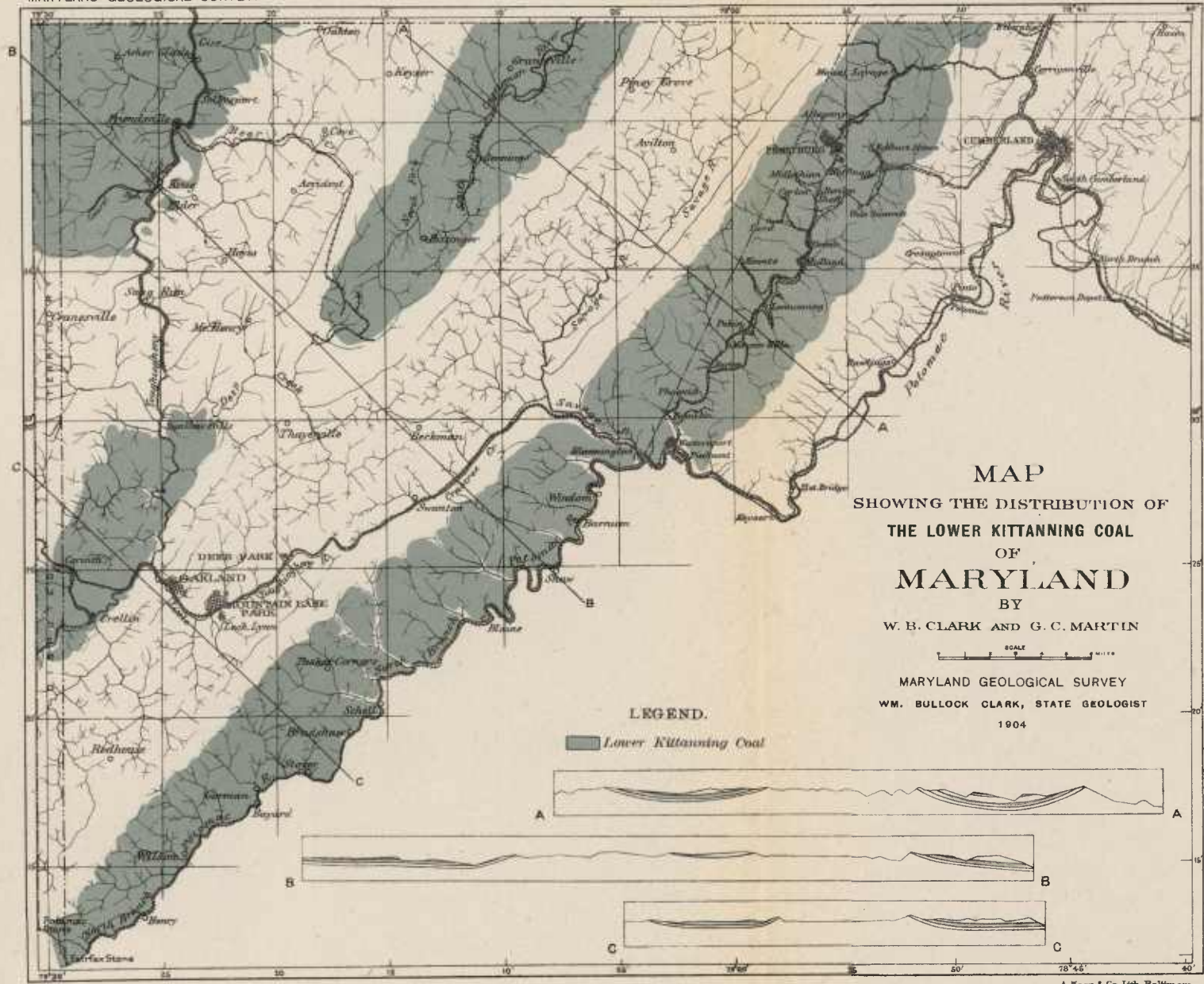

MAP  
 SHOWING THE DISTRIBUTION OF  
 THE LOWER KITTANNING COAL  
 OF  
 MARYLAND

BY  
 W. B. CLARK AND G. C. MARTIN

MARYLAND GEOLOGICAL SURVEY  
 WM. BULLOCK CLARK, STATE GEOLOGIST  
 1904

LEGEND.  
 Lower Kittanning Coal

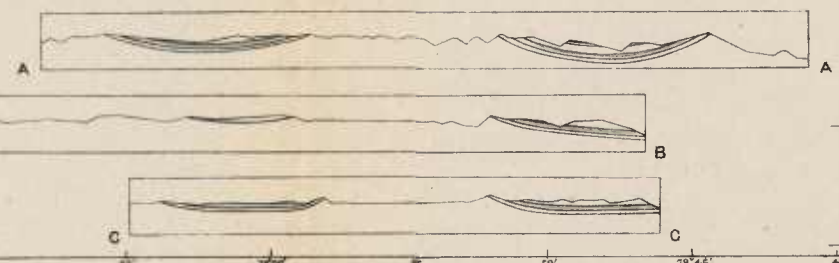

A. Hoen & Co. Lith. Baltimore.

7,334 B.

character over wide areas. It is probably the most valuable coal next to the "Big Vein." At times the shale and bone partings thicken, increasing the expense of working to such an extent that the coal sometimes locally has little commercial value. At times the coal has been squeezed, producing what miners have called "faults" although they are not true faults in the sense in which the name is generally used since the shale partings within the same are never cut off by the

OPENING THREE HUNDRED FEET FROM CAR LINE IN GAP, ONE MILE EAST OF CLARYSVILLE.

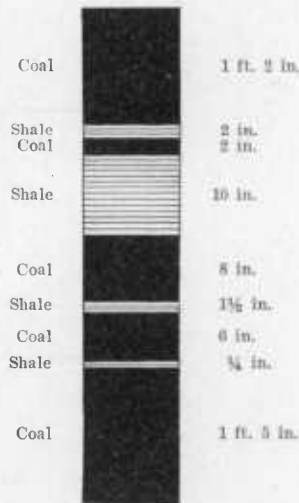

movement although the coal on one or both sides of the middle shale may be squeezed out entirely. This seam has suffered far more extensively in this respect than any of the succeeding coals. The effect of this "faulting" has been to interfere seriously with mining operations although persistence in the development has shown that the coal again reappears along the bedding and may offer a wide area without further disturbance. It is probable that this coal will be extensively mined in the near future. The "Six-foot" seam is the same as the Davis seam of the upper Potomac valley.

PROSPECT NEAR MOUTH OF BRANT'S RUN, ONE AND ONE-FOURTH MILES NORTH-EAST OF CLARYSVILLE.

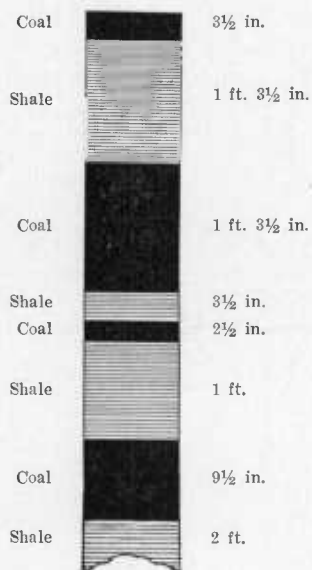

BUSKIRK FARM, ELKLICK RUN, ONE AND ONE-HALF MILES SOUTHEAST OF GILMORE.

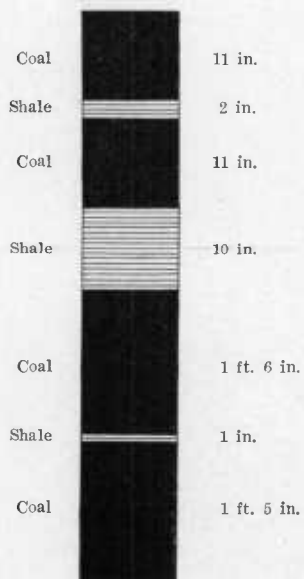

CUMBERLAND-GEORGES CREEK COAL COMPANY. M. GANNON'S PROSPECT  
OPENING, FRANKLIN.

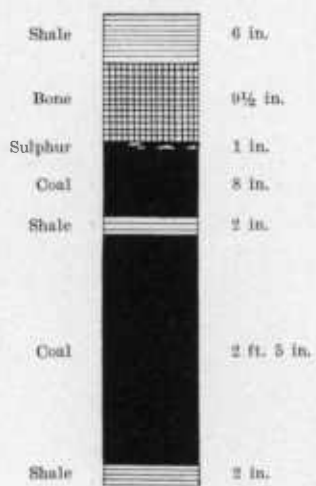

OPENING OF PIEDMONT-CUMBERLAND COAL COMPANY, AT FRANKLIN.

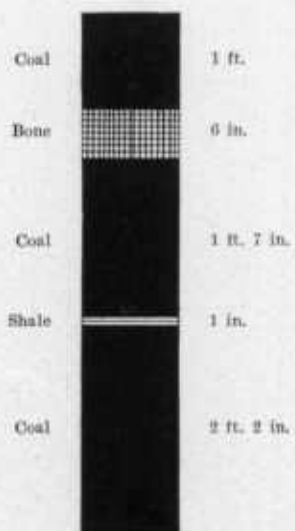

OPENING OF GEORGES CREEK COAL AND IRON COMPANY, THREE MILES WEST OF  
BLOOMINGTON.

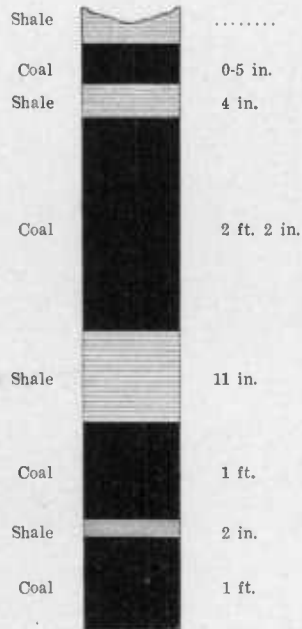

OPENING OF PIEDMONT AND GEORGES CREEK COAL COMPANY, FRANKLIN.

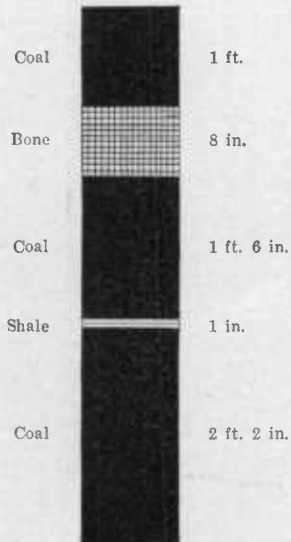





FIG. 1.—UNION MINING COMPANY, UNION NO. 1.



FIG. 2.—BARTON AND GEORGES CREEK VALLEY COAL COMPANY, CARLOS.

VIEWS OF COAL MINING PLANTS.



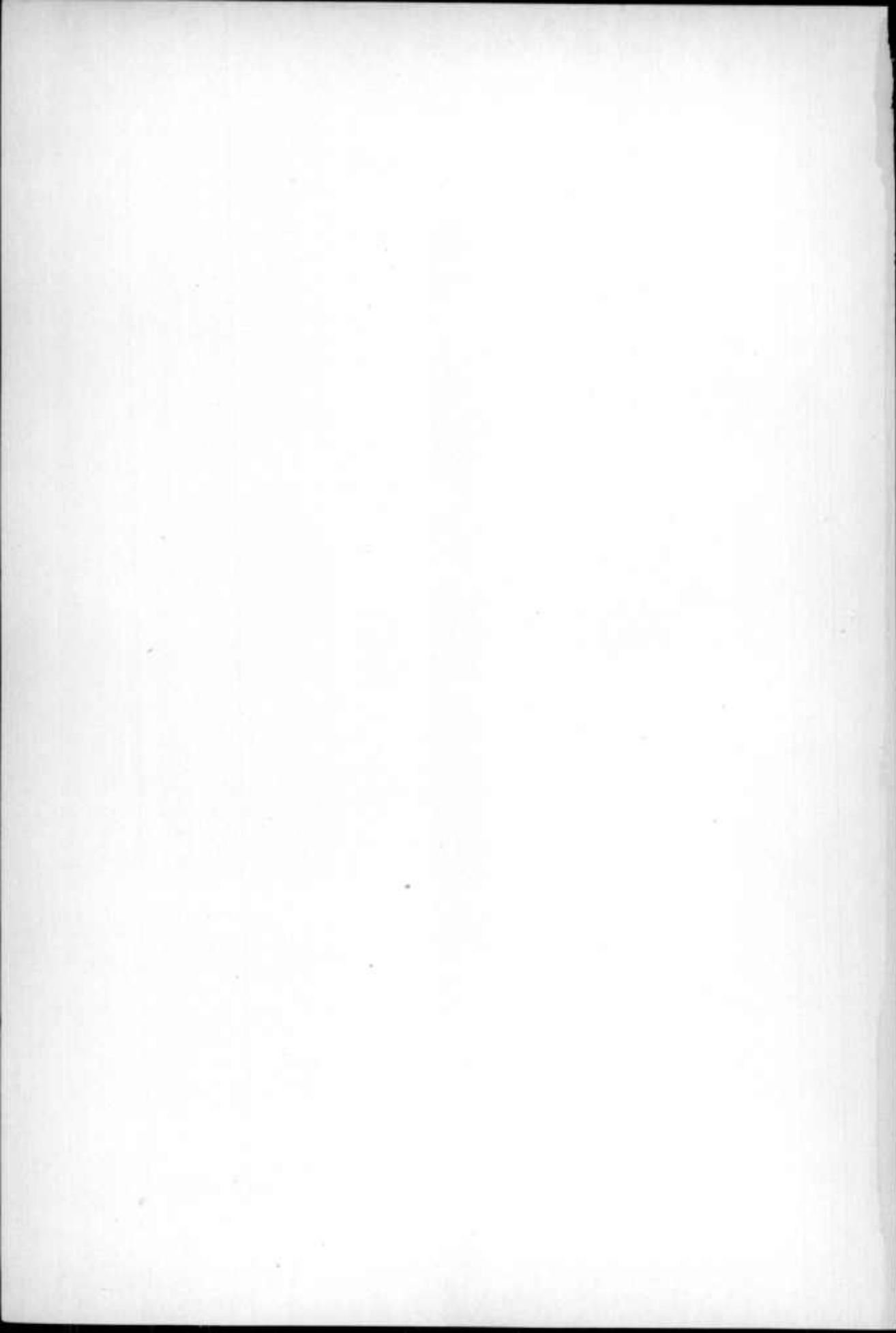

OPENING OF J. O. J. GREENE, ONE AND ONE-HALF MILES BELOW WESTERNPORT.

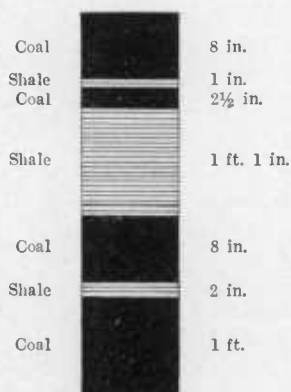

OPENING OF J. O. J. GREENE, OLD PHOENIX PLANE ADJOINING CATHOLIC CEMETERY, ONE-HALF MILE BELOW WESTERNPORT.

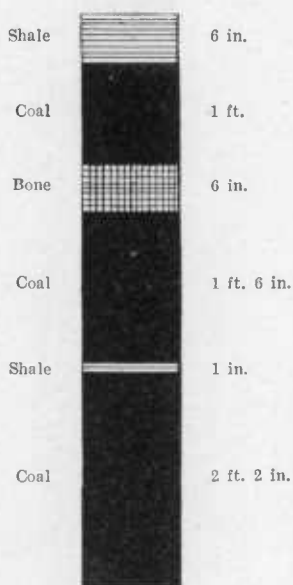

*Upper Kittanning coal.*—This seam which when present occurs from 35 to 65 feet above the top of the Lower Kittanning coal has not been recognized in the Georges Creek basin. It is an unimportant bed in Maryland although it has been recognized in the upper Potomac region and will be later discussed.

BUXTON MINE, DAVIS COAL AND COKE COMPANY, FRANKLIN HILL, ONE MILE WEST  
OF PIEDMONT, W. VA.

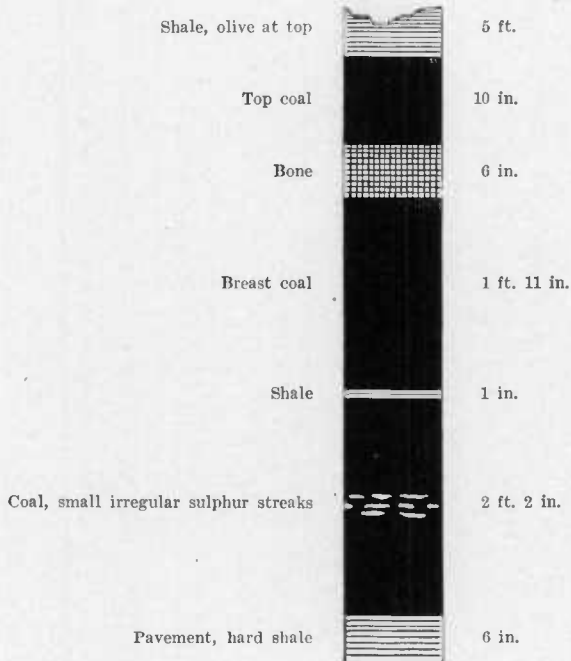

*Lower Freeport coal.*—This seam is of little importance in Maryland. It occurs at an interval of from 55 to 80 feet above the Upper Kittanning and from 100 to 145 feet above the Lower Kittanning coal and is commonly found from 35 to 60 feet below the top of the Allegheny formation. It is very variable in occurrence and has not been mined at any point in the Georges Creek valley.

*Sections of Lower Freeport Coal.*

SECTION IN SHORT GAP RUN, NEAR BARRELLVILLE.

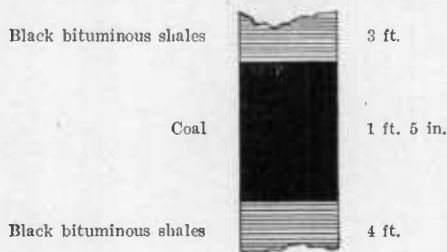

OLD GORMAN PLANE, NORTHWEST OF FRANKLIN.

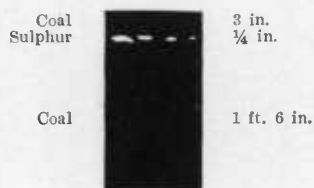

*Upper Freeport (Thomas or "Three-foot") coal.*—This seam occurs at the top of the Allegheny formation at an interval of from 20 to 60 feet below the Lower Mahoning sandstone and from 165 to 210 feet above the Lower Kittanning coal. It is locally known under the name of the "Three-foot" seam (or more frequently in the Georges Creek basin but less correctly, as the "Four-foot" seam). The Bakerstown seam, later described, is properly the "Four-foot" seam. This seam has also been called the "Thomas" coal by the geologists of the U. S. Geological Survey on account of its occurrence at Thomas, West Virginia. The Upper Freeport coal is a very persistent seam and commonly contains a clean workable bench of high-grade coal. It is somewhat variable in thickness and is in general much better developed in the Upper Potomac basin than in the Georges Creek basin.

*Sections of Upper Freeport Coal.*

JOHN SMITH'S FIRE-COAL OPENING, ONE MILE BELOW MOUNT SAVAGE.

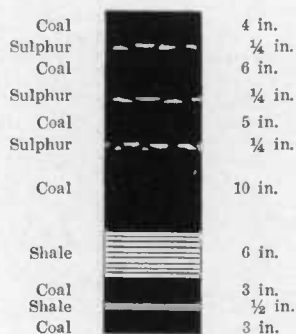

BRADDOCK COAL COMPANY, BRANT MINE, SHORT GAP RUN, ONE AND ONE-FOURTH MILES EAST OF CLARYSVILLE.

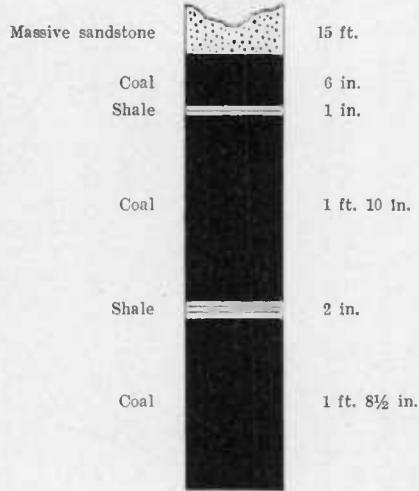

PROSPECT ON NORTH BANK OF BRADDOCK'S RUN ABOVE BRANTS RUN, ONE MILE EAST OF CLARYSVILLE.

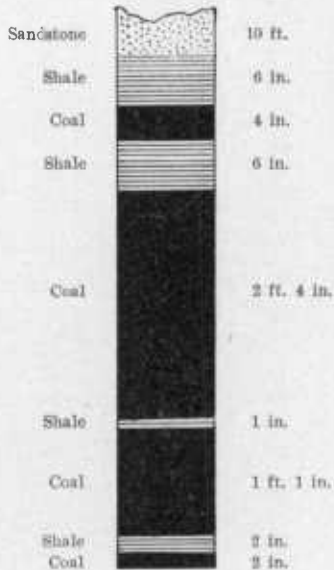

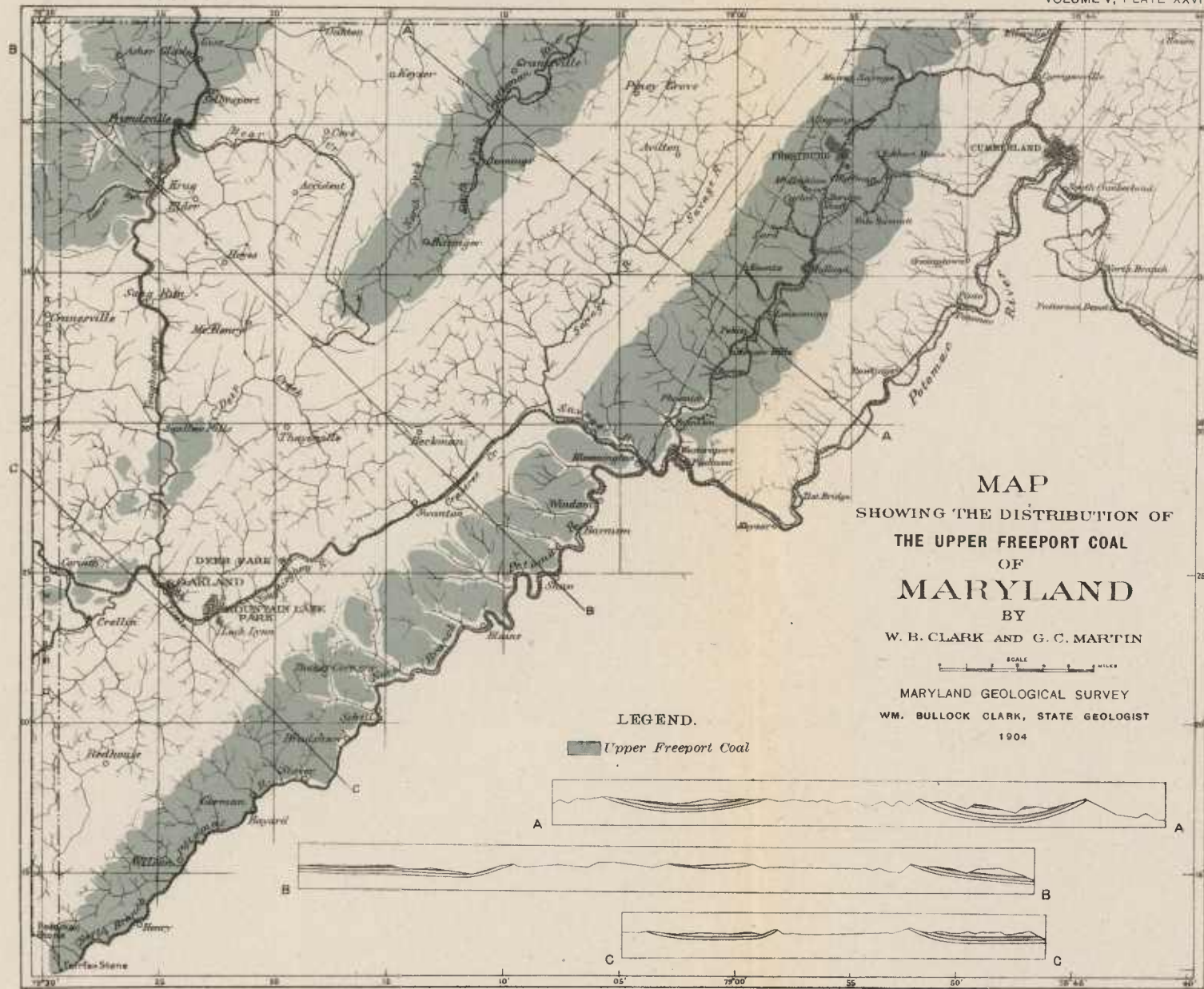

MAP  
SHOWING THE DISTRIBUTION OF  
THE UPPER FREEPORT COAL  
OF  
MARYLAND

BY  
W. B. CLARK AND G. C. MARTIN

MARYLAND GEOLOGICAL SURVEY  
WM. BULLOCK CLARK, STATE GEOLOGIST  
1904

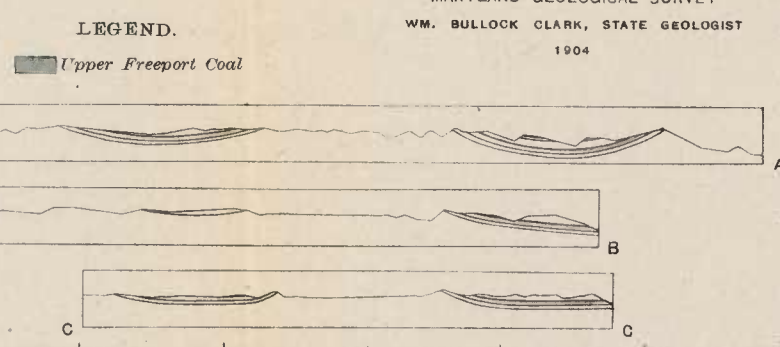

BUSKIRK FARM ON ELKCLICK RUN, ONE AND THREE-FOURTHS MILES SOUTHEAST OF GILMORE.

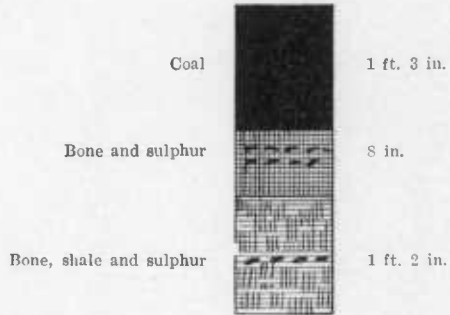

FIRE-COAL OPENING OF PETER MICHAEL'S FARM, MILL RUN, FOUR MILES WEST OF LONACONING.

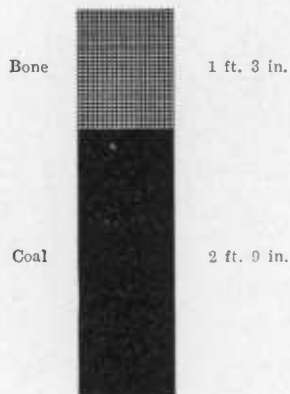

LOWER SEAM WORKED AT MORRISON BY FROSTBURG COAL MINING COMPANY, ONE MILE EAST OF PHOENIX.

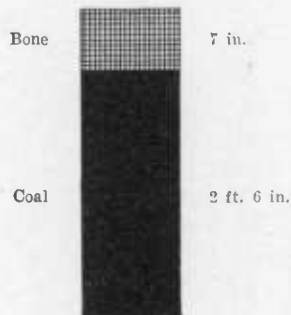



OLD FIRE-COAL OPENING NEAR OLD GORMAN PLANE, THREE-FOURTHS MILE NORTH-  
WEST OF FRANKLIN.

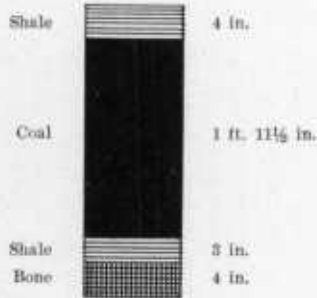

THE CONEMAUGH COALS OF THE GEORGES CREEK BASIN.

The Conemaugh coals are of less importance than the Allegheny coals and from the fact that the seams were not considered to possess economic value this formation was long known under the name of the Lower Barren Measures. Later study has shown, however, that the Conemaugh contains several seams which are either workable at present or are likely to become so in the future, but there is no reason to believe that the coal of the Conemaugh will ever rival that of the Allegheny in importance.

*Sections of Mahoning Coal.*

UNION MINING COMPANY, ONE AND ONE-FOURTH MILES NORTHWEST OF MOUNT SAVAGE.



*Mahoning coal.*—This seam, which when present, occurs between the Upper and Lower Mahoning sandstone at an interval of from 45 to 60 feet above the Upper Freeport coal, is very poorly developed in the Georges Creek basin. As will be shown later it has been found



in sufficient thickness in western Garrett county to possess some economic value locally and it may yet be found to occur in workable quantities in the Georges Creek area. There is, however, some question as to the determination of this coal in the Georges Creek region and the coal here referred to that seam may upon further examination be shown to belong elsewhere or to constitute a local seam which has no named equivalent elsewhere.

RIGHT BRANCH OF MOORES RUN, NEAR HENRY MOORE'S HOUSE, ONE AND ONE-HALF MILES EAST OF BARTON.

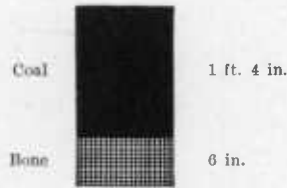

LEFT BANK MOORES RUN, ONE-HALF MILE ABOVE ISABEL MOORE'S, TWO MILES SOUTHEAST OF BARTON.

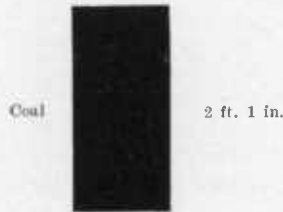

*Brush Creek (Masontown) coal.*—This seam occurs at an interval of about 65 feet above the Mahoning coal and from 85 to 125 feet

*Sections of Brush Creek Coal.*

OLD ORE TUNNEL, SECOND SEAM EXPOSED OUTWARD FROM FACE, ONE MILE NORTHWEST OF MOUNT SAVAGE.





above the Upper Freeport coal. It is a very persistent coal and the seam is generally from 18 to 24 inches in thickness although at times it exceeds this amount locally.





OLD ORE TUNNEL, THIRD SEAM OUTWARD FROM FACE, SAME LOCALITY.

Coal		4½ in.
Sulphur		¼ in.
Coal		5½ in.

OPENING TWO MILES SOUTHWEST OF BARRELVILLE.

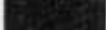
Black shales		28 ft.
Coal		10 in.
Black shales		2 ft.

BELOW MOUNT SAVAGE FIRE-CLAY PLANE, NEAR JOHN ORENDORFF'S HOUSE, ONE MILE NORTHWEST OF MOUNT SAVAGE.

Bone		3 in.
Coal		6 in.
Sulphur		½ in.
Coal		8 in.
Bone		8 in.

FIRE-COAL OPENING ON WM. COLEMAN'S PROPERTY, NORTHEAST BRANCH OF HILL RUN, TWO MILES EAST-SOUTHEAST OF LONACONING.

Coal		1 ft. 7 in.
------	---	-------------

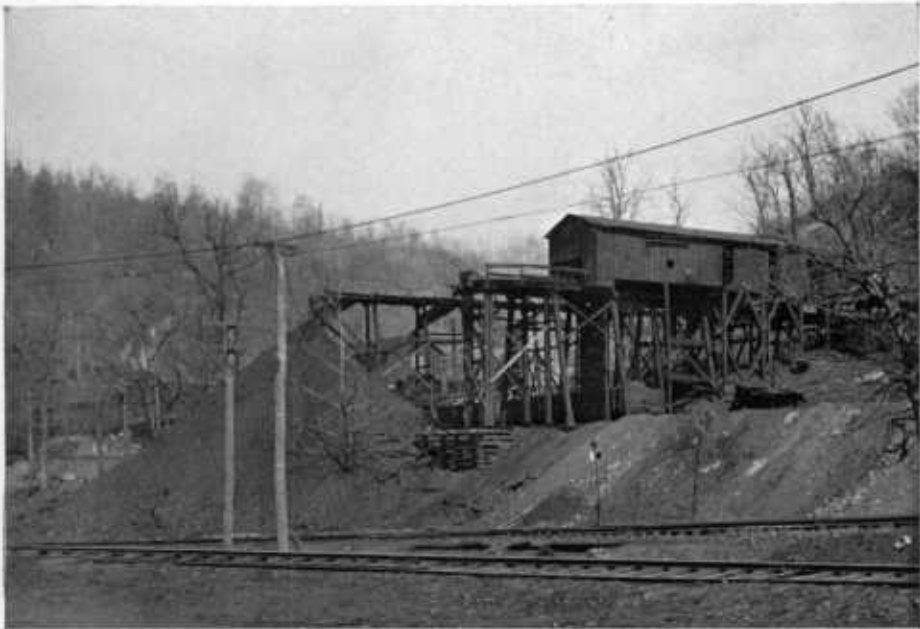

FIG. 1.—GEORGES CREEK COAL AND IRON COMPANY, GILMOR.



FIG. 2.—GEORGES CREEK COAL AND IRON COMPANY, GILMOR.

VIEWS OF COAL MINING PLANTS.

P.346 B

The text of this page is extremely faint and illegible. It appears to contain several paragraphs of text, but the characters are too light to be transcribed accurately. The layout suggests a standard page of prose with a few lines of text per paragraph.

PROSPECT OPENING ONE-EIGHTH MILE ABOVE HENRY MOORE'S HOUSE ON MOORES RUN, ONE AND ONE-HALF MILES EAST OF BARTON.

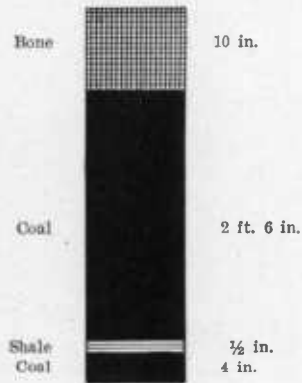

FIRE-COAL OPENING ON JOHN MOWBRAY'S PROPERTY, ONE-HALF MILE SOUTH OF BARTON.



OPENING ON HENRY MOORE'S PLACE, ON MOORES RUN, TWO MILES SOUTHEAST OF BARTON.

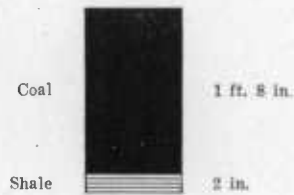

## SECTION ON MILL RUN, ONE-FOURTH MILE WEST OF ALLEGANY-GARRETT LINE.

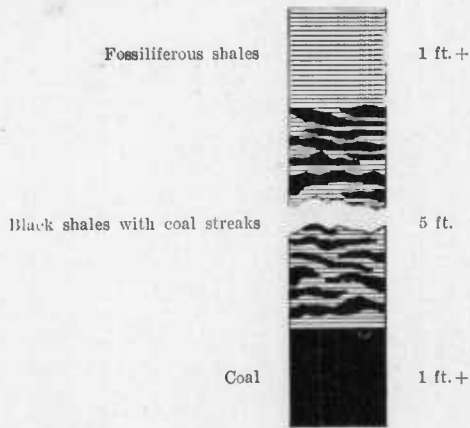

## OPENING ON J. O. J. GREENE'S PROPERTY, OPPOSITE HOUSE ON MILL RUN, ABOUT ONE MILE FROM THE MOUTH.

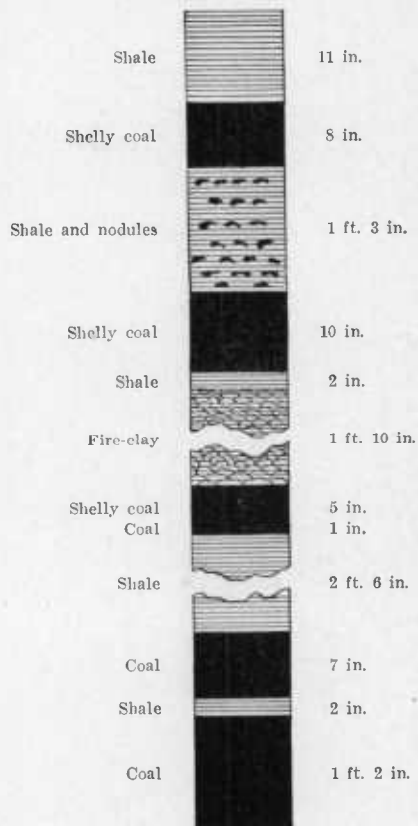

FIRE-COAL OPENING OF WILLIAM NEFF, MILL RUN, ONE MILE NORTH OF PHOENIX.

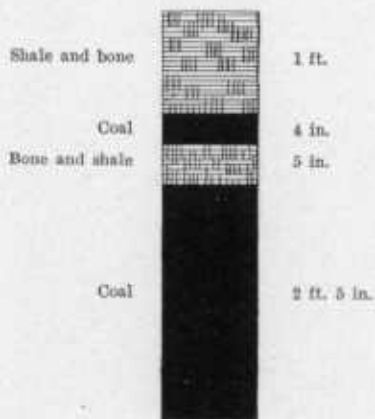

FIRE-COAL OPENING, ATHEY'S FARM, NEAR MORRISON, ONE MILE NORTH OF PHOENIX.

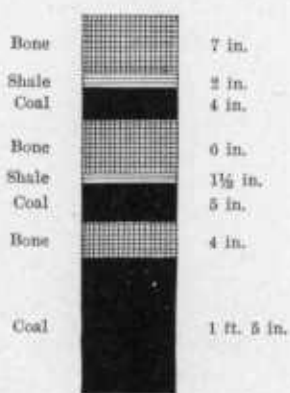

OPENING ON MIDDLE SEAM WORKED BY FROSTBURG COAL MINING COMPANY AT MORRISON, ONE MILE NORTH OF PHOENIX.

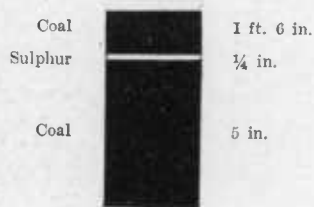

PROSPECT ABOVE MINE OF PIEDMONT AND GEORGES CREEK COAL COMPANY, THREE-EIGHTHIS MILE SOUTH OF FRANKLIN.

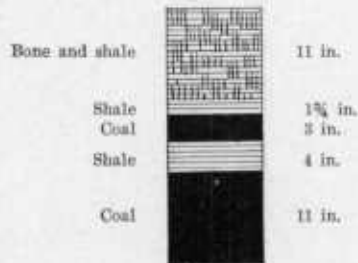

*Bakerstown (Barton or "Four-foot") coal.*—This seam occurs at an interval of from 90 to 135 feet above the Brush Creek coal. It is known locally as the "Four-foot" coal (or more frequently in the Georges Creek basin but less correctly as the "Three-foot"). The Upper Freeport, earlier described, is properly the "Three-foot" seam. This seam is somewhat variable in its thickness but is very persistent and in its thickest areas has much economic value and will probably be extensively mined under such conditions in the future.

*Sections of Bakerstown Coal.*

OLD ORE OPENING, FOURTH SEAM OUTWARD FROM FACE, ONE MILE NORTHWEST OF MOUNT SAVAGE.

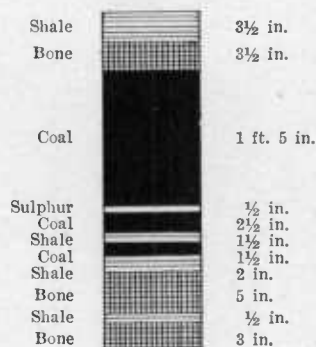



OLD UNION No. 2, NEAR FOOT OF MOUNT SAVAGE PLANE, ONE AND ONE-FOURTH MILES NORTHWEST OF MOUNT SAVAGE.

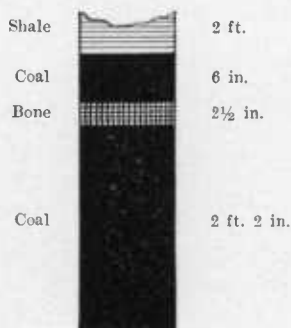

PROSPECT HOLE, THREE-FOURTHS MILE WEST OF BARRELVILLE.

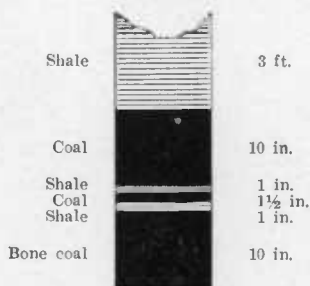

PROSPECT NEAR MOUTH OF TROTTERS RUN, THREE-FOURTHS MILE SOUTHWEST OF BARRELVILLE.

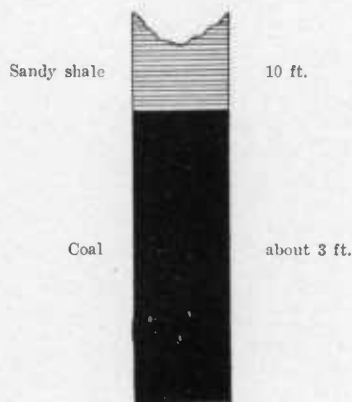

PINCHER'S COAL OPENING, TROTTERS RUN, TWO MILES NORTHEAST OF ECKHART MINE.

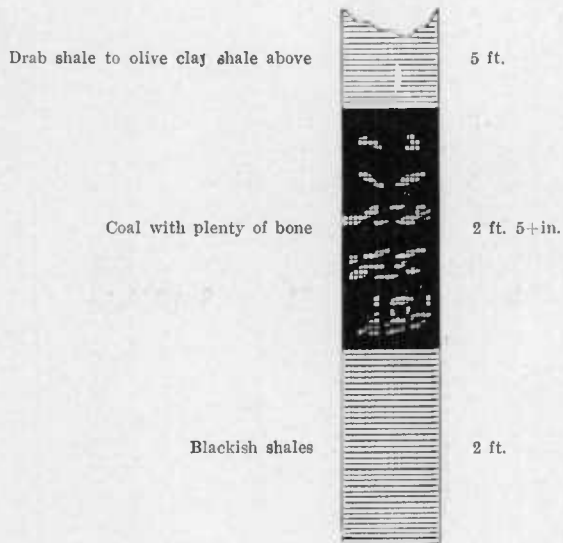

OPENING ON MOUNTAIN BEHIND TAVERN AT CLARYSVILLE, C. & P. R. R., HALF WAY BETWEEN POWER STATION AND TAVERN.

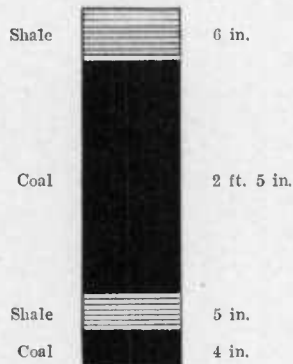

OPENING NEAR OLD SUGAR CAMP, ONE-HALF MILE NORTH OF LOARVILLE.

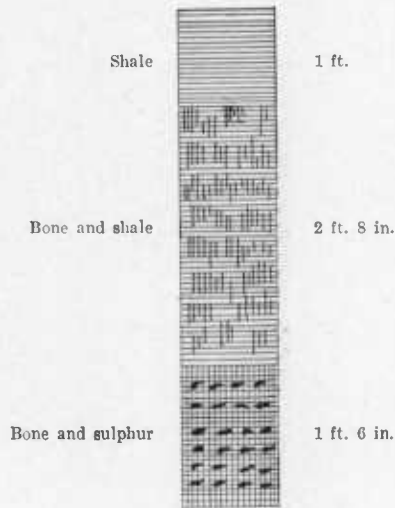

MARYLAND COAL COMPANY NEAR BEAMAN SAWMILL ON CASTLE RUN, ONE-HALF MILE ABOVE KOONTZ.

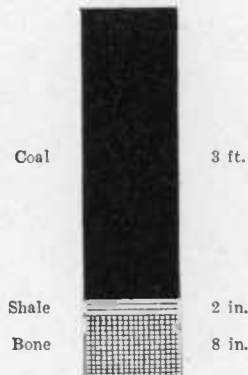

## OPENING NEAR JAMES MIER'S HOUSE, COUNTY ROAD ABOVE LONACONING.

OPENING ON ROAD TO LAUREL RUN, 100 YARDS BELOW HUGH McMULLEN'S HOUSE,  
THREE MILES WEST OF LONACONING.



FIG. 1.—NEW CENTRAL COAL COMPANY, KOONTZ.

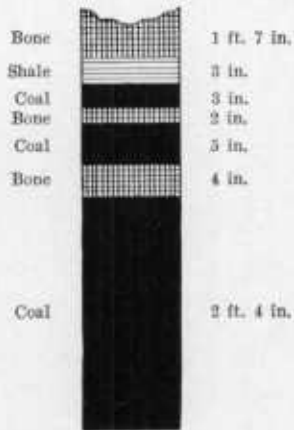
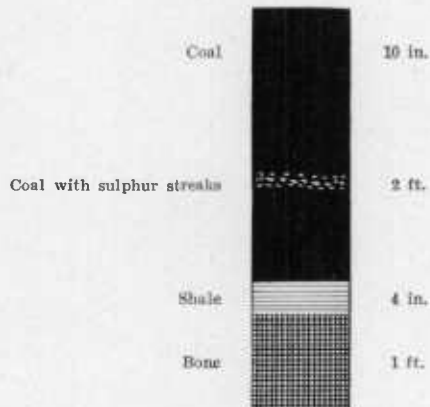
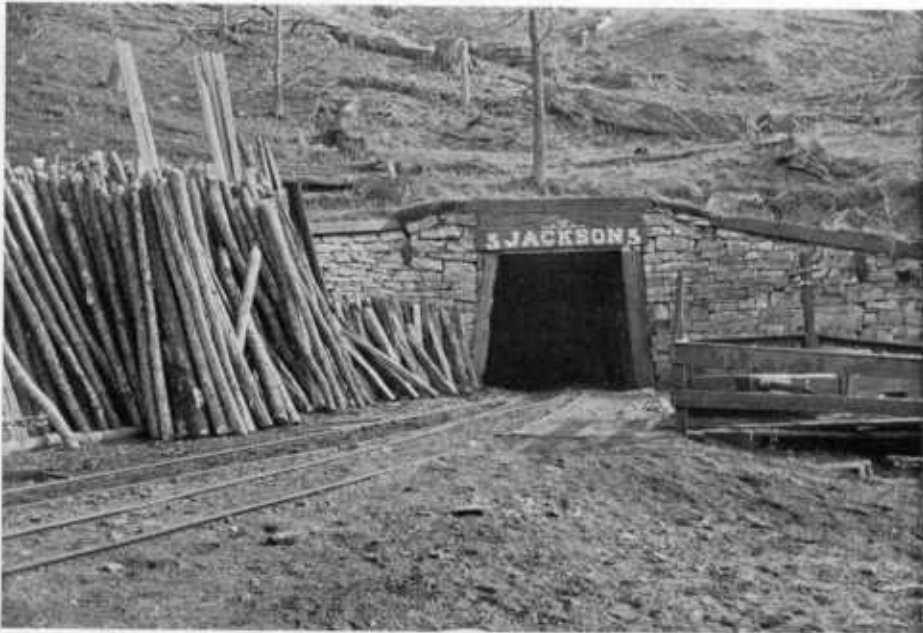
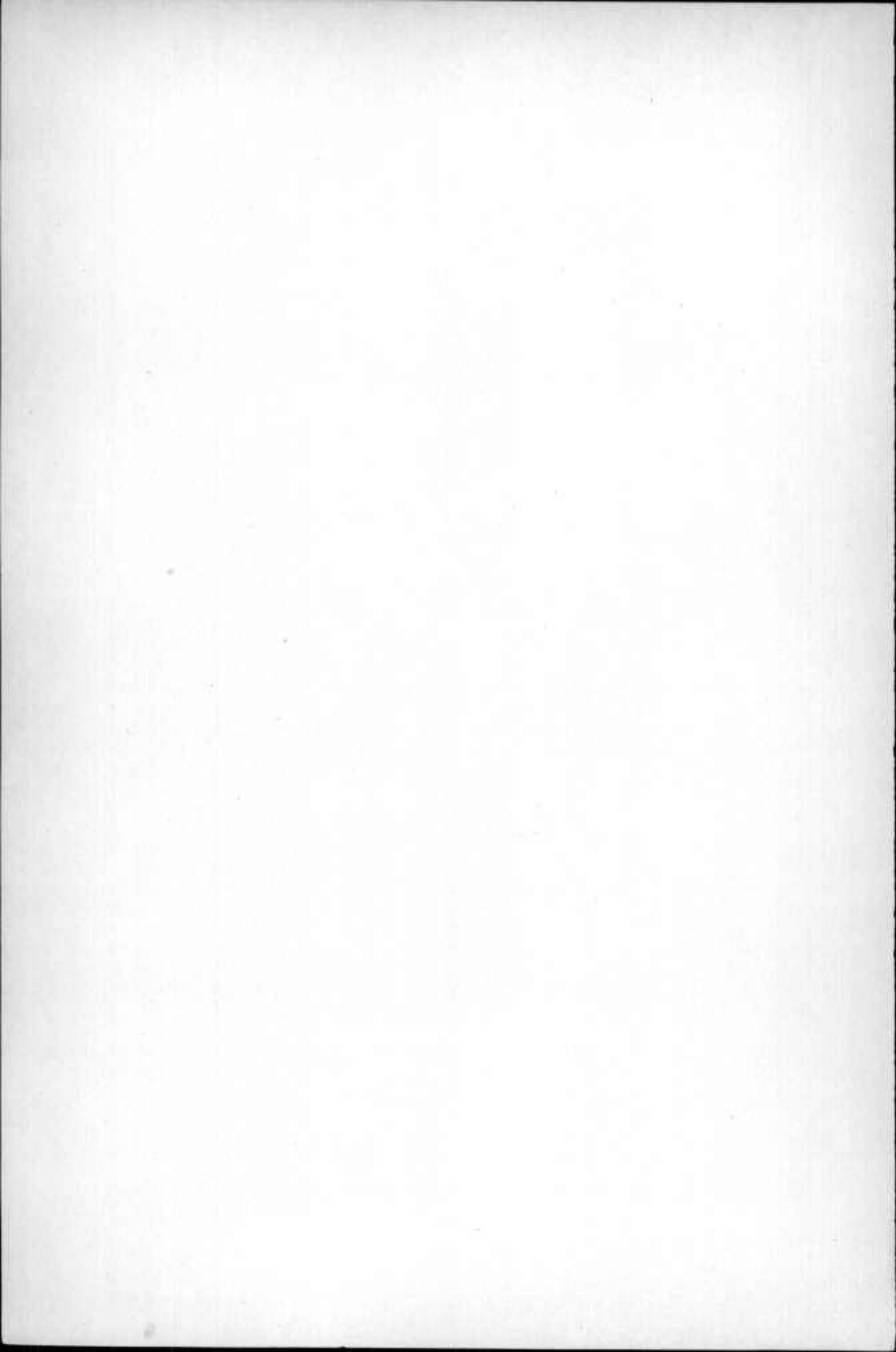

FIG. 2.—AMERICAN COAL COMPANY, JACKSON NO. 5.

VIEWS OF COAL MINING PLANTS.

P. 354. B



JAMES WIER'S MINE ON LAUREL RUN, THREE MILES WEST OF LONACONING.

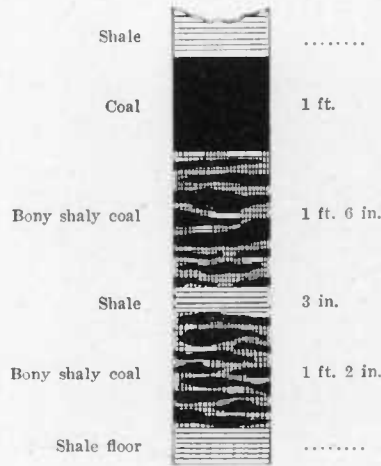

MINE, THREE-FOURTHS MILE NORTHWEST OF TOP OF DETMOLD HILL.

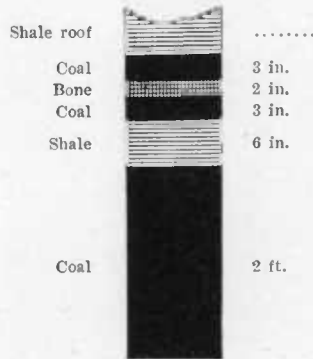

## PHILLIP HANSELL'S FARM, THREE AND ONE-HALF MILES WEST OF LONACONING.

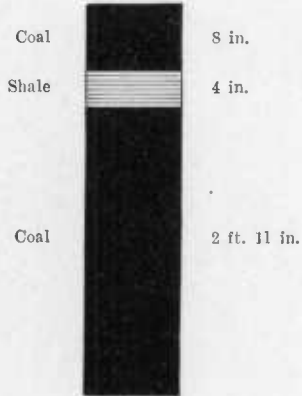

## OPENING ON ARCHIE RUSSELL'S FARM, ON BARTLETT RUN, NEAR BARTON.

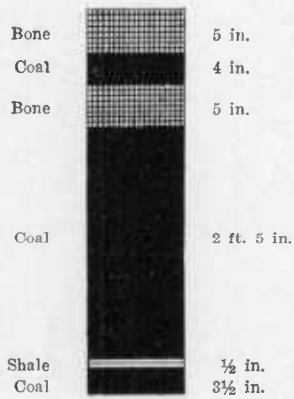



FIRE-COAL OPENING OF NOAH NEAT, ON BARTLETT RUN, NEAR BARTON.

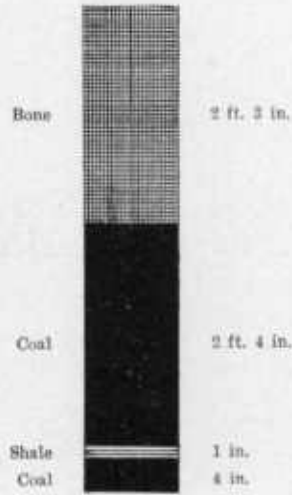

OPENING OF GEORGE LANGAN, ON BARTLETT RUN, NEAR BARTON.

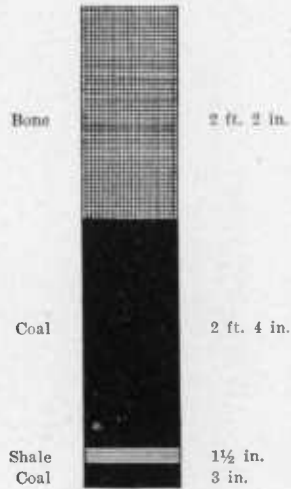

OPENING IN REAR OF HOUSE BELOW C. & P. R. R. BRIDGE BETWEEN PEKIN AND  
MOSCOW.

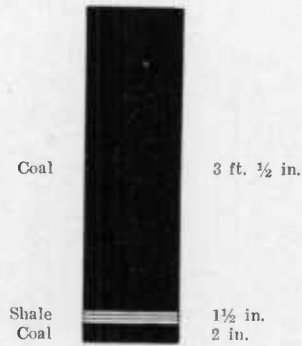

OLD FIRE-COAL OPENING, THREE HUNDRED FEET SOUTHEAST OF C. & P. R. R.  
BRIDGE, BETWEEN PEKIN AND MOSCOW.

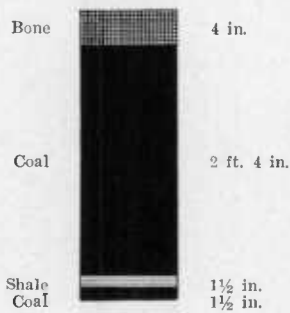

BEHIND MEYER'S HOUSE, NEAR MOUTH OF LAUREL RUN, MOSCOW MILLS.

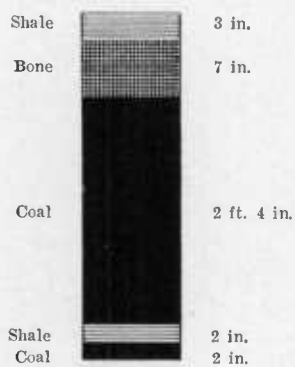

OPENING OF A. B. SHAW NEAR MOUTH OF LAUREL RUN, ONE-HALF MILE NORTH OF BARTON.

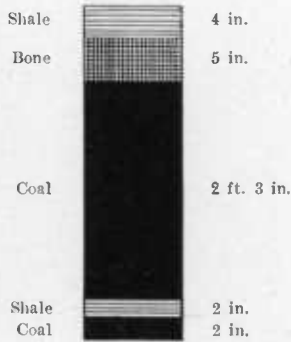

OPENING OF A. B. SHAW, ON COUNTY ROAD NEAR BARTON, FOUR HUNDRED FEET FROM MOUTH.

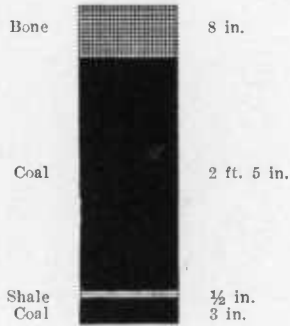

OPENING ON MOUNTAIN OPPOSITE SAWMILL, NEAR FORKS OF MILL RUN, THREE MILES NORTHWEST OF BARTON.

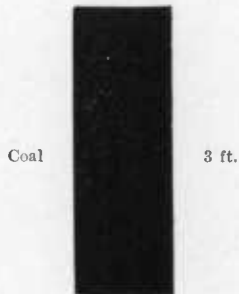

## MOSCOW-GEORGES CREEK MINING COMPANY AT BARTON.

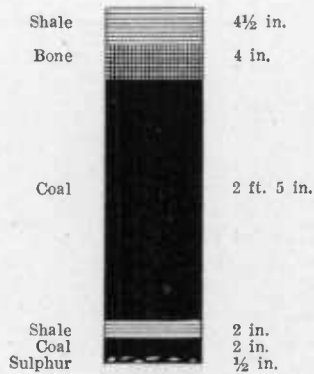

## CHAPMAN OPENING, OLD SWANTON MINE, BARTON.

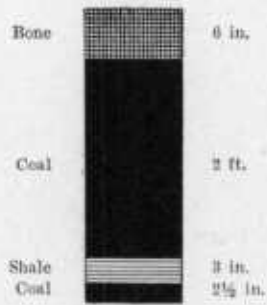

## FIRE-COAL OPENING OF M. N. FAZENBAKER, NEAR FORK OF MILL RUN, THREE MILES WEST OF BARTON.

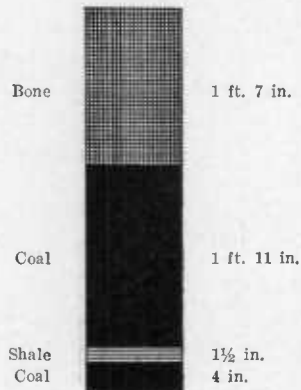

POTOMAC MINE OF UNION MINING COMPANY, NEAR BARTON.

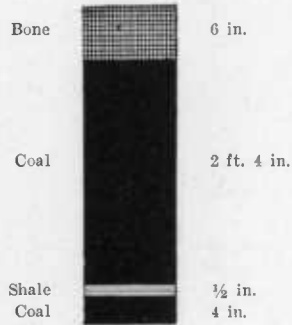

OPENING ON MOORES RUN, MIDWAY BETWEEN POTOMAC FAN HOUSE AND DOG TOWN, ONE MILE EAST OF BARTON.

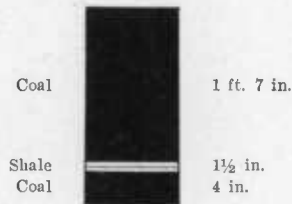

FIRE-COAL OPENING OF SAMUEL ROSS, ONE-HALF MILE SOUTHEAST OF BARTON.

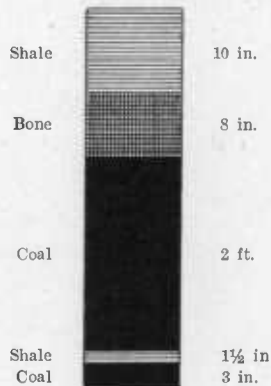

OPENING OF HENRY MOORE, MOORES RUN, ONE AND THREE-FOURTHS MILE EAST  
OF BARTON.

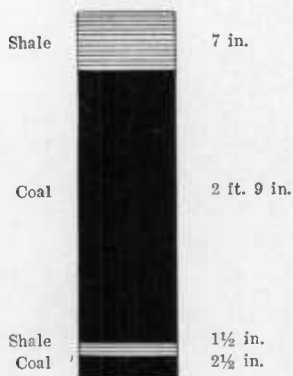

OLD FIRE-COAL OPENING OF ISABEL MYER, MOORES RUN, ABOUT ONE-HALF MILE  
BELOW FORKS, TWO MILES EAST OF BARTON.

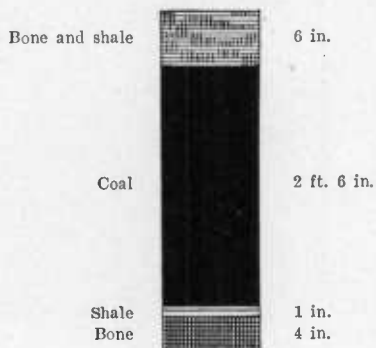

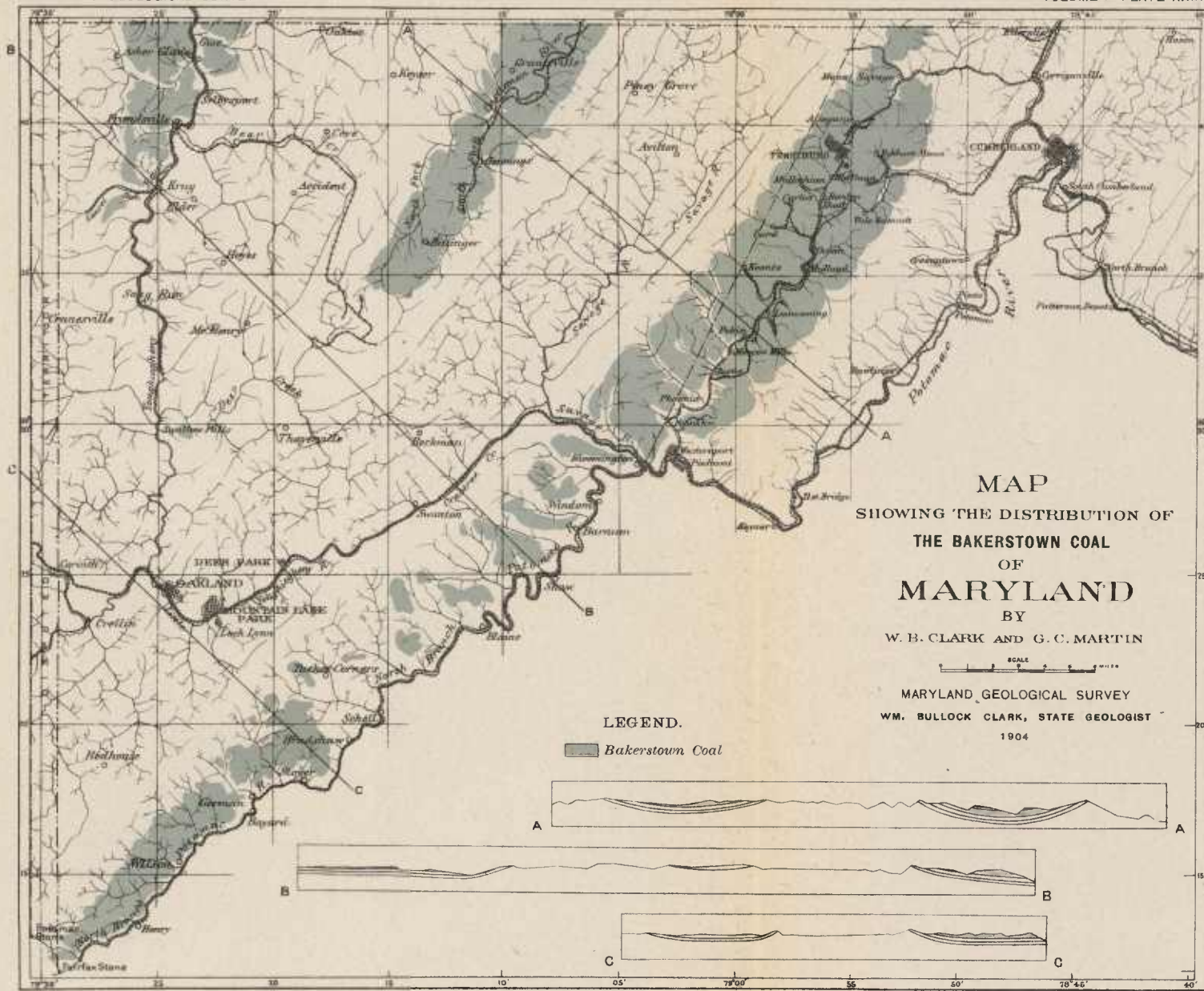

P. 362 B



MINE ON SOUTH BRANCH OF MILL RUN, ONE MILE NORTHEAST OF BARTON.

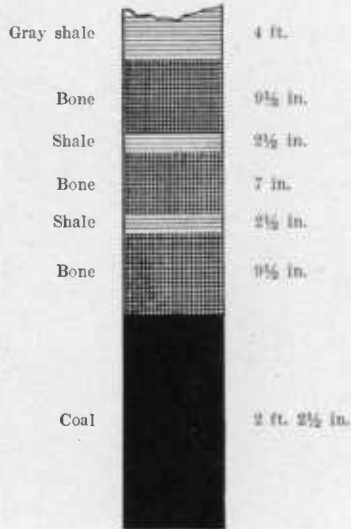

OPENING ON MICHAELS RUN BELOW EZRA MICHAEL'S HOUSE, MILL RUN, ONE MILE NORTHWEST OF PHOENIX.

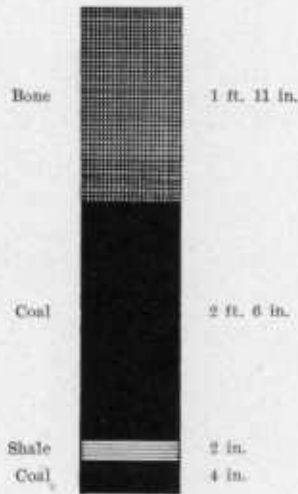



FIRE-COAL OPENING NEAR T. P. MICHAEL'S HOUSE ON AARON RUN, FOUR AND ONE-HALF MILES NORTHWEST OF WESTERNPORT.

Coal		2 in.
Sulphur		¼ in.
Coal		2½ in.
Bone and shale		4 in.
Bony coal		3 in.
Shale		½ in.
Bony coal		1 in.
Shale		2 in.
Bony coal		3 in.
Shale		7 in.
Coal		1½ in.
Cannel coal		2 in.
Coal		2 ft. 8 in.

FIRE-COAL OPENING OF FAZENBAKER ON AARON RUN, ABOUT FOUR MILES NORTHWEST OF WESTERNPORT.

Bone		1 ft. 5 in.
Coal		8 in.
Sulphur		¼ in.
Coal		1 ft. 9 in.
Bone		4 in.

PHOENIX AND GEORGES CREEK MINING COMPANY'S PROPERTY NEAR PHOENIX.

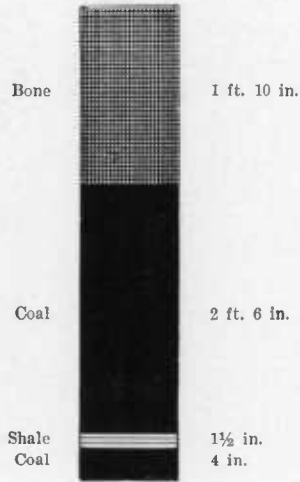

OPENING OF FROSTBURG COAL MINING COMPANY, ONE MILE NORTH OF PHOENIX.

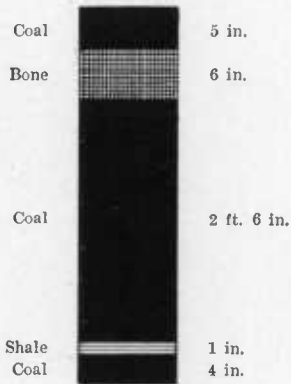

VAN BOYNEBURK'S OPENING OF CUMBERLAND AND GEORGES CREEK COAL COMPANY  
NEAR FRANKLIN.

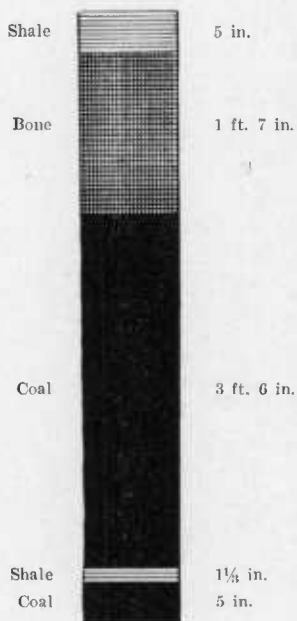

CUMBERLAND-GEORGES CREEK COAL COMPANY'S MINE ABOVE FRANKLIN.

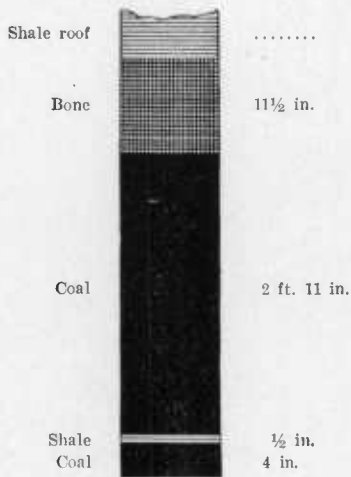

FIRE-COAL OPENING OF JAMES GROVE ON AARON RUN, FOUR MILES NORTHWEST OF WESTERNPORT.

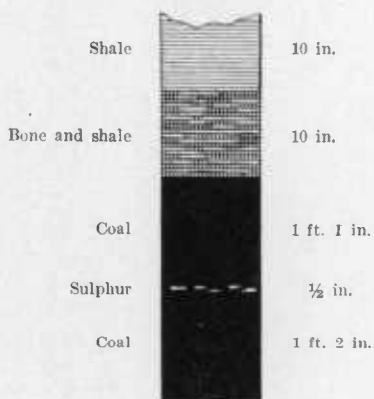

FIRE-COAL OPENING NORTH OF OLD FRANKLIN PLANE, ONE-HALF MILE WEST OF FRANKLIN.

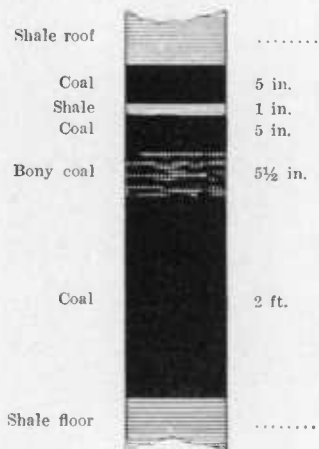

## FIRE-COAL OPENING OF M. GANNON BETWEEN OLD FRANKLIN PLANE AND OLD GORMAN PLANE, FRANKLIN.

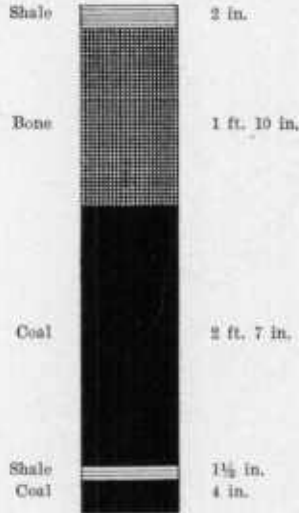

## HILL ABOVE MINE OF PIEDMONT AND GEORGES CREEK COAL COMPANY, FRANKLIN.

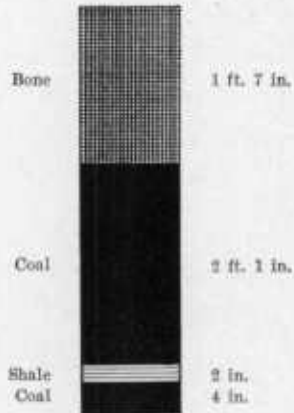

*Friendsville (Crinoidal) coal.*—This seam occurs at an interval of about 100 feet above the Bakerstown coal in the Georges Creek basin. It is best developed in the northern part of the basin where the coal occurs in variable thickness and was already mined at an early period. It is better developed in this area than in any other part of the State. This coal is known under the name of the Cri-

noidal coal in Pennsylvania, but as it is well developed in the vicinity of Friendsville, Garrett county, that name has been applied to it in Maryland in order that all of the names may conform in origin.

*Section of Friendsville Coal.*

FIRE-COAL OPENING ECKHART BRANCH C. & P. R. R., CLARYSVILLE.

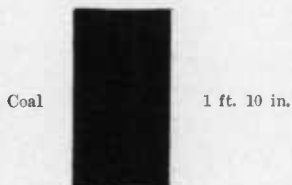

*Ellick coal.*—This seam occurs at an interval of about 35 feet above the Friendsville coal when present but does not occur at any point in Maryland in sufficient thickness to have any commercial value. It is generally an irregular seam a few inches in thickness.



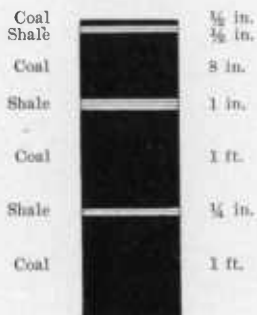

*Lonaconing coal.*—This seam has only been found in the lower central portion of the Georges Creek basin. It occurs just below the Clarksburg limestone and where best developed shows a thickness of about 2 feet. It is possible that it may locally prove to have some commercial value although the extent of the coal beyond a few points where it is exposed cannot be determined in the present state of development of the region.

*Sections of Lonaconing Coal.*

LOWER OPENING (ABANDONED) ON TRIMBLE FARM, NEAR MORANTOWN, THREE-FOURTHS MILE SOUTHEAST OF MOUNT SAVAGE.



SECTIONS OF LOWER OPENING, ONE HUNDRED YARDS NORTHEAST OF BARN, TRIMBLE  
HOMESTEAD, THREE-FOURTHS MILE NORTHEAST OF MOUNT SAVAGE.

Coal		4 in.
Shale		2½ to 3 in.
Coal		1 ft. 7 in.
Shale		½ in.
Coal		1 ft. 5 in.

NEW CENTRAL COAL COMPANY, NEAR KOONTZ.

Coal		2 ft.
------	---	-------

OPENING OPPOSITE TRESTLE AT MINE NO. 1 OF GEORGES CREEK COAL AND IRON  
COMPANY'S PROPERTY, ONE MILE NORTH OF LONACONING.

Coal		1 ft. 3½ in.
------	---	--------------



FIG. 1.—PIEDMONT MINING COMPANY, MOSCOW.



FIG. 2.—MARYLAND COAL COMPANY, APPLETON.

VIEWS OF COAL MINING PLANTS.



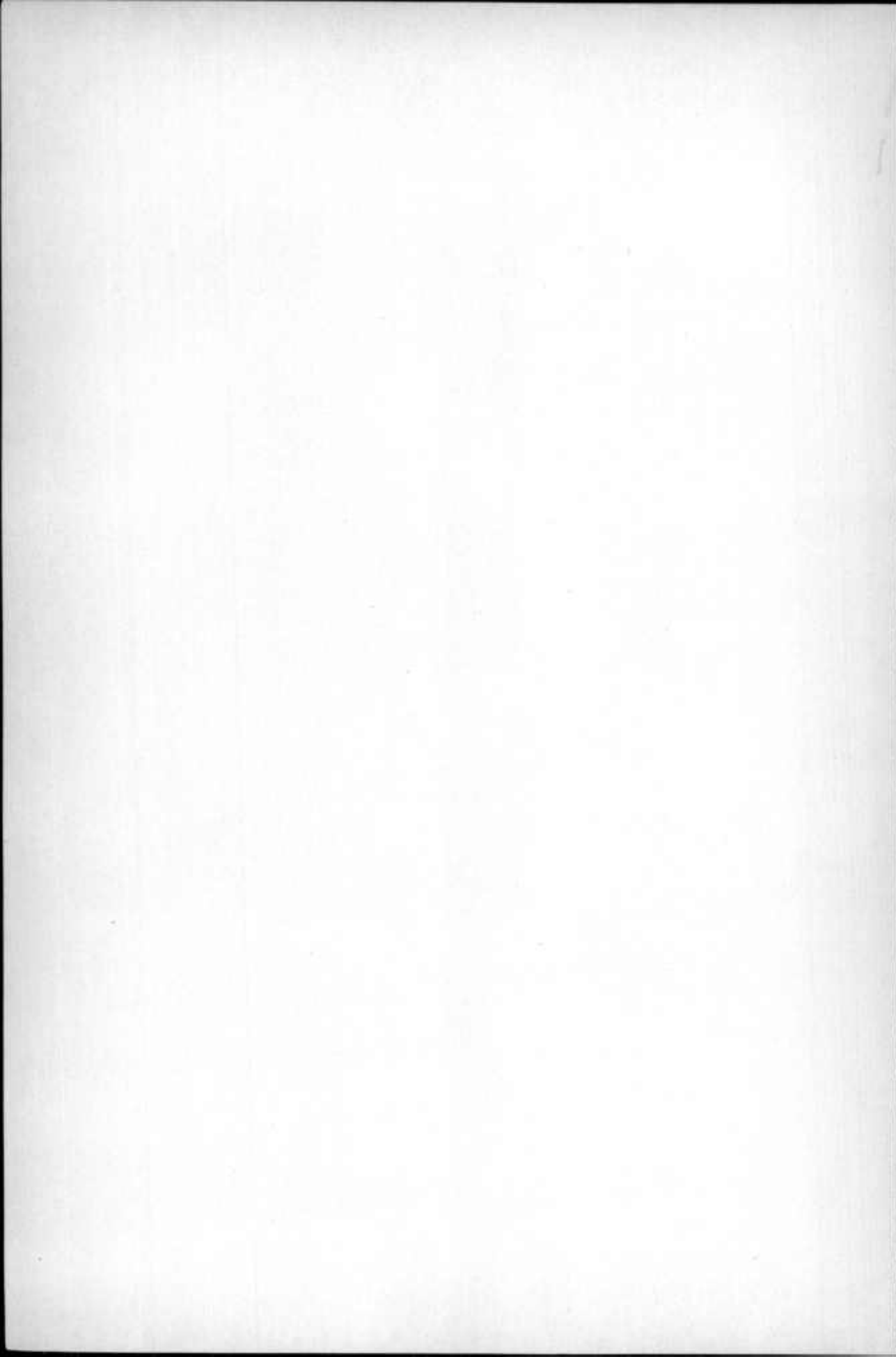

OUTCROP BEHIND THOMAS PEEBLE'S HOUSE, LONACONING.

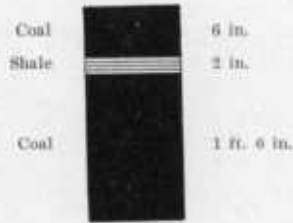

NEW CENTRAL COAL COMPANY, BIG VEIN HILL, LONACONING.

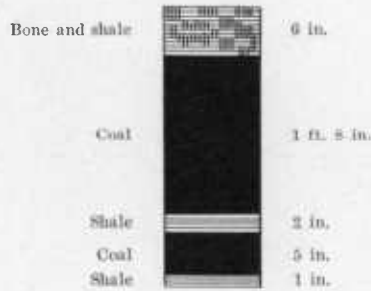

PROPERTY OF MR. HOHNG, DETMOLD HILL, NEAR LONACONING.

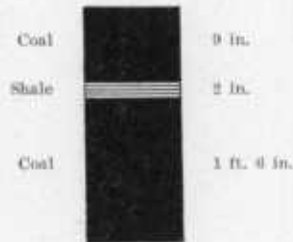

*Franklin (Little Clarksburg or "Dirty-nine-foot") coal.*—This seam occurs at an interval of from 50 to 100 feet above the Elklick coal and about 150 feet below the Pittsburg or "Big Vein." It is probably identical with the Little Clarksburg coal of West Virginia and is popularly called the "Dirty-nine-foot" by the miners in the Georges Creek basin.

*Sections of Franklin Coal.*

UPPER OPENING (ABANDONED), SIXTY FEET ABOVE LOWER OPENING, TRIMBLE'S FARM, THREE-FOURTHS MILE SOUTHEAST OF MOUNT SAVAGE.

Shale and coal		11 in.
Shale		$\frac{1}{4}$ in.
Coal		3 in.
Shale		$3\frac{1}{2}$ in.
Bone		4 in.
Shale		$\frac{1}{4}$ in.
Bone and shale		4 in.
Shale		$\frac{1}{2}$ in.
Bone		$2\frac{1}{2}$ in.
Bone and shale		10 in.
Coal		3 in.
Shale		10 in.
Coal		1 ft.

FIRE-COAL OPENING NEAR TENANT HOUSE, TRIMBLE FARM, THREE-FOURTHS MILE SOUTHEAST OF MOUNT SAVAGE.

Draw shale		2 in.
Coal		11 in.
Sulphur		$\frac{1}{4}$ in.
Coal		5 in.
Sulphur		$\frac{1}{4}$ in.
Coal		4 in.
Sulphur		$\frac{1}{4}$ in.
Coal		$4\frac{1}{2}$ in.
Bone and shale		5 in.
Fire-clay		1 ft. 2 in.
Coal		11 in.

GEORGES CREEK COAL AND IRON COMPANY, ONE AND ONE-HALF MILES NORTH OF LONACONING.

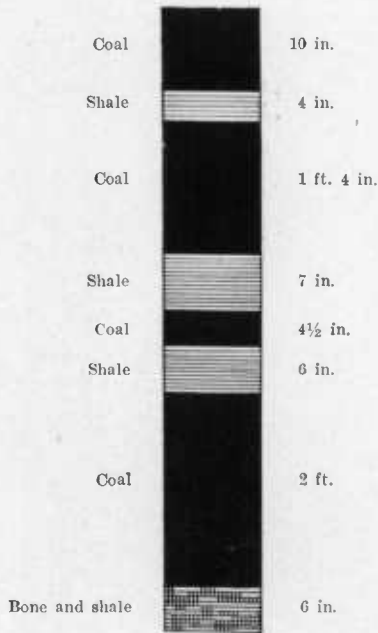

PROSPECT OPENING NEAR OLD GORMAN PLANE, ONE AND ONE-FOURTH MILES NORTHWEST OF FRANKLIN.

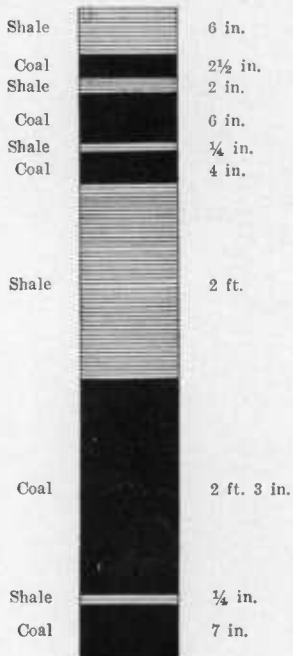

## REPORT ON THE COALS OF MARYLAND

## AMERICAN COAL COMPANY NEAR CALEDONIA MINE AT BARTON.

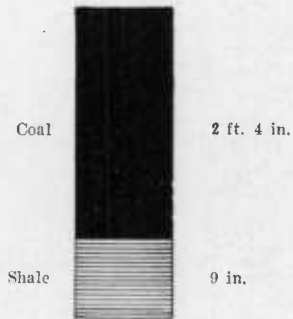

## POTOMAC COAL COMPANY, MOORES RUN, THREE-FOURTHS MILE EAST OF BARTON.

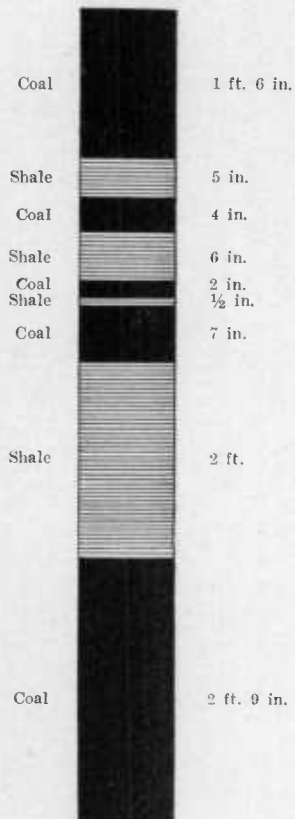

OLD FRANKLIN PLANE, ONE MILE WEST OF FRANKLIN.

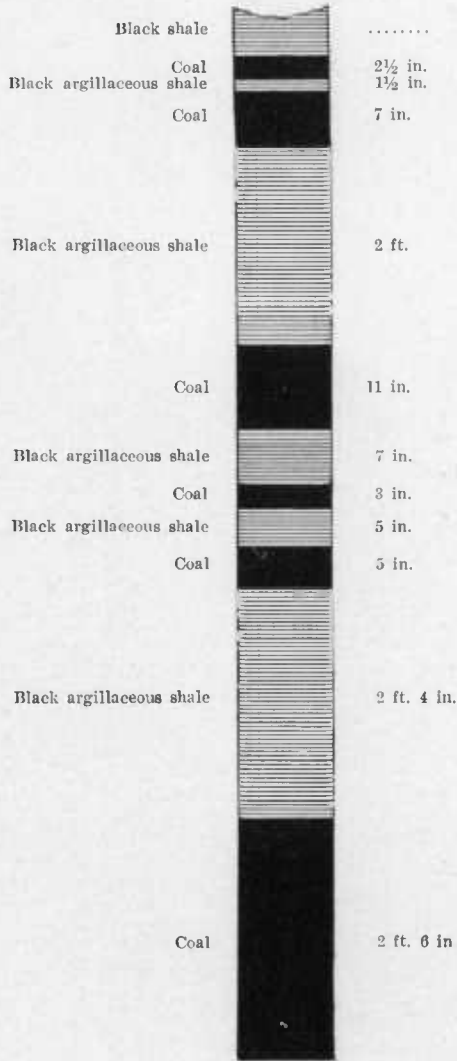

## LOWER PART OF SEAM OPENED AT TOP OF OLD FRANKLIN PLANE, ONE MILE WEST OF FRANKLIN.

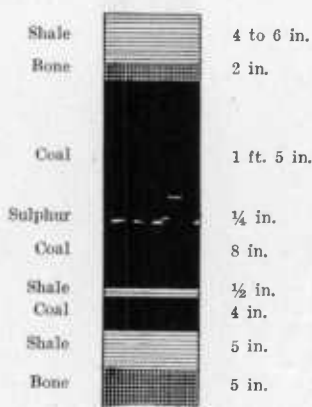

*Little Pittsburg coal.*—This seam is generally constant in position from 50 to 90 feet below the “Big Vein.” This seam at times attains a thickness of about 3 feet although it is often broken up by partings of shale and sulphur. Some times it is divided into two clearly marked seams by the increase of the shale parting to several feet in thickness. The lower seam is then referred to as the second Little Pittsburg. This seam is evidently equivalent to the Little Pittsburg of Pennsylvania.

*Sections of Little Pittsburg Coal.*

NEW CENTRAL COAL COMPANY, “BONNEY MINE,” OPPOSITE LONACONING.

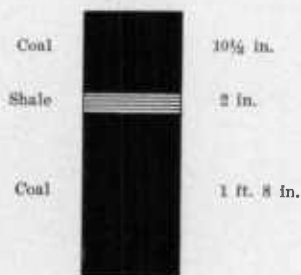

AMERICAN COAL COMPANY, SIXTY FEET BELOW "BIG VEIN," EAST OF PEKIN.

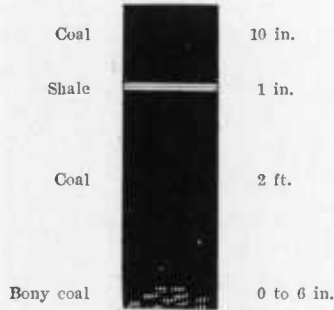

VEIN ABOUT SEVENTY FEET BELOW "BIG VEIN" AT POTOMAC COAL COMPANY'S MINE, ONE-HALF MILE NORTH OF MOSCOW MILLS.

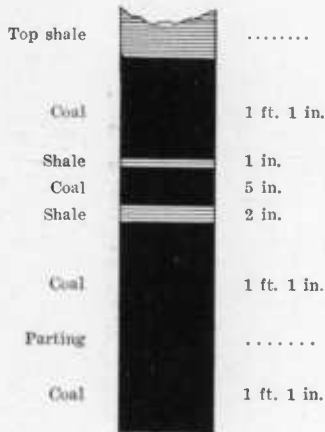

PROSPECT OPENING AT OLD POTOMAC "BIG VEIN" PLANE, SEVENTY-FIVE FEET FROM MOUTH, ONE-HALF MILE NORTH OF MOSCOW MILLS.

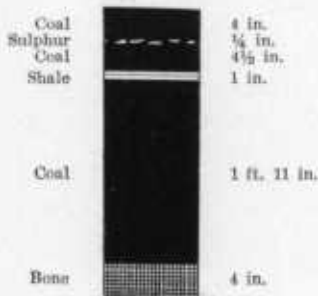



OLD PROSPECT OPENING ON OLD BARTON PLANE, FIFTY FEET FROM MOUTH, ONE MILE EAST OF BARTON.

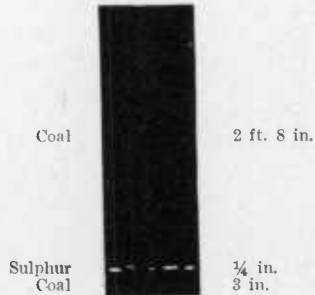

OPENING BEHIND EZRA MICHAEL'S HOUSE, MILL RUN, TWO MILES NORTHWEST OF FRANKLIN.

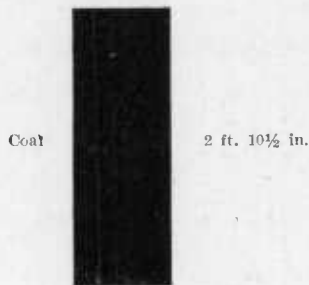

OPENING OF O. C. FAZENBAKER'S, BETWEEN MILL RUN AND OLD FRANKLIN PLANE, ONE-HALF MILE FROM ROCK CHURCH, TWO MILES NORTHWEST OF FRANKLIN.

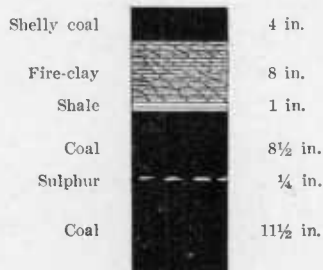

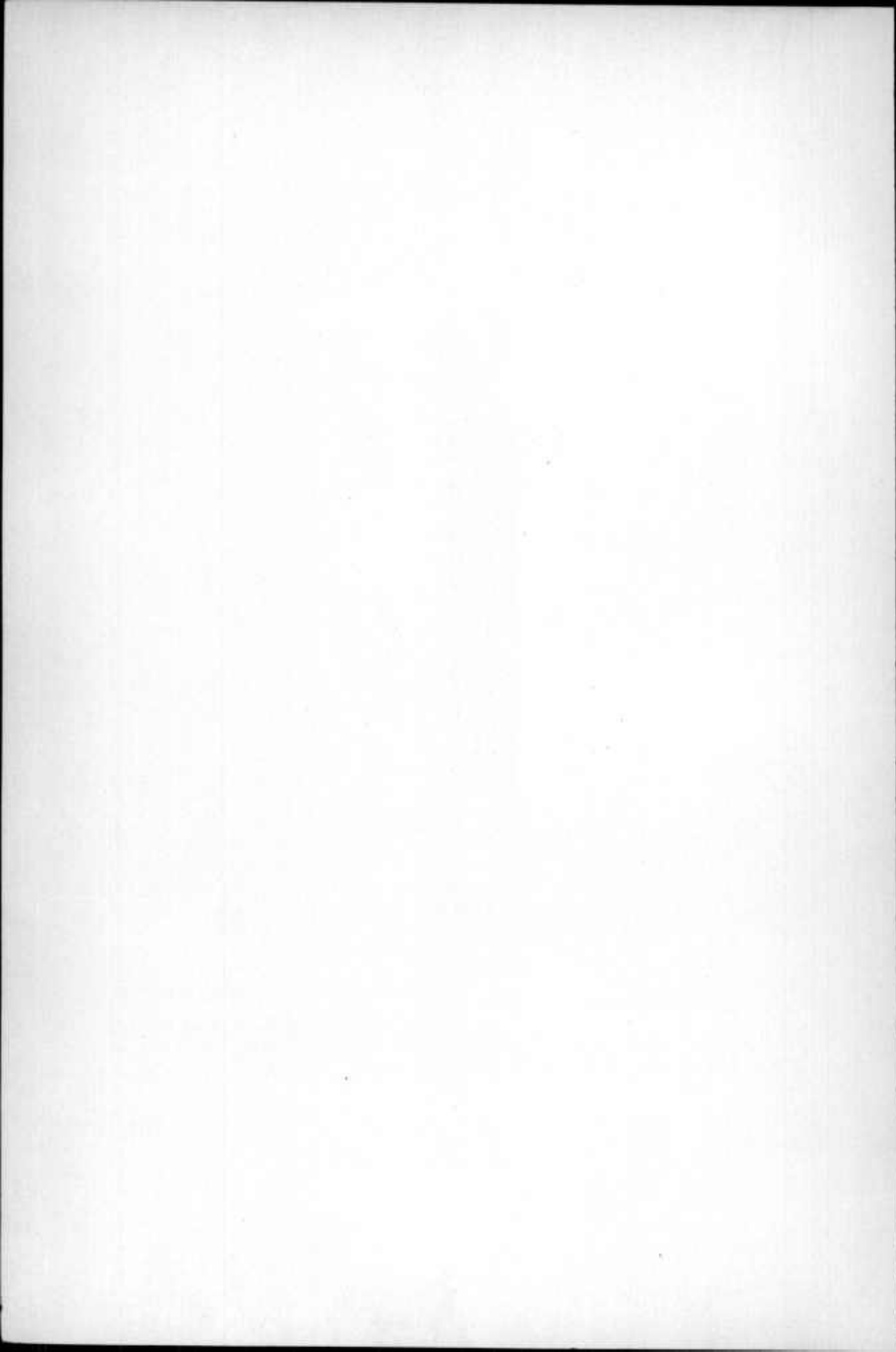

FIG. 1.—DAVIS COAL AND COKE COMPANY, HENRY NO. 1.



FIG. 2.—DAVIS COAL AND COKE COMPANY, HENRY.

VIEWS OF COAL MINING PLANTS.



## THE MONONGAHELA COALS OF THE GEORGES CREEK BASIN.

The Monongahela coals are practically confined to the Georges Creek basin, a small area long since exhausted being found also in the Potomac basin. The Monongahela coals have had, and will con-

*Sections of Pittsburg Coal.*

GEORGES CREEK AND BALD KNOB COAL COMPANY, NORTH OF MOUNT SAVAGE.

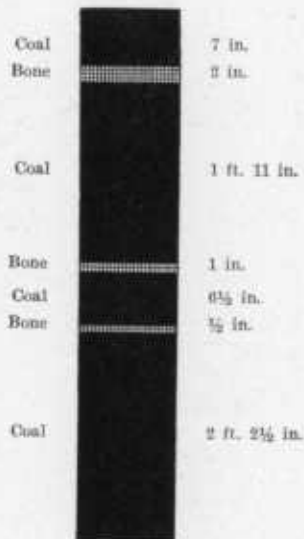

tinue to have, great importance in Maryland by reason of the fact that the Pittsburg coal, or "Big Vein," constitutes a part of the Monongahela formation. These upper beds of the Carboniferous formation were earlier referred to as the Upper Productive Measures and have been the chief source of the coal hitherto mined in Maryland. In addition to the Pittsburg seam there are five other seams of coal, four of which may be regarded as of economic value, and of which three have been from time to time worked. The Monongahela coals cover a much smaller area than the Conemaugh and particularly the Allegheny coals which underlie them. They are, however, much

more accessible as the older coals are deeply buried throughout the central part of the basin.

OPENING OF WITHERS MINING COMPANY, ONE-HALF MILE NORTH OF LITTLE ALLEGANY.

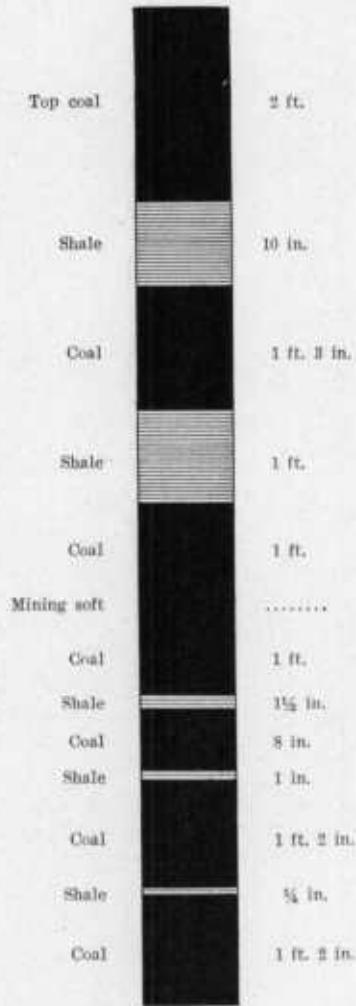

*Pittsburg (Elk garden, "Fourteen-foot" or "Big Vein") coal.*—  
This seam is the most important seam of the Georges Creek valley

at the present time and has been the chief source of the coal in Maryland for more than fifty years. It is restricted almost exclusively to the Georges Creek basin, only one small area having been found in

OPENING OF NEW YORK MINING COMPANY, ONE-HALF MILE EAST OF LITTLE ALLEGANY.

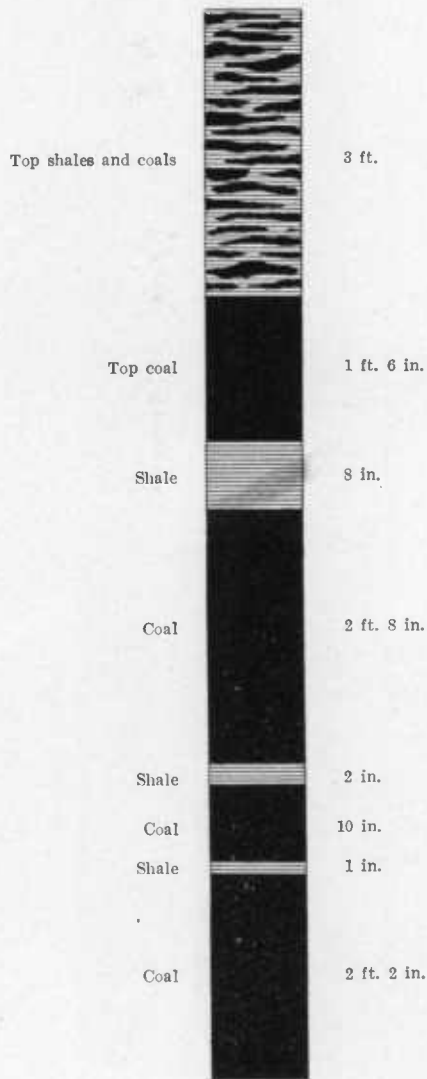

the upper Potomac valley and that long since exhausted. Its position is identical with that of the Pittsburg bed of Pennsylvania and West Virginia, and, as in those states, is found at the base of the Monon-

MINE OF UNION MINING COMPANY, FROSTBURG.

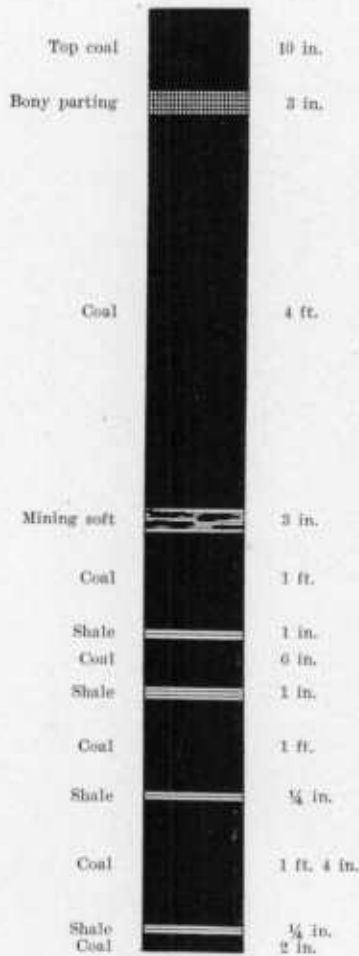

gabela formation. This seam is at the present time being rapidly mined and the time is not far distant when the coal will become entirely exhausted, after which the Maryland coal industry will have

to depend largely upon the smaller veins and especially those of the older formations, on account of their much greater areal extent than

ECKHART MINE, CONSOLIDATION COAL COMPANY, ECKHART MINES.

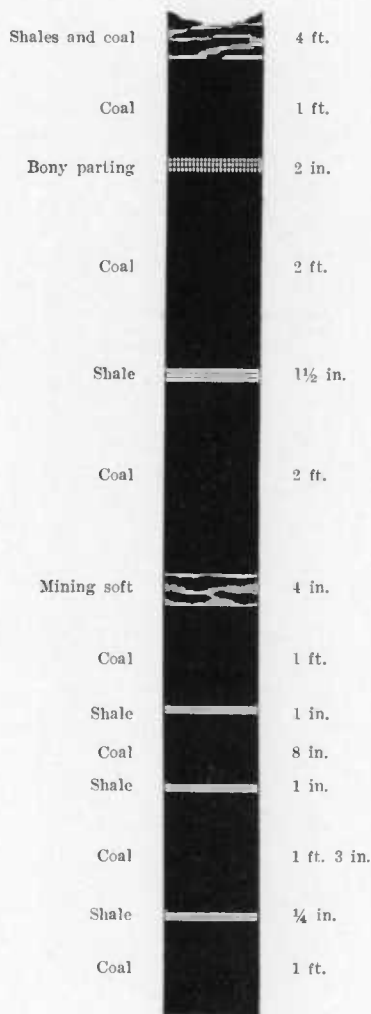

those overlying the "Big Vein." This seam is locally known as the "Fourteen-foot" or "Big Vein" in the Georges Creek valley and



was described under the name of Elkgarden seam in the Piedmont folio of the U. S. Geological Survey, this latter name being originally

HOFFMAN MINE, CONSOLIDATION COAL COMPANY, HOFFMAN.

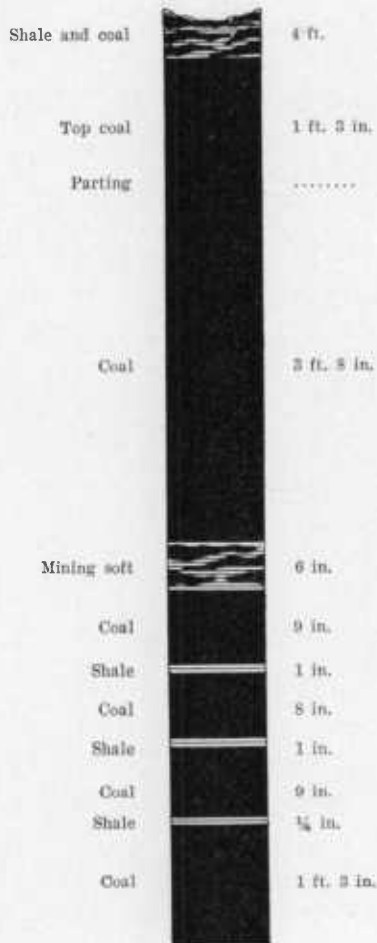

followed in the report on the Geology of Allegany County. As this coal is unquestionably equivalent to the Pittsburg seam of Pennsylvania that name is now adopted since it has priority.

BOWERY MINE, THE BORDEN MINING COMPANY, MIDLOTHIAN.

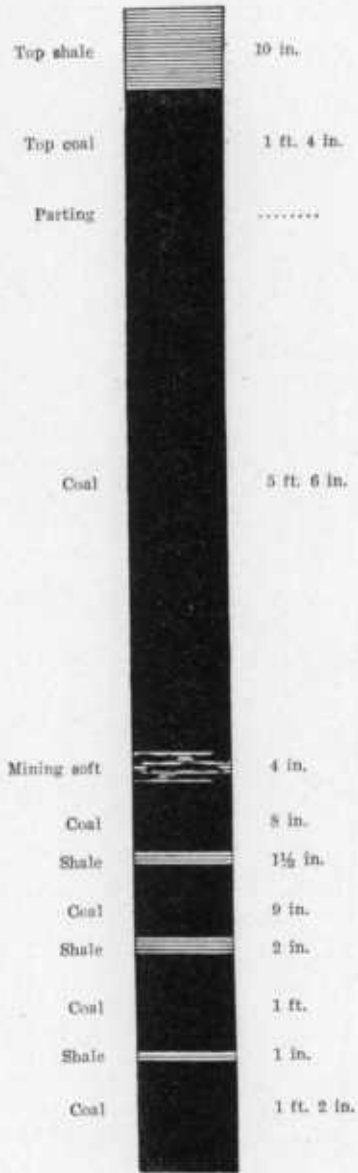

## CARLOS No. 2, BARTON AND GEORGES CREEK VALLEY COAL COMPANY, CARLOS.

Top coal		1 ft. 6 in.
Parting	.....	
Coal		5 ft. 6 in.
Mining soft		3 in.
Coal		1 ft. 3 in.
Shale		1 in.
Coal		4 in.
Shale		½ in.
Coal		10 in.
Shale		¼ in.
Coal		1 ft.

## LIST OF MINES

No.	NAME.	OWNER.	OPERATOR.
1	McGlone & Stafford	Cumberland Basin Coal Co.	Cumberland Basin Coal Co.
2	Trimble	Midland Mining Co.	Midland Mining Co.
3		Frostburg & Withers Mining Co.	Idle.
4	Union No. 2	New York Mining Co.	New York Mining Co.
5	Washington No. 1	Consolidation Coal Co.	Piedmont & Georges Creek Coal Co.
6	Washington No. 2	Chas. Leatham.	" " " " "
7	Pumping Shaft	Consolidation Coal Co.	Consolidation Coal Co.
8	Bowery	Borden Mining Co.	Borden Mining Co.
9	Borden Shaft	" " "	" " "
10	Ocean No. 1	Consolidation Coal Co.	Consolidation Coal Co.
11	Ocean No. 3	" " "	" " "
12	Ocean No. 3½	" " "	" " "
13	Frost	" " "	" " "
14	Ocean No. 2	" " "	" " "
15	Ocean No. 7	" " "	" " "
16	Ocean No. 8	" " "	" " "
17	Enterprise	" " "	" " "
18	Union No. 1	" " "	Midland Mining Co.
19	Borden	Borden Mining Co.	Union Mining Co.
20	Carlos No. 1	Barton & Georges Creek Valley Coal Co.	H. & W. A. Hitchins.
21	Carlos No. 2	Consolidation Coal Co.	Barton & Georges Creek Valley Coal Co.
22	Koontz	New Central Coal Co.	" " " " "
23	Pine Hill or No. 3	Georges Creek Coal and Iron Co.	New Central Coal Co.
24	Columbia or Nos. 9 & 10	" " " " " "	Georges Creek Coal and Iron Co.
25	No. 1 and No. 4	" " " " " "	" " " " "
25a	No. 16	" " " " " "	" " " " "
26	Repold	" " " " " "	Idle.
27	Beadnell	" " " " " "	"
28	Kingsland	Maryland Coal Co.	Maryland Coal Co.
29	Appleton	" " "	" " "
30	Patton	" " "	" " "
31	New Detmold	" " "	" " "
32	Big Vein Hill	Coromandel Coal Co. bo't of N. C. C. Co.	Coromandel Coal Co.
33	Shamrock	Consolidation Coal Co.	Lonaconing Coal Co.
34	Pekin	Atlantic & Georges Creek Consolidated Coal Co.	Idle.
35	Moscow No. 1	Estate of A. B. Shaw.	Moscow-Georges Creek Mining Co.
36	Moscow No. 2	Moscow-Georges Creek Mining Co.	" " " " "
37	Moscow	Piedmont Mining Co.	Piedmont Mining Co.
38	Swanton	Swanton Coal Co.	W. J. Chapman Coal Mining Co.
39	Jackson	American Coal Co.	American Coal Co.
40	Caledonia	" " "	" " "
41	Potomac	Black, Sheridan & Wilson.	Potomac Coal Co.
42	Morrison	Estate of Carrie Morrison.	Frostburg Coal Mining Co.
43	Phoenix & Eckhart	Phoenix & Georges Creek Mining Co.	Phoenix & Georges Creek Mining Co.
44	Penn	Cumberland-Georges Creek Coal Co.	Cumberland-Georges Creek Coal Co.
45	Excelsior	M. P. Gannon.	Idle.
46	Buxton	West Va. Central & Pittsburg R. R. Co.	Davis Coal & Coke Co.
47	Franklin	" " " " " "	Idle.
48	Scrap	" " " " " "	Davis Coal & Coke Co.
49	Buckhorn	" " " " " "	" " " " "
50	Hampshire	" " " " " "	Piedmont-Cumberland Coal Co.
51	Six Foot	Estate of James Morrison.	" " " " "
52	Tacoma	Piedmont & Georges Creek Coal Co.	Piedmont & Georges Creek Coal Co.
53	Phoenix	H. G. Davis & Bro. & J. O. J. Green.	Idle.
54	Bloomington	Empire Coal Co. and Jones and Owens Estates.	Geo. C. Pattison.
55		Georges Creek & Bald Knob Coal Co. bo't of Brailer heirs.	Georges Creek & Bald Knob Coal Co.
56		Braddock Coal Co.	Braddock Coal Co.

NOTE:—Pittsburg Coal shown on Map in Solid Color.

Lower Coals in Shading of same color.

P. 396 B





Mining Properties by B. S. Randolph  
 Geology by G. C. Martin  
 Topography by the Maryland Geological Survey in  
 cooperation with the U. S. Geological Survey

MAP OF THE GEORGES CREEK COAL BASIN SHOWING THE LOCATION OF MINING PROPERTIES  
 AND THE AREAL EXTENT OF THE PITTSBURG ("BIG VEIN") AND LOWER COALS

MARYLAND GEOLOGICAL SURVEY

WM. BULLOCK CLARK, STATE GEOLOGIST

1903

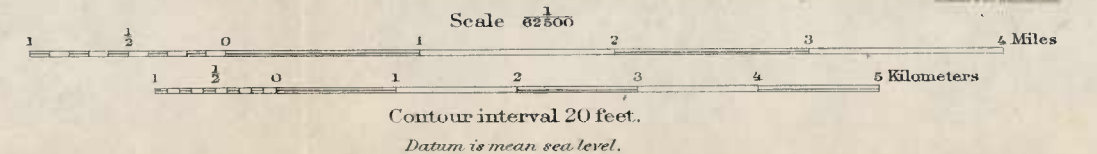

P.386 C



CARLOS No. 1, BARTON AND GEORGES CREEK VALLEY COAL COMPANY, CARLOS.

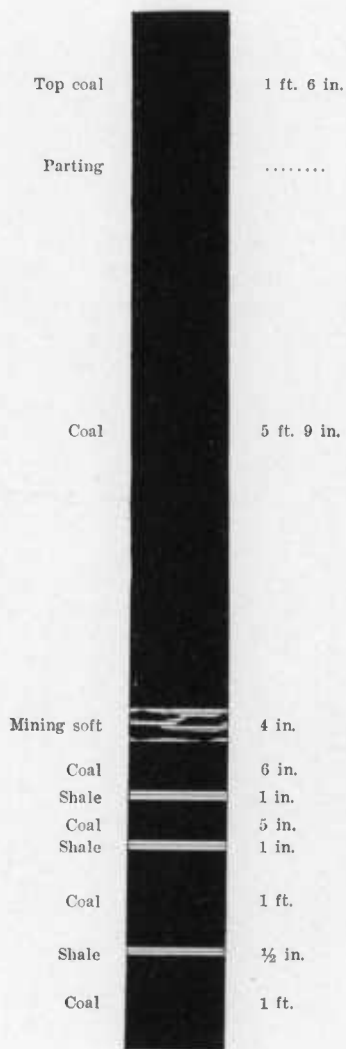

## REPORT ON THE COALS OF MARYLAND

## KOONTZ MINE, NEW CENTRAL COAL COMPANY, KOONTZ.

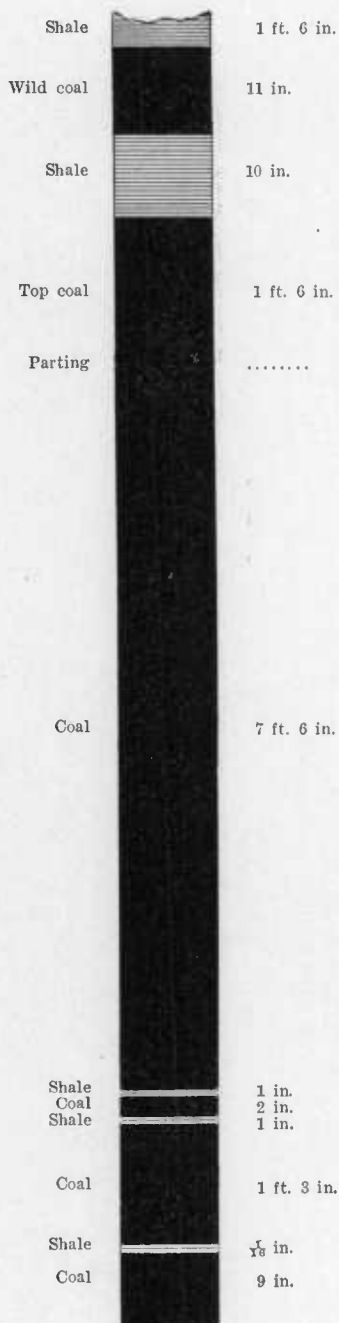

NEW DETMOLD MINE, MARYLAND COAL COMPANY, ONE MILE SOUTHWEST OF LONACONING.

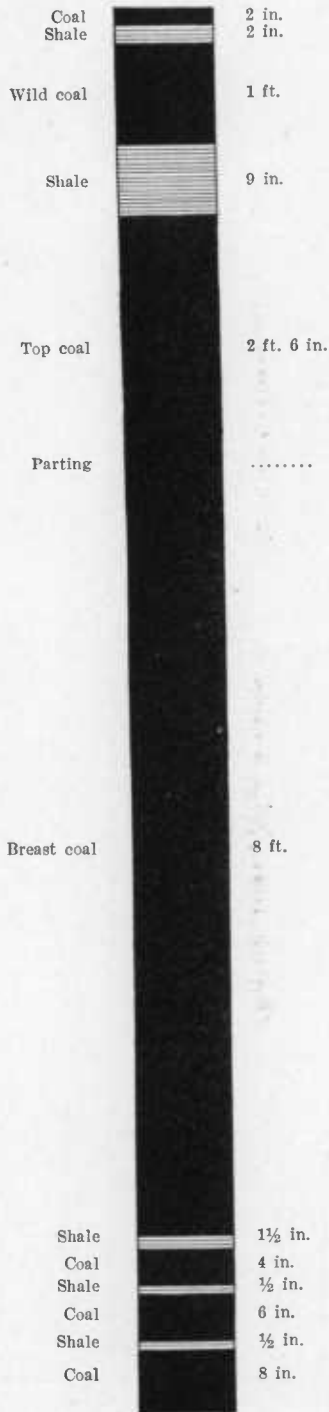



FIRE-COAL MINE ON NORTH SIDE OF PICKELL TRACT, ONE AND ONE-HALF MILES  
NORTHWEST OF MOSCOW.



Coal

8 ft. to 8 ft. 6 in.

JACKSON No. 5, AMERICAN COAL COMPANY, PEKIN.



FIRE-COAL MINE, SOUTH END OF PIKELL TRACT, ONE AND ONE-FOURTH MILES WEST  
OF MOSCOW.

Breast coal



6 ft. 6 in.

CALEDONIA MINE No. 1, AMERICAN COAL COMPANY, THREE-FOURTHS MILE WEST OF BARTON.

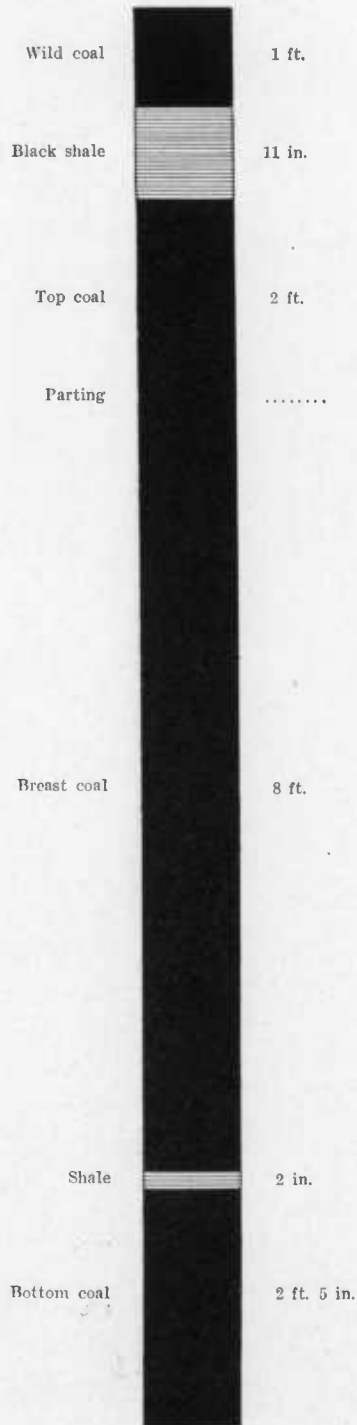

OLD POTOMAC MINE, UNION MINING COMPANY, ONE MILE SOUTHEAST OF BARTON.

Top coal	2 ft. 6 in.
Parting	.....
Breast coal	6 ft. 9 in.
Mining ply	4 in.
Coal	1 ft. 3 in.
Shale	1½ in.
Coal	3 in.
Shale	1½ in.
Coal	1 ft. 4 in.
Sulphur shale	½ in.
Coal	1 ft. 3 in.

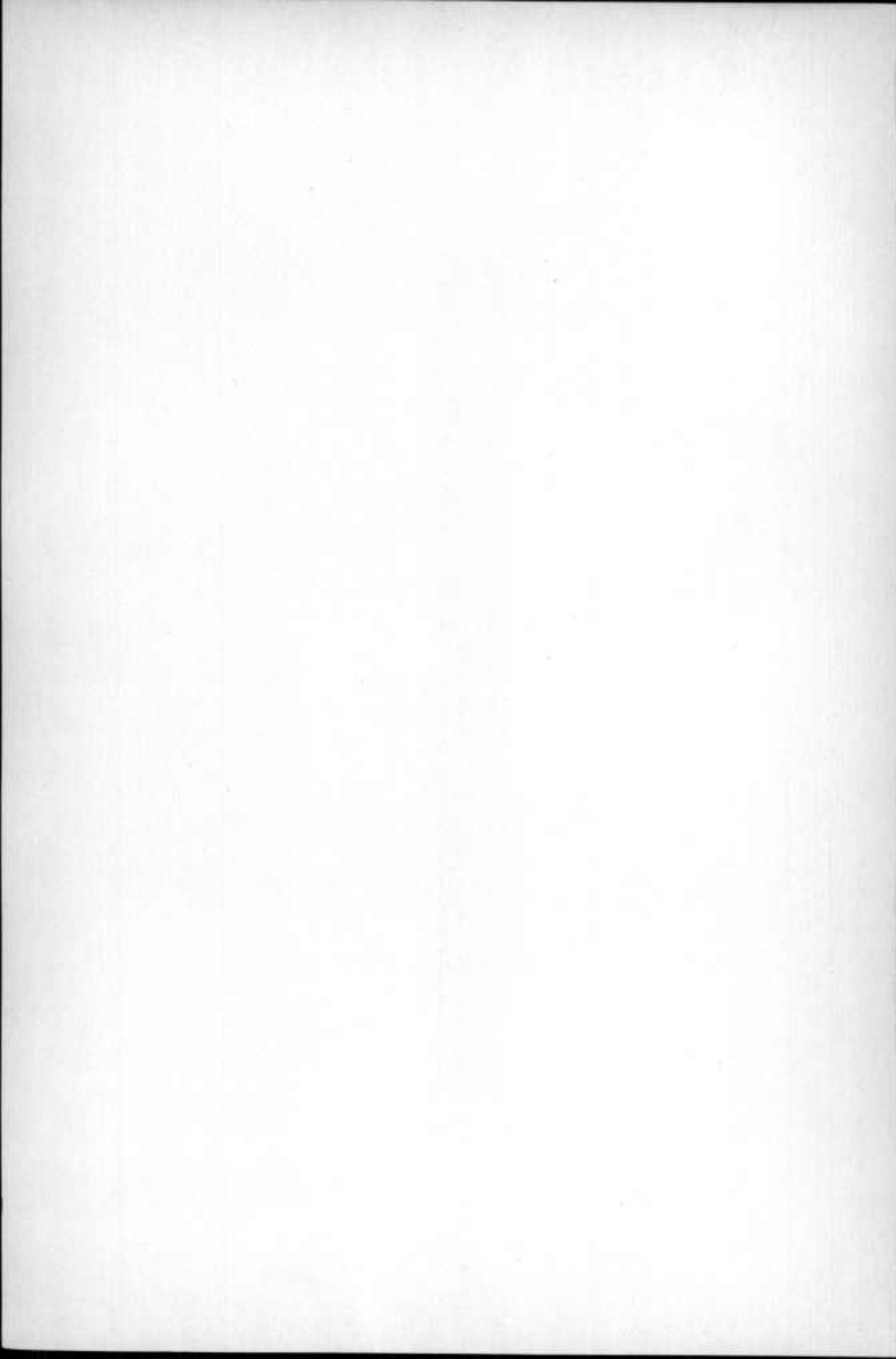

FIG. 1.—PIEDMONT AND GEORGES CREEK COAL COMPANY, WASHINGTON NO. 1.

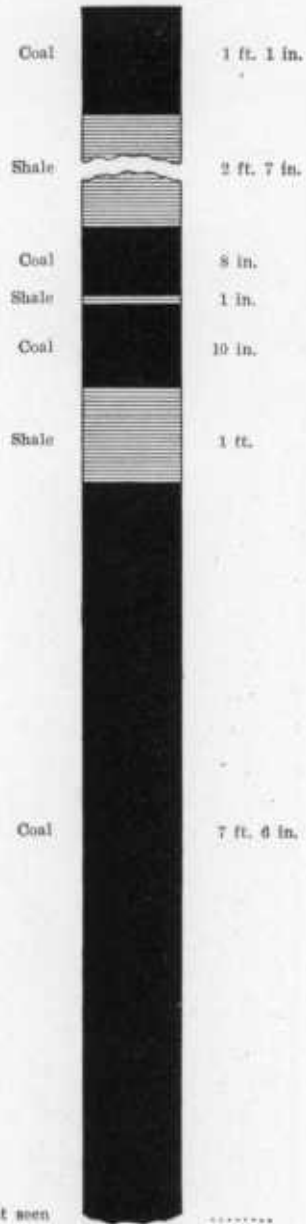

FIG. 2.—BRADDOCK MINING COMPANY.

VIEWS OF COAL MINING PLANTS.



OLD PHOENIX MINE, ONE MILE NORTHWEST OF PHOENIX.





EXCELSIOR MINE No. 2 (OR KNOB), M. P. GANNON, ONE AND THREE-FOURTHS  
MILES NORTHWEST OF FRANKLIN.

Roof coal (not worked)

2 ft. 6 in.

Parting

.....

Breast coal

7 ft. 11 in.

Shale

2 in.

Bottom coal

2 ft. 5 in.



SCRAP NO. 1, DAVIS COAL AND COKE COMPANY, FRANKLIN HILL, ONE AND ONE-FOURTH MILES NORTHWEST OF WESTERNPORT.

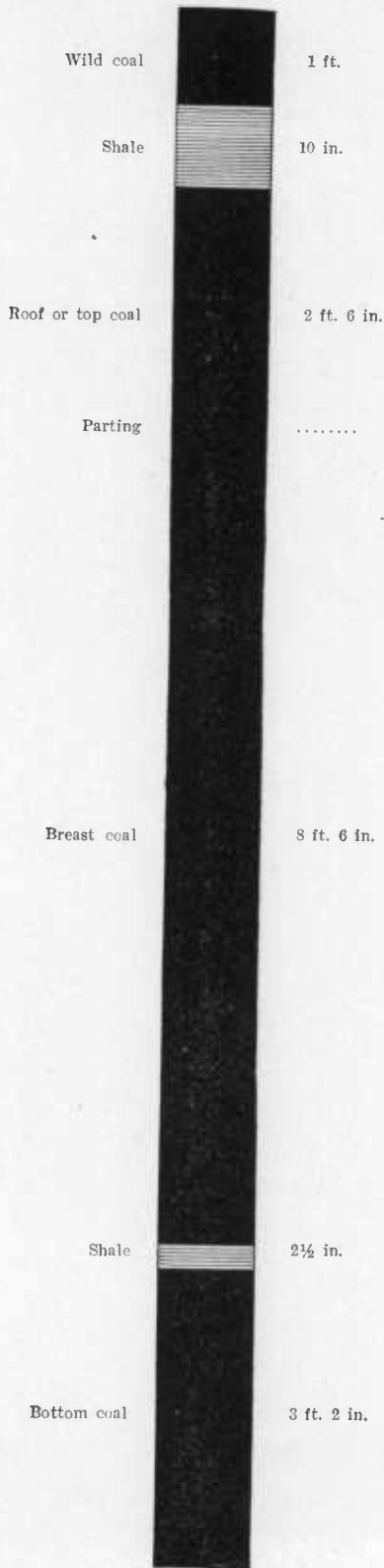

## SCRAP No. 2, DAVIS COAL AND COKE COMPANY, FRANKLIN HILL, ONE AND ONE-FOURTH MILES NORTHWEST OF WESTERNPORT.

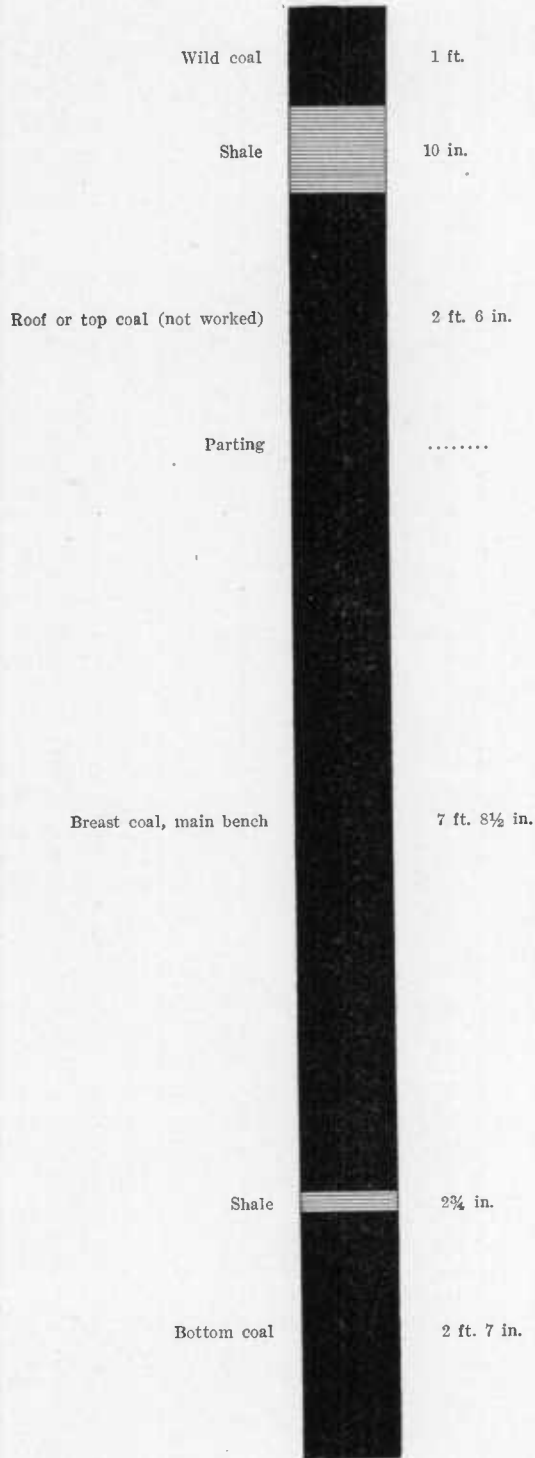

*Redstone coal.*—This seam appears at an interval of from 18 to 40 feet above the Pittsburg coal but is generally so thin and irregular as to have no economic value. Its proximity to the Pittsburg coal would render the seam unworkable even if it were otherwise valuable.

*Section of Redstone Coal.*

GEORGES CREEK AND BALD KNOB COAL COMPANY, ONE AND ONE-FOURTH MILES NORTH OF MOUNT SAVAGE.

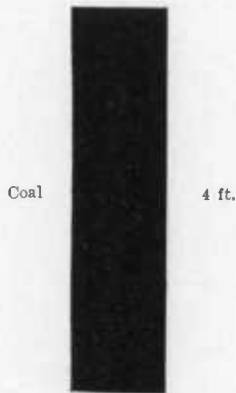

*Lower Sewickley coal.*—This seam occurs at an interval of from 40 to 45 feet above the Redstone coal. It has been cut on the Borden shaft and in the Pumping shaft of the Consolidation Coal Company and also outcrops on the property of the Maryland Coal Company. Its local separation from the Upper Sewickley or Tyson coal has already been described.

*Section of Lower Sewickley Coal.*

MARYLAND COAL COMPANY OPENING ABOVE KINGSLEY MINE, LONACONING.



*Upper Sewickley (Tyson) coal.*—This seam which is locally known as the "Gas coal" occurs at an interval of from 105 to 120 feet above

the Pittsburg and about 45 feet above the Lower Sewickley coal. This coal is very persistent and has considerable economic importance. It is being mined at a number of points at the present time. Like the Pittsburg coal this seam thickens from north to south and has its maximum development in the lower end of the Georges Creek basin.

*Sections of Upper Sewickley Coal.*

MINE ON EASTERN PART OF WITHER'S TRACT, ONE AND ONE-HALF MILES NORTH-EAST OF LITTLE ALLEGHENY.

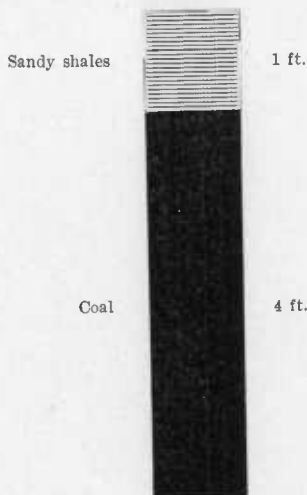

OPENING OF PIEDMONT AND GEORGES CREEK COAL COMPANY, ECKHART.

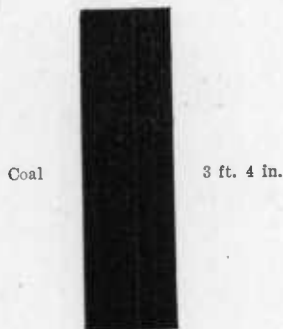

NEW CENTRAL COAL COMPANY, NEAR HEAD OF KOONTZ PLANE, ONE-HALF MILE SOUTH OF KOONTZ.

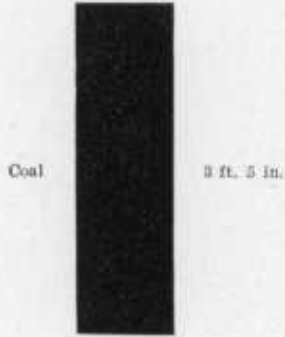

MARYLAND COAL COMPANY, DETMOLD HILL, OPPOSITE KOONTZ MINE, ONE-HALF MILE SOUTH OF KOONTZ.

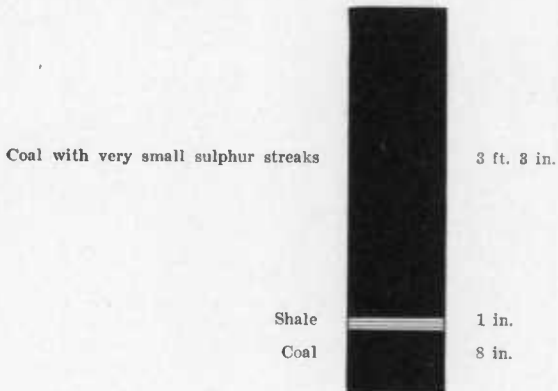

MARYLAND COAL COMPANY ON DETMOLD HILL, NEAR KINGSLEY MINE, ONE-HALF MILE SOUTH OF KOONTZ.

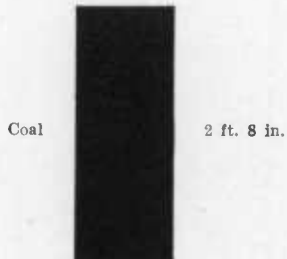

GEORGES CREEK COAL AND IRON COMPANY, ABOVE CEMETERY, ONE MILE NORTH OF LONACONING.

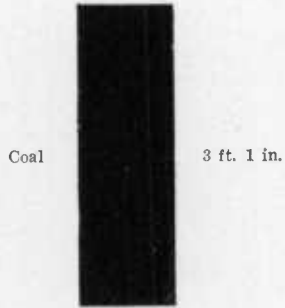

MARYLAND COAL COMPANY, NEAR KINGSLEY MINE, ONE MILE NORTH OF LONACONING.

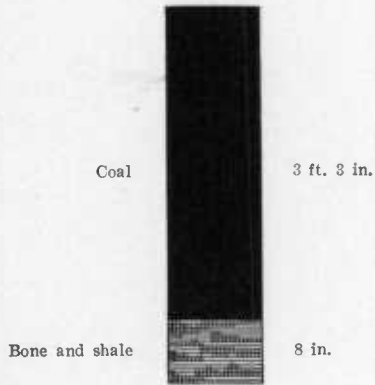

AMERICAN COAL COMPANY, JACKSON HILL, THREE-FOURTHS MILE SOUTH OF LONACONING.

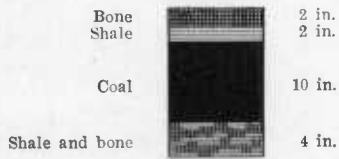

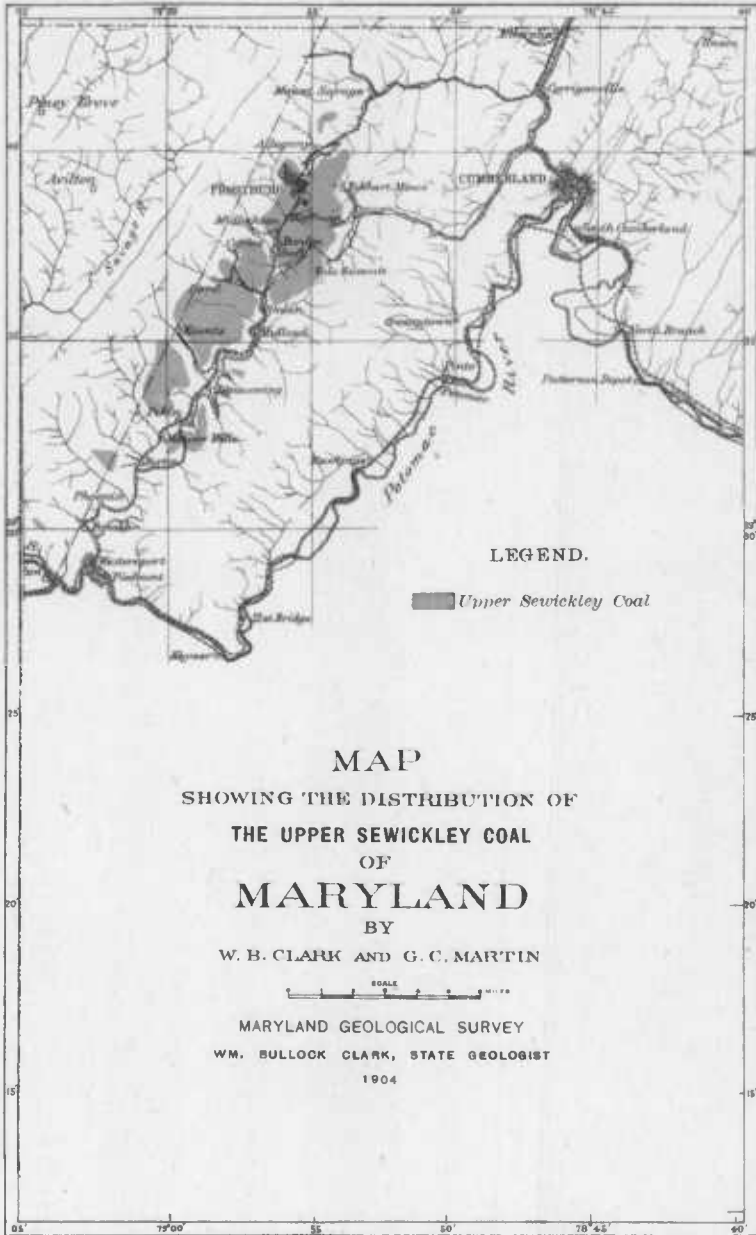

LEGEND.

Upper Sewickley Coal

MAP  
 SHOWING THE DISTRIBUTION OF  
 THE UPPER SEWICKLEY COAL  
 OF  
 MARYLAND

BY  
 W. B. CLARK AND G. C. MARTIN

SCALE  
 1" = 1 MILE

MARYLAND GEOLOGICAL SURVEY  
 WM. BULLOCK CLARK, STATE GEOLOGIST  
 1904



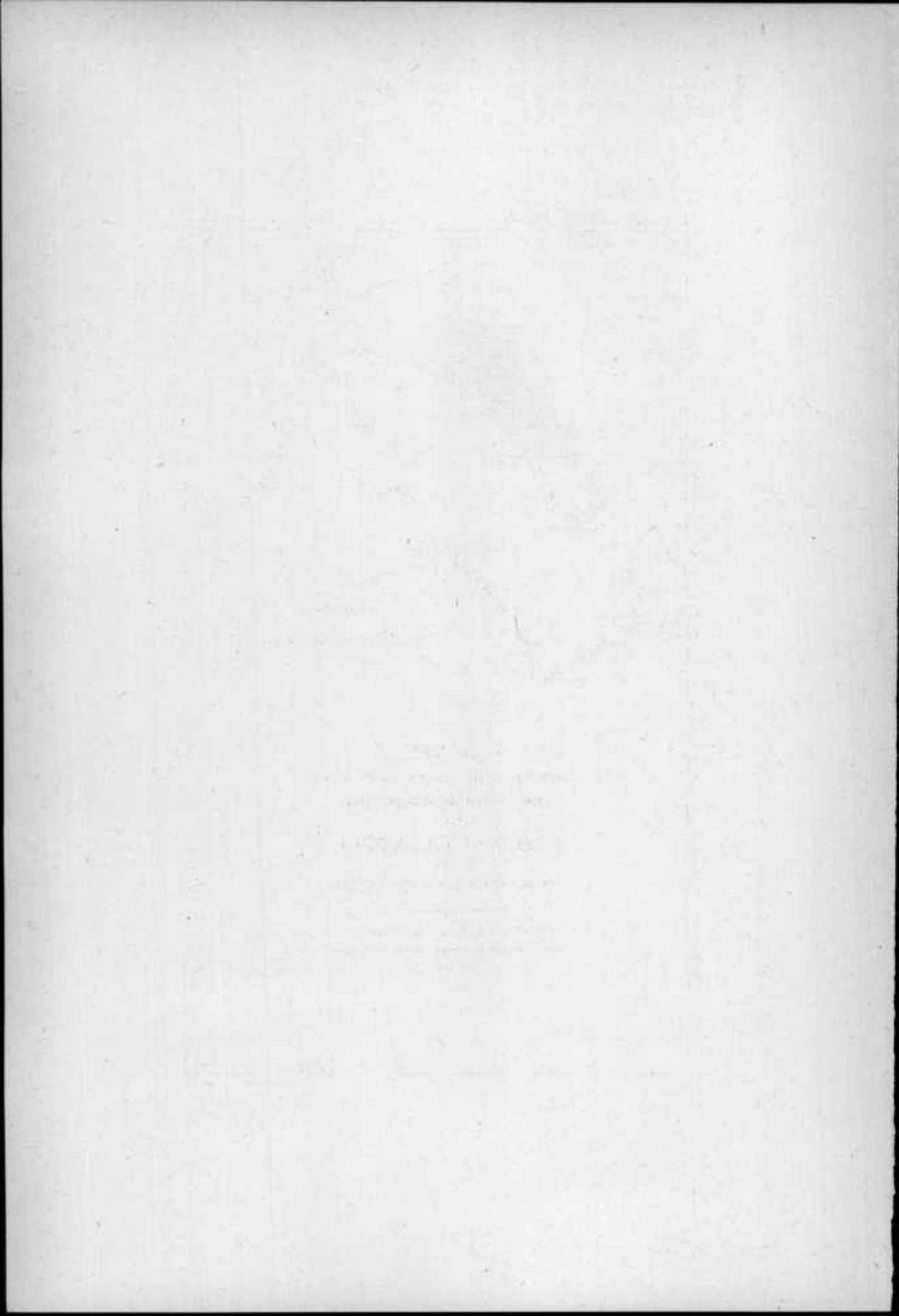

BARTON MINING COMPANY'S MINE AT BARTON.

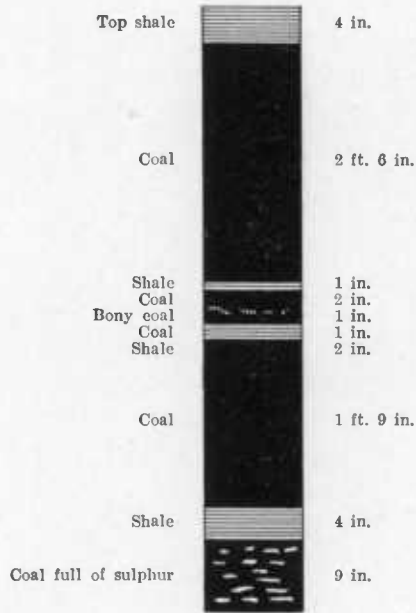

AMERICAN COAL COMPANY'S CALEDONIA MINE, ONE MILE WEST OF BARTON.

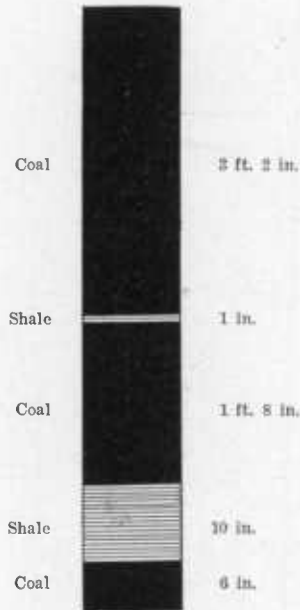

## DAVIS COAL AND COKE COMPANY, FRANKLIN HILL, ONE-HALF MILE SOUTHWEST OF FRANKLIN.

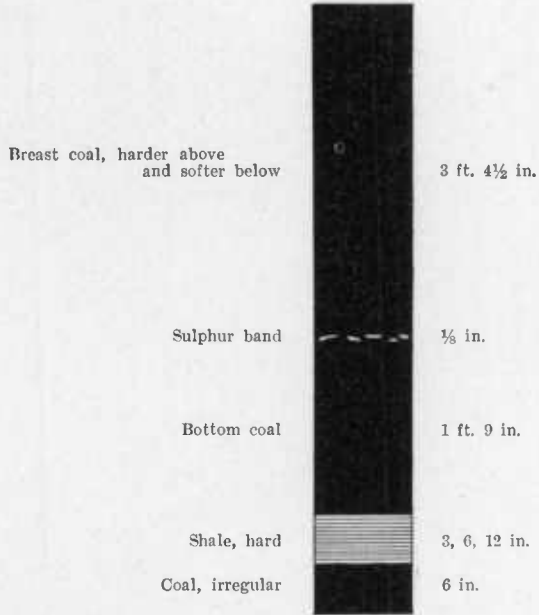

*Uniontown coal.*—This seam is very thin and has been recognized in the Pumping shaft near Frostburg. It is a thin and unimportant seam and probably has at no point sufficient thickness to be of economic value.

## PUMPING SHAFT, CONSOLIDATION COAL COMPANY, FROSTBURG.

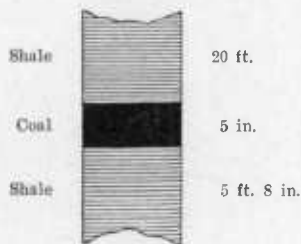

*Waynesburg (Koontz) coal.*—This seam occurs at an interval of from 220 to 240 feet above the Upper Sewickley coal. The area of

outcrop of this coal is small but the vein is persistent and has considerable economic value although it can never be of any great importance on account of the limited amount of coal. This coal is at the top of the Monongahela formation and has been locally known in the Georges Creek valley as the Koontz seam.

*Sections of Waynesburg Coal.*

NEW CENTRAL COAL COMPANY, NEAR HEAD OF KOONTZ MINE PLANE.

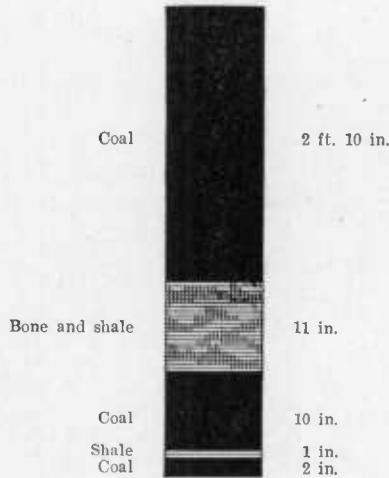

AMERICAN COAL COMPANY, NEAR LONACONING.

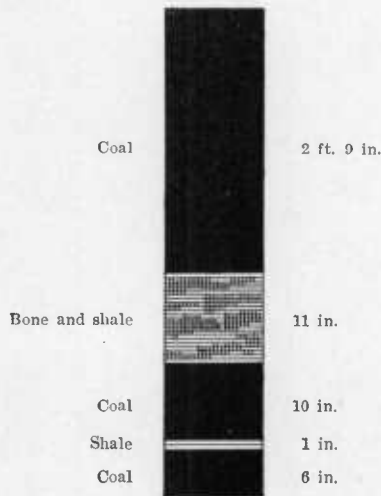

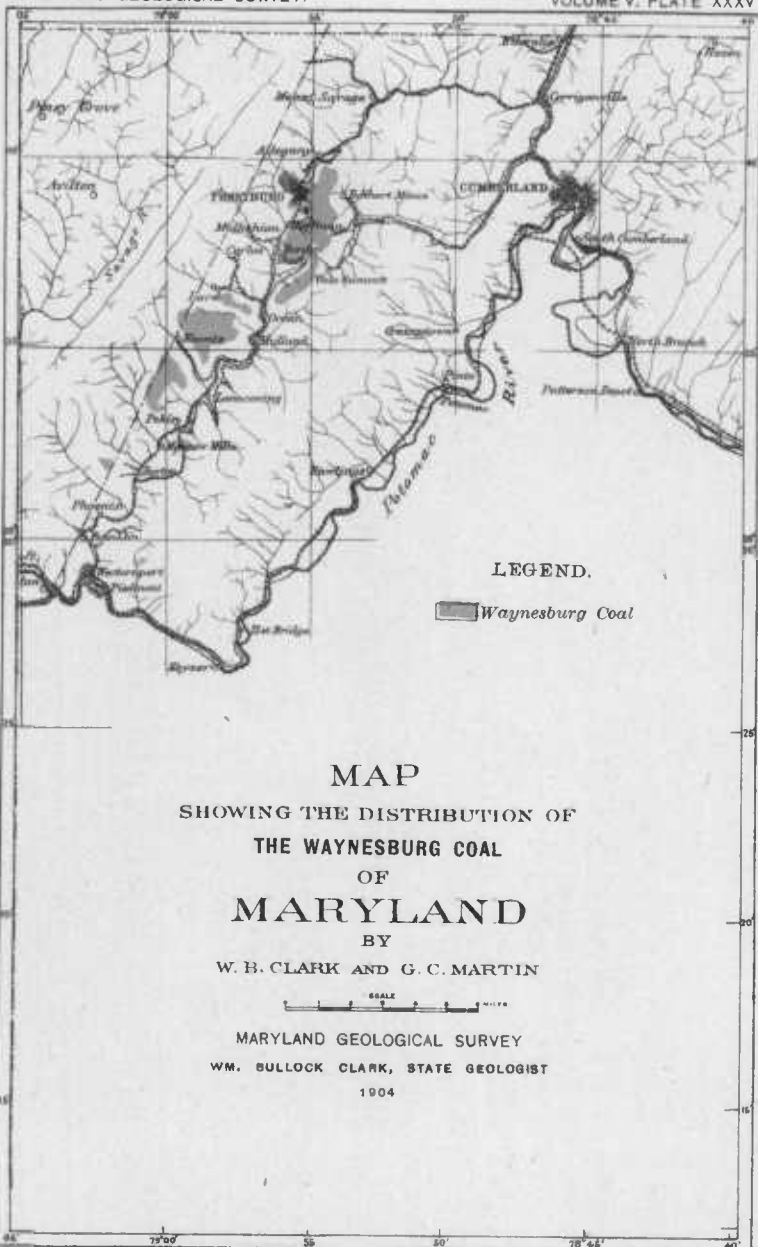

LEGEND.

Waynesburg Coal

MAP  
 SHOWING THE DISTRIBUTION OF  
 THE WAYNESBURG COAL  
 OF  
 MARYLAND

BY  
 W. B. CLARK AND G. C. MARTIN

SCALE

MARYLAND GEOLOGICAL SURVEY  
 WM. BULLOCK CLARK, STATE GEOLOGIST

1904

A. Ross & Co., Lith. Baltimore.

R 906 B

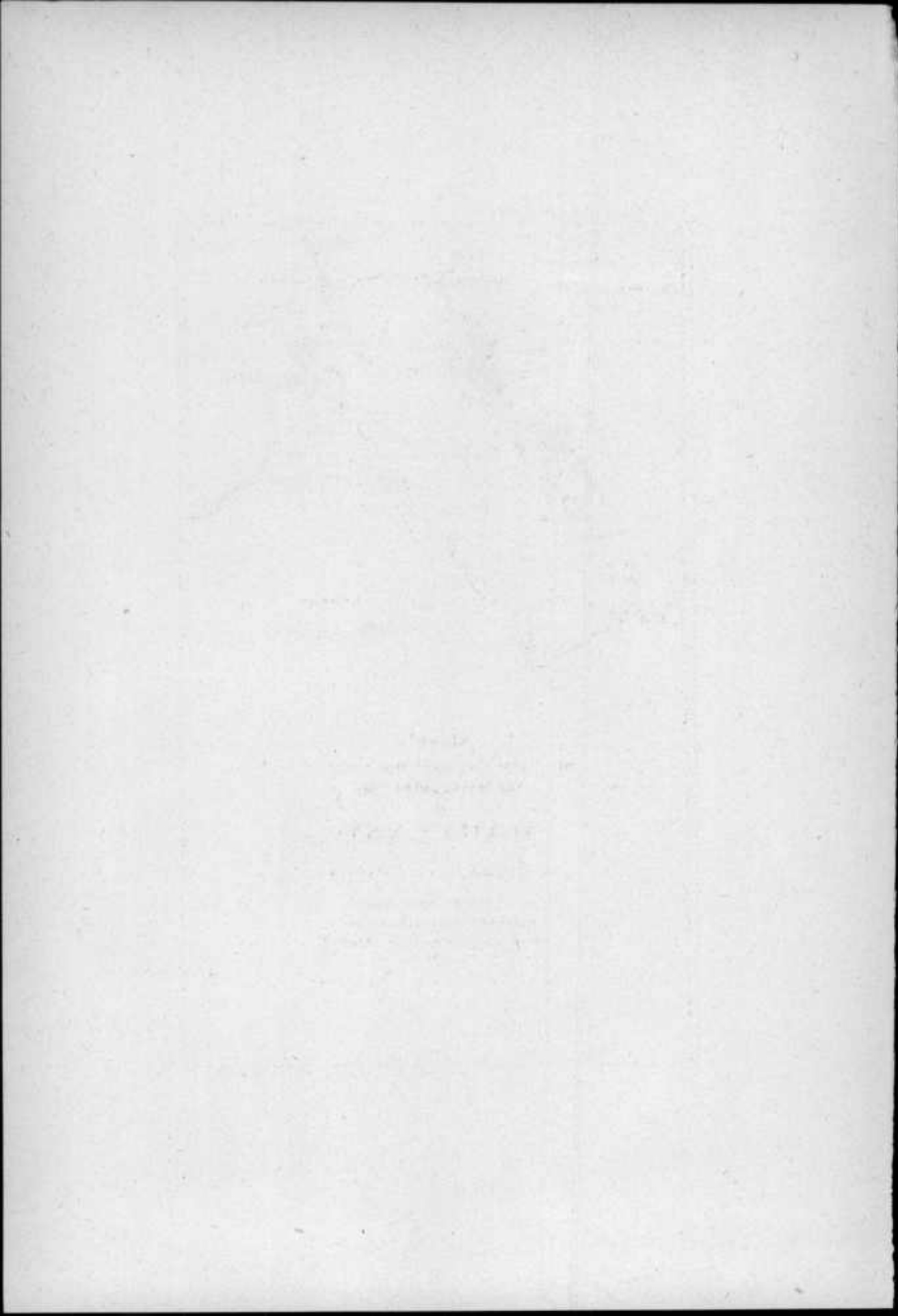

## AMERICAN COAL COMPANY, NEAR LONA CONING.

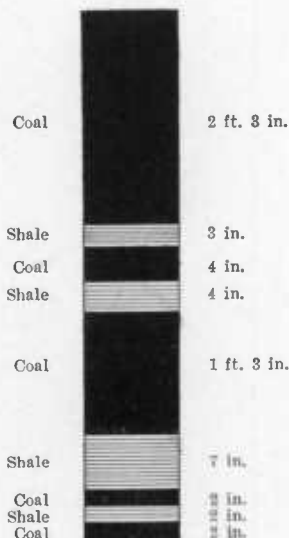

## THE DUNKARD COALS OF THE GEORGES CREEK BASIN.

The Dunkard coals cover so small an area of outcrop and are in general so thin that with the exception of a single seam they have little economic value. These coals are limited entirely to the Georges Creek basin and are found mainly in the central portion of the region. They will probably never be mined to any extent with the exception of the Washington seam and that has not been very fully developed as yet. These upper beds were earlier referred to under the name of the Upper Barren Measures.

*Waynesburg "A" coal.*—This coal, which has a thickness of 2 feet on "Dug Hill" near Lonaconing, possesses no commercial value. It is generally found at from 40 to 45 feet above the Waynesburg coal.

*Washington coal.*—This coal occurs at an interval of about 120 feet above the Waynesburg coal. It has a thickness of between 3 and 4 feet more or less broken up with shale bands but the quality of the coal is not well known. Its small areal extent gives it little economic value.

*Section of Washington Coal.*

SECTION EAST OF PUMPING SHAFT, FROSTBURG.

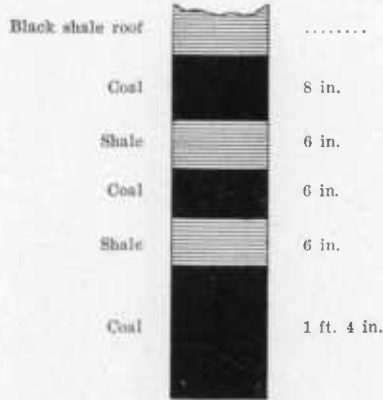

*Jollytown coal.*—This coal occurs in a thin seam of small areal extent and has no commercial value.

THE UPPER POTOMAC BASIN.

The Upper Potomac basin is a syncline which is wider and shallower than the Georges Creek basin. It is a simple syncline from Piedmont to a point near Harrison where the axis forks by the development of a low anticline in the center of the broad basin. Between Piedmont and Harrison the Potomac meanders near, and in general west of, the synclinal axis. Between Harrison and Schell the river flows not far from the western fork of the axis, probably crossing it several times. Above Schell the river seems to be constantly to the east of the western fork of the axis.

The Maryland part of this basin is not deep enough to contain any coal above the Conemaugh formation, except in Fairfax Knob and in the small knob near Shaw where the Pittsburg coal was formerly mined.

The Lower Kittanning coal is of workable thickness and quality throughout the greater part of this basin. Below Stoyer it can all be mined by drift from the Potomac valley.

Above Stoyer it is all shaft coal except along the western outcrop. The dip is not great enough to prevent the coal from being readily



mined in all directions from shafts located anywhere along the line of the railroad. The coal is of exceptional thickness and quality above Gorman.

The Upper Freeport coal can be mined by drift from the center of the Potomac valley as far south as Bayard. Above this point it is all shaft coal except along the western outcrop. Like the Lower Kittanning, it becomes more valuable toward the south.

The Bakerstown coal is drift-coal in its entire area. It improves in quality and thickness toward the north, being most valuable in the region between Blaine and Windom. The Upper Kittanning and Lower Freeport are only locally workable. The former is known to be workable only in the region around Harrison, and the latter in the headwaters of Three-fork Run. Both of these seams are here drift-coal, and are shown by borings to be extremely thin or even absent in the upper part of the Potomac valley where they are below drainage.

#### THE POTTSVILLE COALS OF THE POTOMAC BASIN.

The Pottsville coals are practically unknown in the Potomac basin. Throughout most of the area the Pottsville formation lies below the river level while its outcrop on the mountain sides is obscured. The Pottsville coal seams generally are so thin and unimportant in Maryland that no development work has hitherto been undertaken in the Potomac basin. A few traces of coal below the base of the Allegheny formation have been observed although the so-called Railroad seam mentioned in earlier discussion of the Georges Creek basin and referred in part to the Pottsville coal seams has been referred by Dr. I. C. White in his West Virginia coal report,<sup>1</sup> to the Mercer Group and thus to the horizon of the Mt. Savage coal. It is probable, however, that most if not all of the Railroad seam above Piedmont should be regarded as the equivalent of the Clarion seam and therefore to be referred to the later or Allegheny formation.

It is not probable that any of these Pottsville coals, if ever pros-

<sup>1</sup> West Virginia Geol. Survey, vol. ii, 1903, p. 626.

pected, will be found to have any economic value. They are probably thin, unimportant beds and as in the Georges Creek basin may almost if not entirely disappear.

#### THE ALLEGHENY COALS OF THE POTOMAC BASIN.

The Allegheny coal seams are the most important of the coal beds of the Potomac basin. Several seams are found of workable thickness, two in particular being widespread and of increasing importance in proceeding up the valley. They reach their maximum development near the southern end of Garrett county where they are already the source of a large coal output at Henry on the West Virginia bank of the river. Prospect openings and bore-holes show that a large territory extending along the southern slopes of Big Backbone Mountain as far as the valley of the North Branch of the Potomac and beyond into West Virginia is underlain by coals of the Allegheny formation. As the overlying formations have been largely removed by erosion these coals can be readily reached by drifts or shallow shafts throughout the central part of the valley. They are thus much more accessible to railroad transportation over a large part of the area than in the Georges Creek basin where their greater thickness assures their earlier development. They will in the near future become next to the Pittsburg seam of the Georges Creek valley the chief source of supply for this region.

*Brookville (Bluebaugh) coal.*—The Brookville seam which is so important in the upper part of the Georges Creek basin but which has largely disappeared before the lower part of that area is reached is practically undeveloped in the Potomac basin. It is not probable that it will be found at any point of sufficient thickness to have commercial value.

*Clarion coal.*—The Clarion coal occurs at from 15 to 30 feet above the base of the Allegheny formation. It contains between 2 and 4 feet of coal in the Potomac basin although the various benches are frequently separated by partings of bone and shale. The Clarion coal of the Potomac basin has often been confused with the Pottsville

coals. In the northern part of the basin this coal is locally known as the "Railroad" seam since it is frequently exposed in the railroad cuttings.

*Sections of Clarion Coal.*

PROSPECT ON NORTH BANK OF LAUREL RUN, ONE-HALF MILE WEST OF EMPIRE.

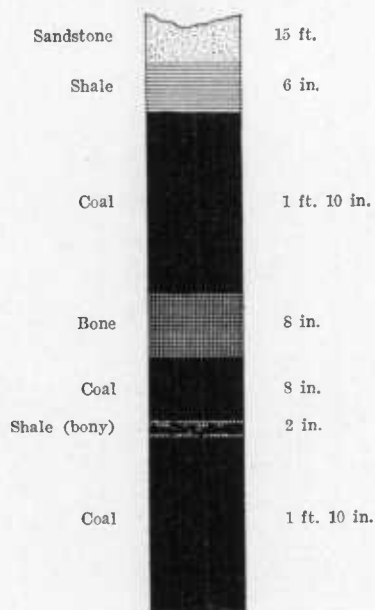

CUT ON W. VA. C. R. R. JUST BELOW WARNICK'S.

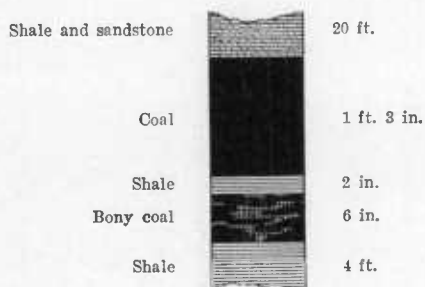

OPENING BELOW LOWER FORK OF THREE-FORK CREEK, ONE MILE WEST OF CHAFFEE.

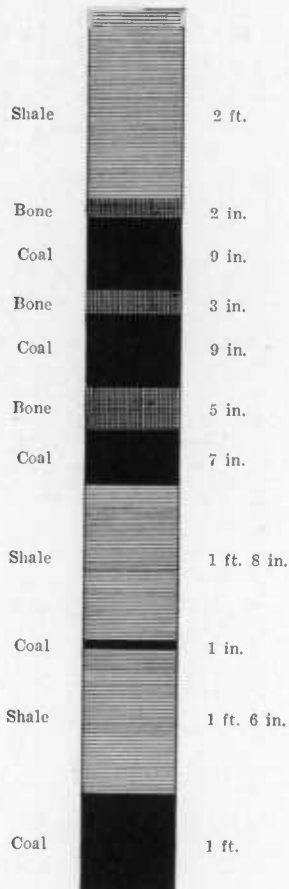

TWO HUNDRED YARDS NORTH OF STATION AT CHAFFEE.

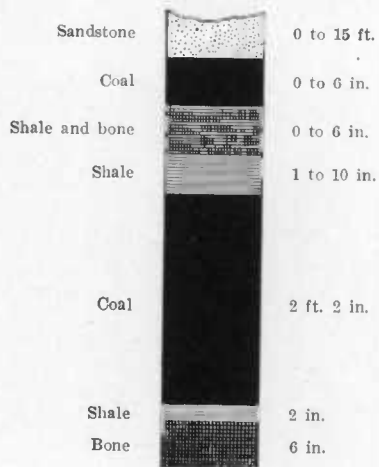

SECTION ON FAHEY'S PLANE NEAR BLAINE.

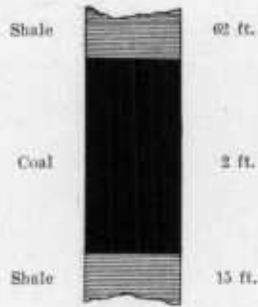

EAST OF HARRISON.

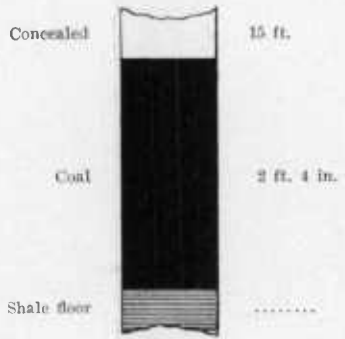

CUT ON B. & O. R. R. ABOVE BLACK BEAR MINE.

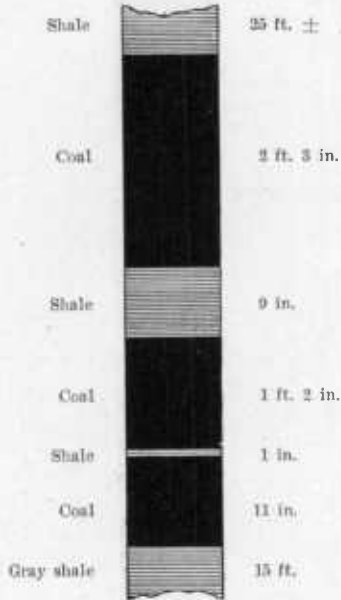

*Lower (and Middle) Kittanning (Davis or "Six-foot") coal.*— This seam is the most important in the Potomac basin. It covers a large part of the region especially in the southern part of the valley where it underlies the entire area. As in the Georges Creek valley, this coal is often separated into two quite distinct seams by a shale

*Sections of Lower and Middle Kittanning Coal.*

PROSPECT THREE-FOURTHS MILE WEST OF WINDOM.

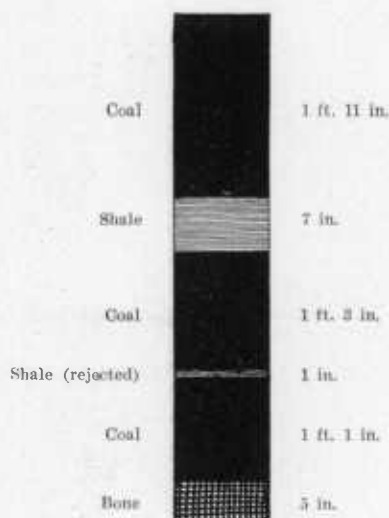

parting that may at times reach several feet in thickness. It is probable, therefore, that this seam is the equivalent of the Lower and Middle Kittanning of Pennsylvania. This coal occurs from 90 to 150 feet above the base of the formation and from 170 to 210 feet below the top. It is at times considerably broken up by shale and bone partings although generally one or more benches consist of clean high-grade coal of workable thickness. The entire seam varies from 4 to 6 feet in thickness, which in the southern end of the basin

may at times reach nearly 8 feet in thickness. It is much less squeezed in the southern part of the area than in the northern, the so-called "faults" earlier described in the case of this seam in the Georges Creek basin being much less frequent. This coal is known throughout most of the basin as the Davis seam from Davis, West

BELOW WINDOM, EAST SIDE OF RIVER.

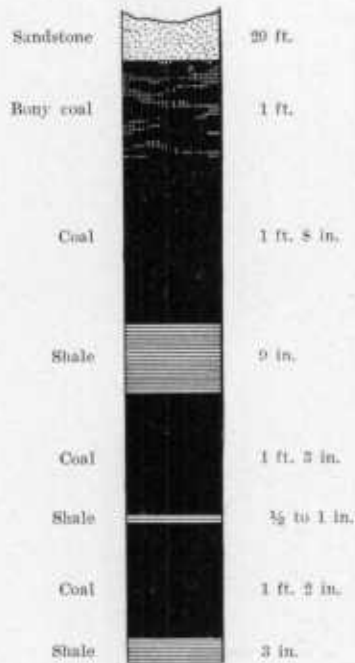

Virginia, where it was first worked extensively by the Davis Coal and Coke Company. In the vicinity of Piedmont, West Virginia, it has been more frequently referred to under the name of the "Six-foot" seam.

BARNUM MINE, ONE-HALF MILE SOUTHWEST OF BARNUM.

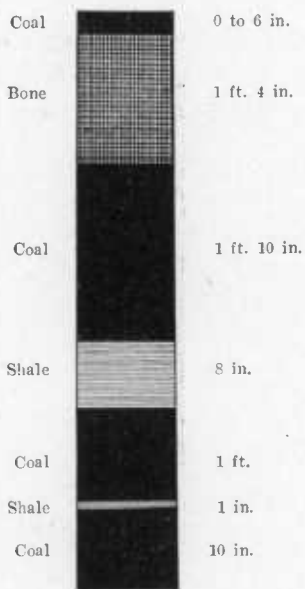

BARNUM MINE, FURTHER IN, ONE-HALF MILE SOUTHWEST OF BARNUM.

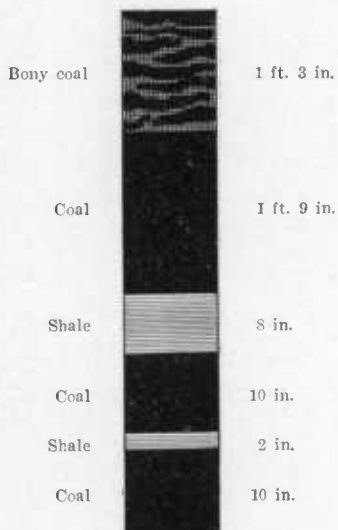



OPENING ON ELKCLICK RUN, ONE MILE EAST OF MT. ZION CHURCH.

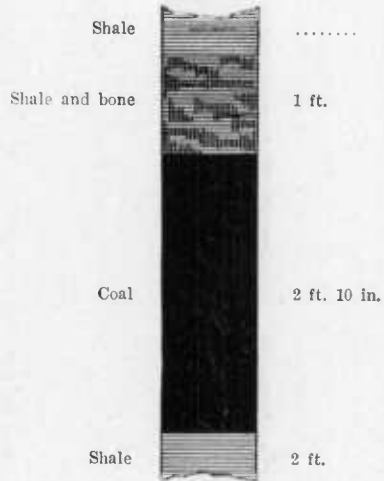

SMALL OPENING ON MARYLAND SIDE OF RIVER, ONE-HALF MILE ABOVE SHAW.

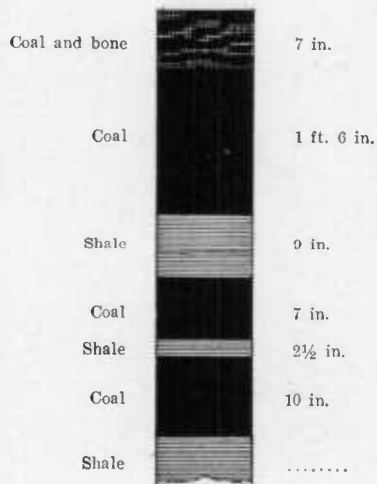

UPPER OPENING ON SOUTH FORK OF THREE-FORK CREEK, ONE AND ONE-HALF MILES WEST OF CHAFFEE.

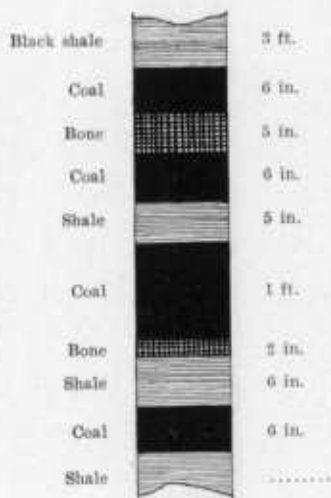

HAMIL'S LOWER OPENING, THREE-FOURTHS MILE NORTH OF BLAINE.

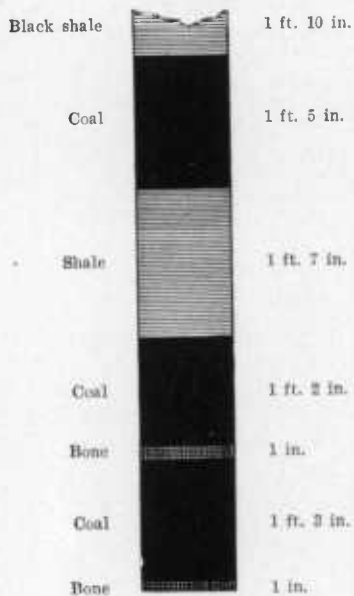

KITZMILER MINE, NEAR BLAINE.

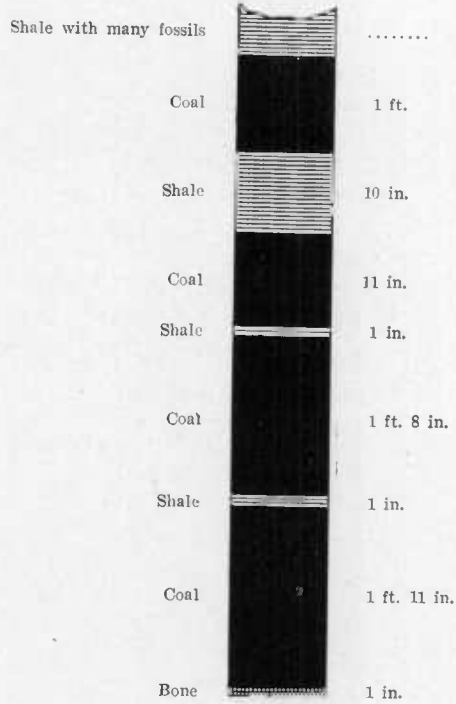

BLAINE COAL COMPANY, ONE AND ONE-FOURTH MILES WEST OF BLAINE.

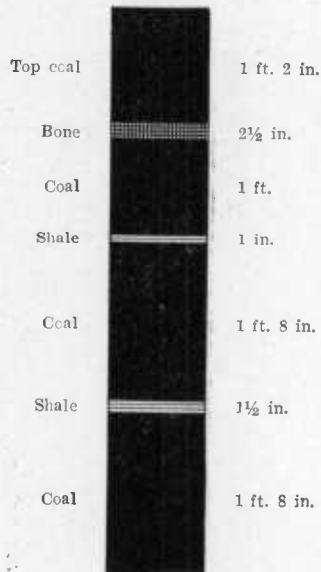

FAHEY'S MINE, ONE AND ONE-HALF MILES SOUTHWEST OF BLAINE.

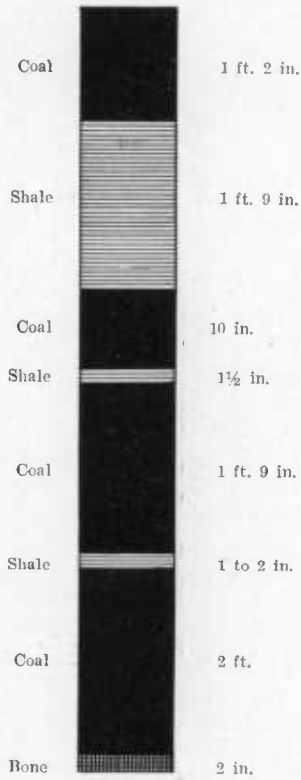

R. A. SMITH'S MINE, ONE-HALF MILE SOUTHWEST OF BLAINE.

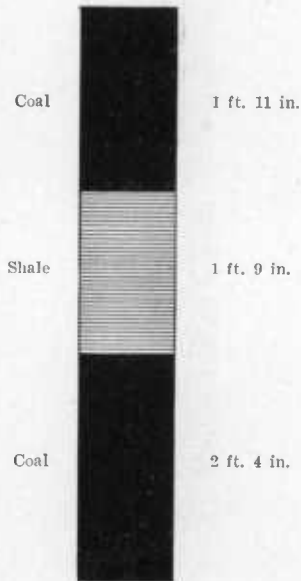

NORTH FORK OF LOSTLAND RUN, THREE AND ONE-FOURTH MILES WEST OF  
HARRISON.

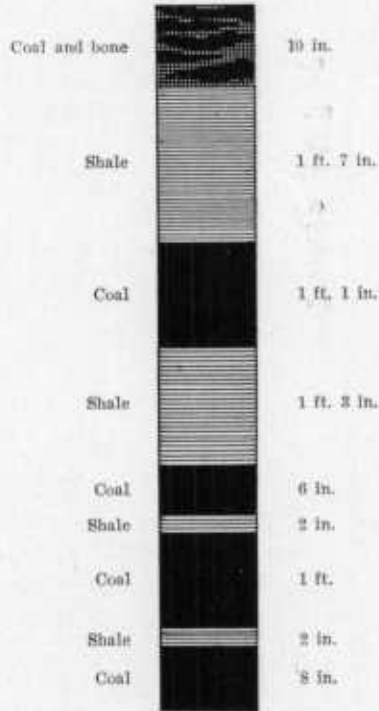

MINE ON SOUTH FORK OF LOSTLAND RUN, ONE AND THREE-FOURTHS MILES NORTH-EAST OF TASKER CORNER.

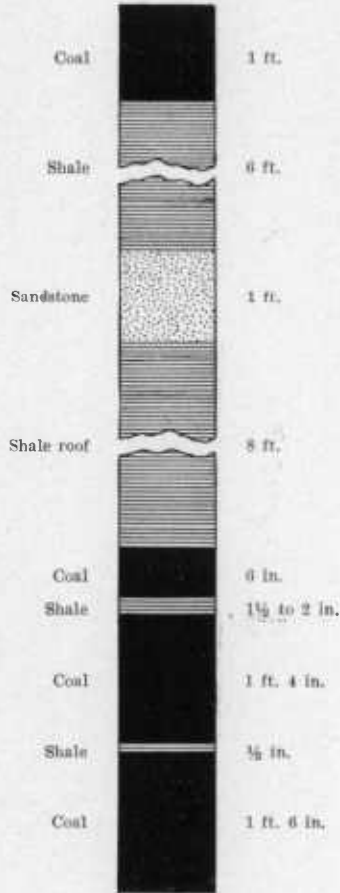

REPORT ON THE COALS OF MARYLAND

MINE ON OLD TRAM ABOVE HARRISON.

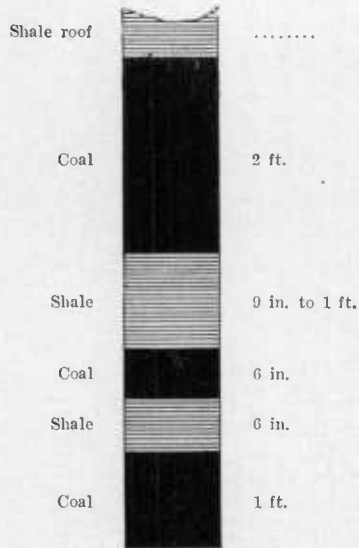

PROSPECT ON HILL ABOVE SCHELL.

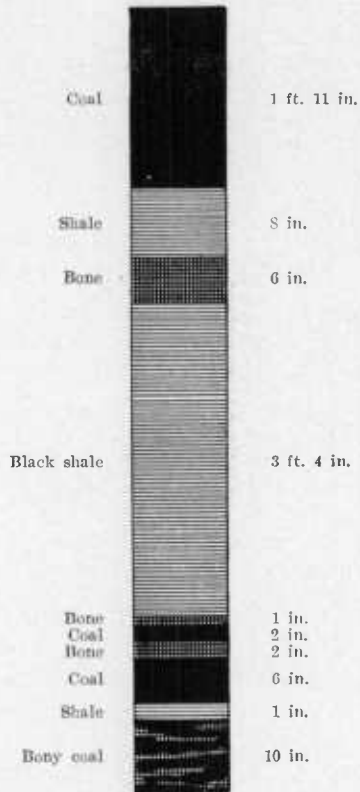

CLARK'S OPENING, ABOVE WITMER'S TRAMROAD, WEST VIRGINIA SIDE OF RIVER,  
OPPOSITE WALLMAN.

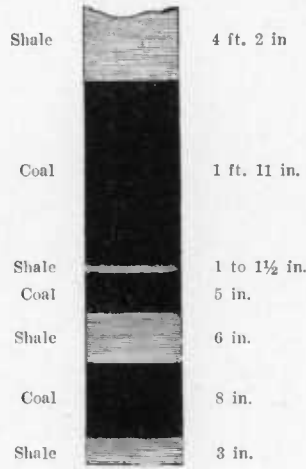

OPENING UP CREEK, ONE-HALF MILE NORTH OF STOYER.

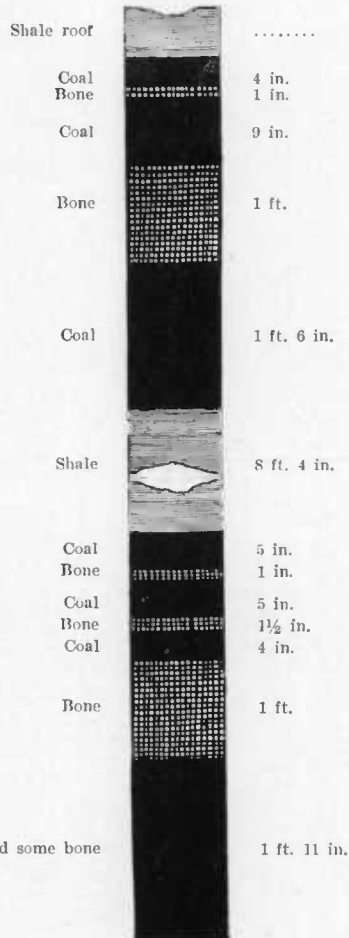



W. H. COSNER'S OPENING, NORTH FORK OF SAND RUN, TWO AND ONE-HALF MILES  
NORTHWEST OF WILSON.

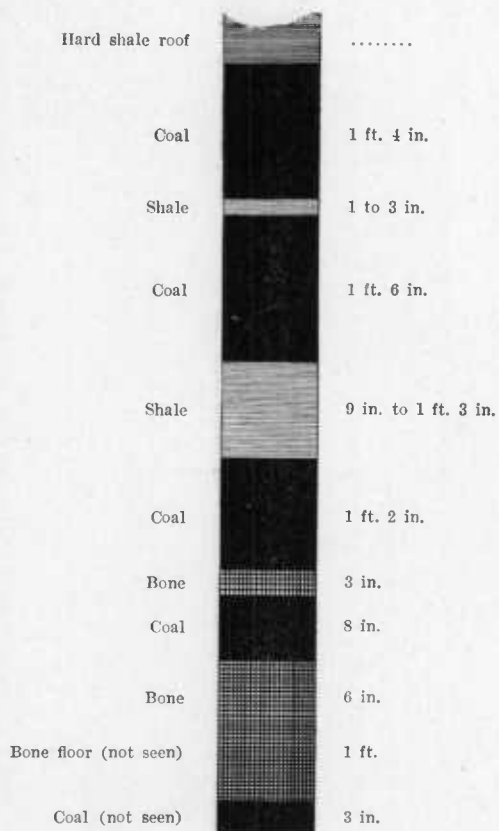

WASHINGTON ARNOLD'S MINE, ON NORTH FORK OF LAUREL RUN, TWO AND ONE-FOURTH MILES NORTHWEST OF DOBBIN.

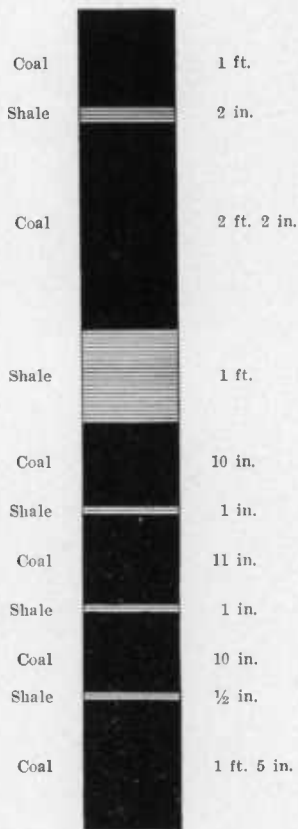

MINE OWNED BY DAVIS COAL AND COKE COMPANY, SOUTH FORK OF LAUREL RUN,  
ONE AND ONE-FOURTH MILES NORTHWEST OF BEECHWOOD.

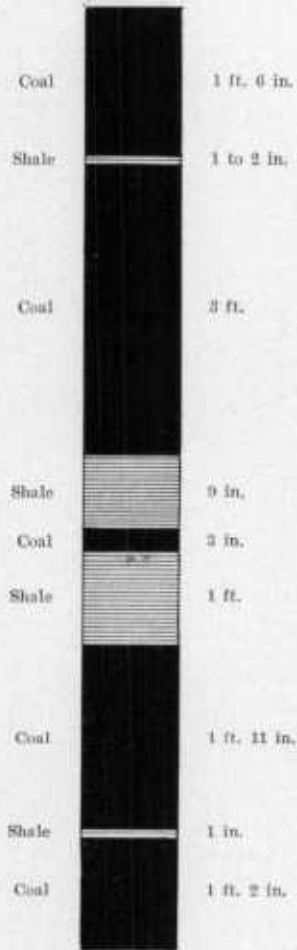

SECTION IN SHAFT (DAVIS SEAM), DAVIS COAL AND COKE COMPANY, HENRY.

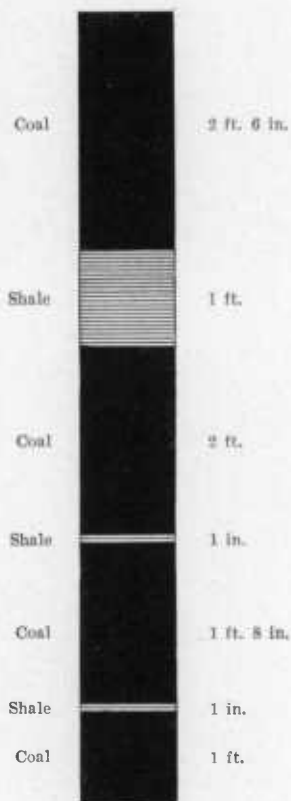

## EAST OF SHAFT (DAVIS SEAM), DAVIS COAL AND COKE COMPANY, THOMAS.

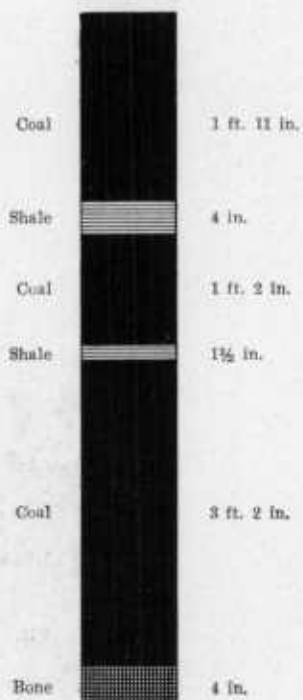

ROOM OFF SIX-FOOT TUNNEL, DAVIS SEAM, SHAFT AT THOMAS.

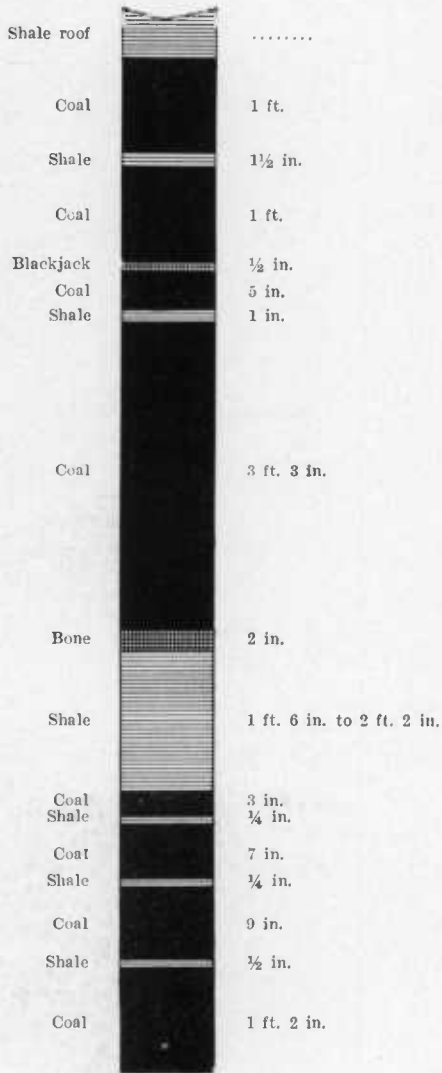

*Upper Kittanning coal.*—This seam occurs from 35 to 65 feet above the top of the Lower Kittanning coal in the Potomac basin where it has been found to reach a thickness of between 3 and 4 feet of clean

coal. It has not been opened at many points and its extent in the basin cannot be definitely determined. It is probable, however, that it is much less persistent than either the Lower Kittanning or Upper Freeport seams as it is apparently absent or unimportant at many points.

*Section of Upper Kittanning Coal.*

TASKER'S MINE, ONE AND ONE-HALF MILES SOUTHEAST OF SWANTON.

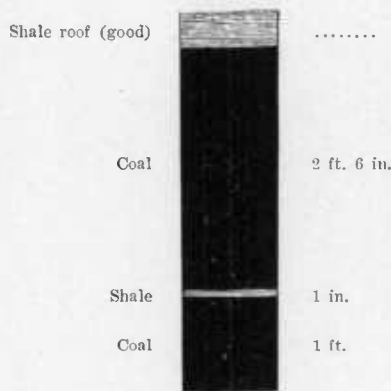

ANOTHER OPENING ON HILLSIDE, ONE-HALF MILE SOUTH OF HARRISON.

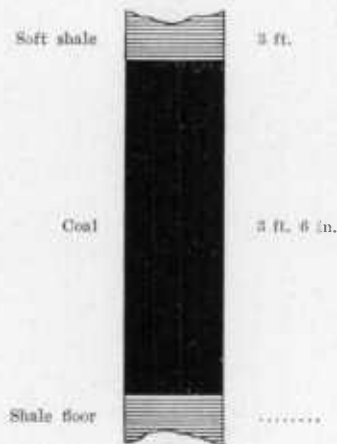

*Lower Freeport coal.*—The Lower Freeport coal is a thin and unimportant seam in the Potomac basin and elsewhere within the State. It occurs at an interval of 55 to 80 feet above the Upper Kittanning and from 100 to 140 feet above the Lower Kittanning coal and is commonly found from 35 to 60 feet below the top of the Allegheny formation. This seam probably will not be found to occur with sufficient thickness to possess any commercial value and is much less persistent in occurrence and uniform in character than the other seams of this basin.

*Sections of Upper Freeport Coal.*

FIRE-COAL MINE, THREE-FOURTHS MILE SOUTHWEST OF BARNUM.

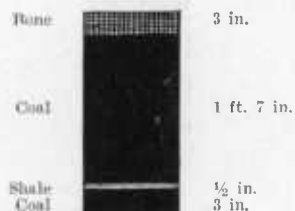

TANKER'S, ON RIVER FRONT, ONE MILE NORTH OF CHAFFEE.

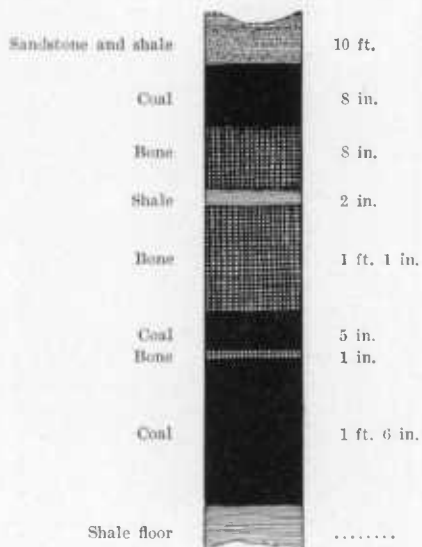



*Upper Freeport (Thomas or "Three-foot") coal.*—This seam caps the Allegheny formation and is found at an interval of from 165 to 210 feet above the Lower Kittanning coal. This seam is known

HAMIL'S MINE, ONE MILE NORTHEAST OF BLAINE.

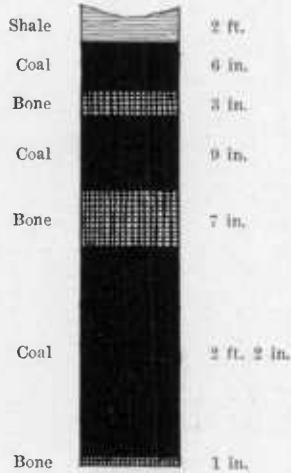

HAMIL'S OPENING, THREE-FOURTHS MILE NORTHWEST OF BLAINE.

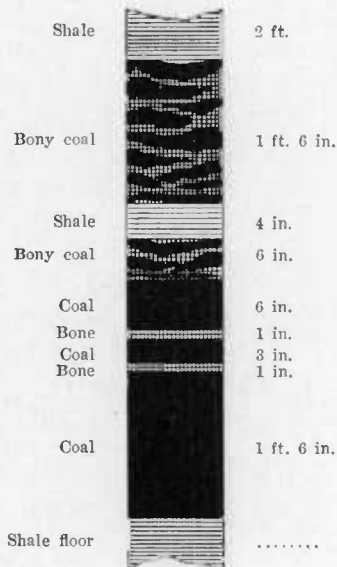

locally as the Thomas or "Three-foot" coal. It is the upper vein at Thomas, West Virginia, where it has been extensively mined by the Davis Coal and Coke Company. It is a very persistent seam

SMALL OPENING UP OLD ROAD TO WEST FROM FOREGOING.

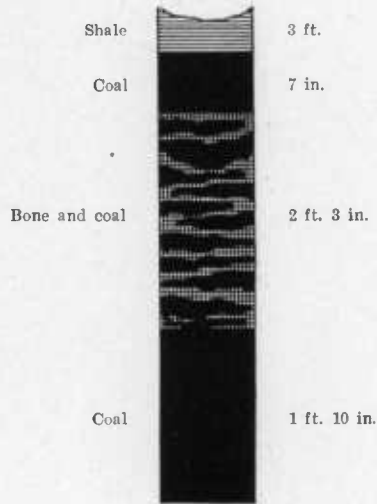

R. A. SMITH'S MINE, ONE-HALF MILE SOUTHWEST OF BLAINE.

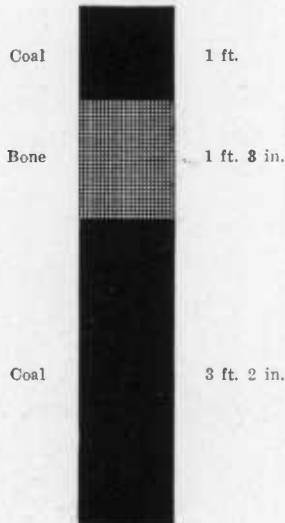

and commonly contains from 2 to 4 feet of good coal but may at times exceed 5 feet in thickness especially in the southern part of the Po-

MINE BETWEEN ELKGARDEN AND BLAINE.

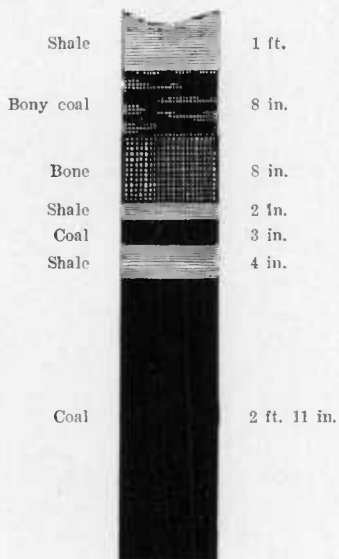

OPENING ONE-HALF MILE SOUTH OF HARRISON.

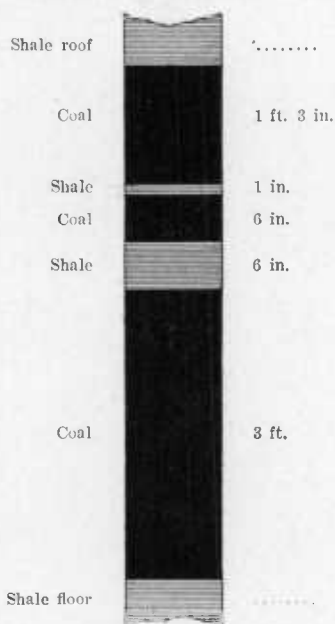

tomac basin where it may at times be worked from the same shaft as the Lower Kittanning coal, as at Henry.

JOS. O'HAYER'S MINE ON TROUT RUN, TWO MILES NORTHWEST OF SCHELL.

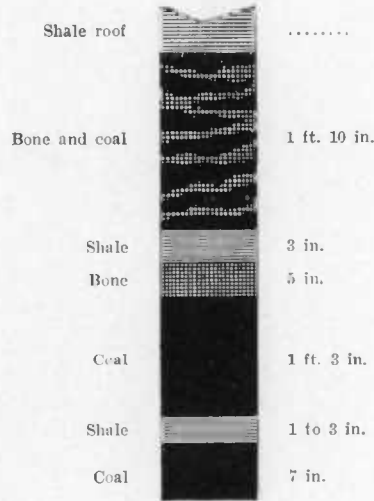

BENJAMIN HARVEY'S MINE, NORTH BRANCH NYDECKER RUN, TWO AND ONE-HALF MILES NORTHWEST OF GORMAN.

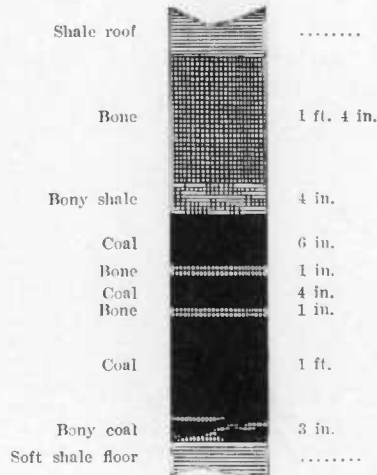

MINE ON WESTERN OUTSKIRTS OF GORMAN.

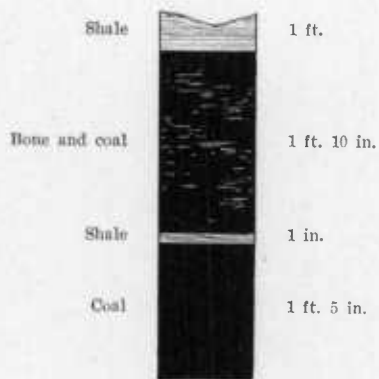

JAKE ANDERSON'S PROSPECT, MOON RIDGE, THREE MILES WEST OF WILSON.

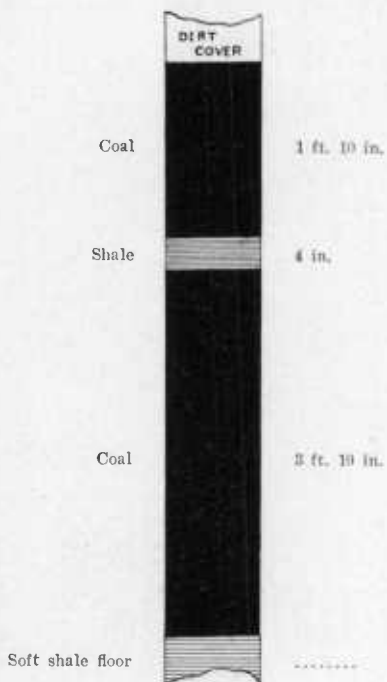

OPENING OPPOSITE GORMANIA.

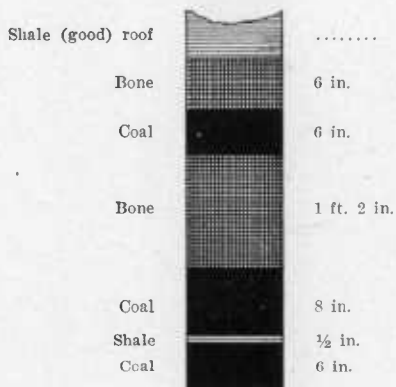

SECTION IN SHAFT ("THOMAS SEAM"), DAVIS COAL AND COKE COMPANY, HENRY.

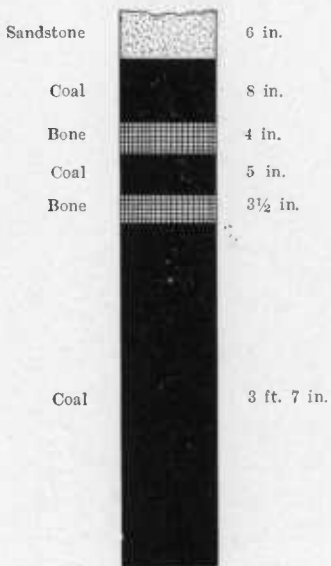

## DAVIS MINE ("THOMAS SEAM"), DAVIS COAL AND COKE COMPANY, THOMAS.

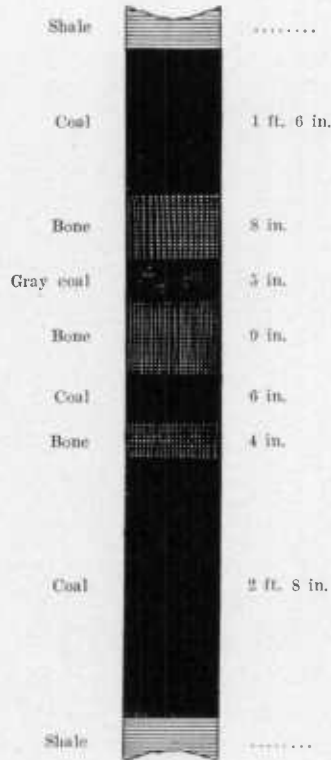

## THE CONEMAUGH COALS OF THE POTOMAC BASIN.

The Conemaugh coals are of very much less importance than the Allegheny coals and cover a much more restricted area. They consist of only a single seam that may be considered to have any considerable economic value, viz., the Bakerstown seam. On account of the small amount of coal developed in the formation it was named by the earlier geologists the Lower Barren Measures.

*Mahoning coal.*—This seam is very irregular and at no point in the Potomac basin attains to coal of economic value. At times it disappears altogether or is represented by a thin impure bed. It occurs between the Upper and Lower Mahoning sandstones at an interval of from 45 to 60 feet above the Upper Freeport coal.

*Section of Mahoning Coal.*

TASKER'S, ON RIVER FRONT, SEAM C, THREE-FOURTHS MILE NORTHWEST OF CHAFFEE.

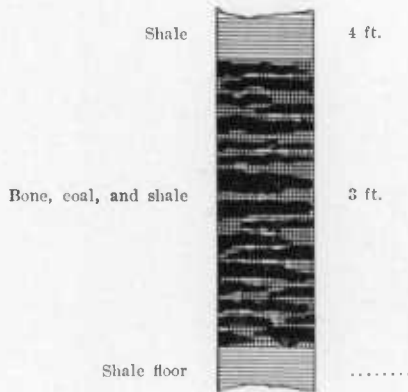

*Brush Creek (Masontown) coal.*—This seam is quite persistent and contains a bed of coal generally somewhat less than 2 feet in thickness. The coal where observed has been found to be of fair quality but the thickness of the seam does not indicate that it can be profitably developed in the Potomac basin. This bed occurs at an interval of about 95 feet above the Mahoning and from 75 to 100 feet above the Upper Freeport coal.

*Sections of Brush Creek Coal.*

TASKER'S, ON RIVER FRONT, SEAM B, THREE-FOURTHS MILE NORTHWEST OF CHAFFEE.

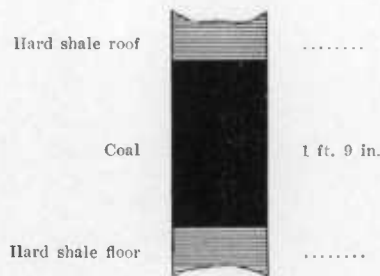



## HAMIL'S OPENING, ONE MILE NORTHWEST OF BLAINE.

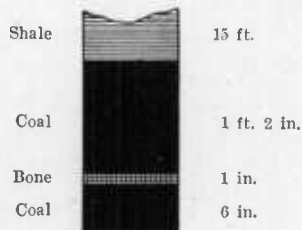

*Bakerstown* (*Barton* or "*Four-foot*") coal.—This seam is the most important of the Conemaugh coals. It is somewhat variable in thickness but very persistent although some of the layers are more or less bony. It has a thickness of from 2 to 4 feet, the thickest and best development of the coal being found in the northern part of the basin although it seldom attains that thickness. This seam occurs at an interval of from 90 to 135 feet above the Brush Creek coal.

*Sections of Bakerstown Coal.*

## PATTISON MINE, THREE-FOURTHS MILE NORTHWEST OF BLOOMINGTON.

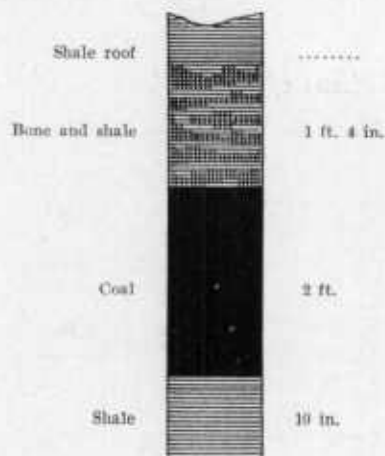

GEO. W. TICHINEL'S MINE, THREE-FORK RUN, ONE AND ONE-HALF MILES NORTH-  
WEST OF CHAFFEE.

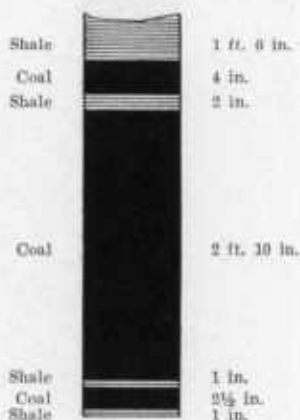

GEO. W. TICHINEL'S MINE, SAME LOCALITY AS PRECEDING.

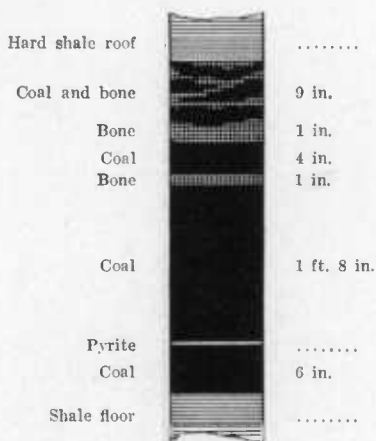

MONROE COAL MINING COMPANY, ONE MILE WEST OF BARNUM.

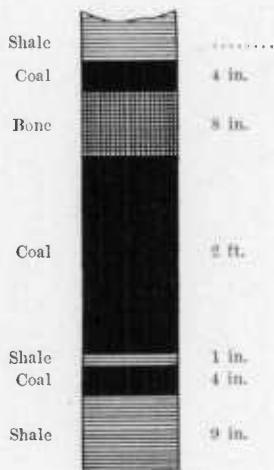

SHARPLESS MINE, TWO MILES SOUTHEAST OF SWANTON.

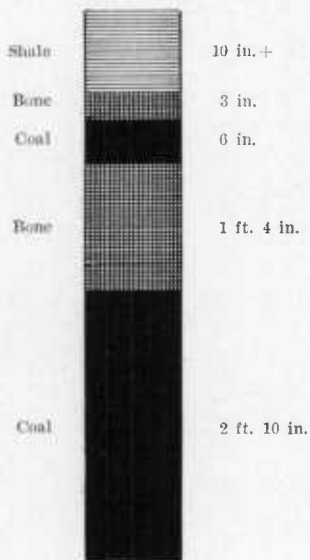

SECTION EAST OF SHAW (IN WEST VIRGINIA).

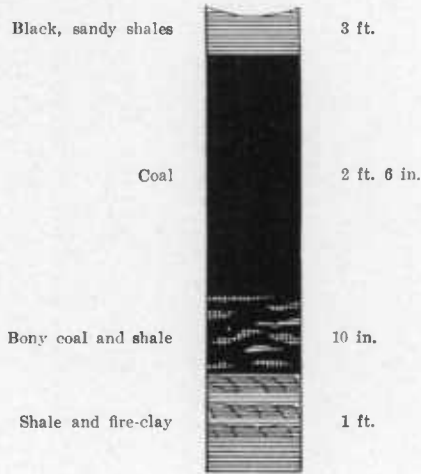

TASKER'S, ON RIVER FRONT, SEAM A, THREE-FOURTHS MILE NORTHWEST OF CHIAFFEE.

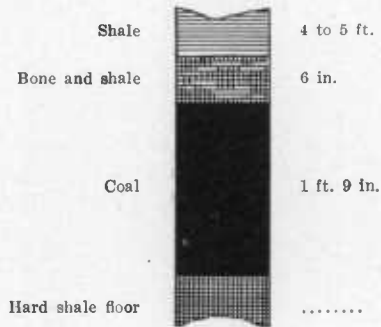

## RUDOLPH BECKMAN'S MINE, THREE MILES NORTHWEST OF BLAINE.

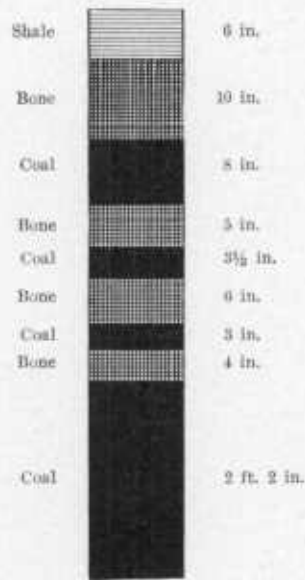

## HAMIL'S OPENING, ONE MILE NORTHWEST OF BLAINE.

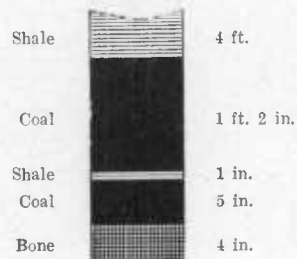

A. WILSON'S MINE, TWO AND ONE-HALF MILES NORTHEAST OF TASKER CORNERS.

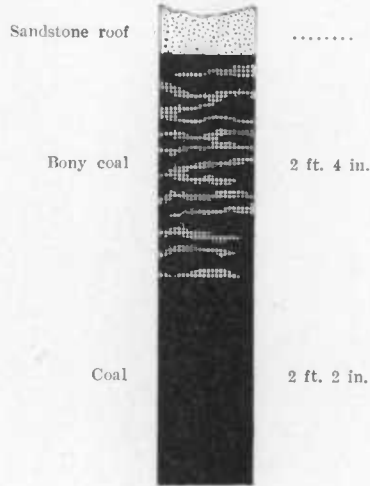

N. B. HARVEY'S MINE, ONE MILE NORTHWEST OF KEARNEY.

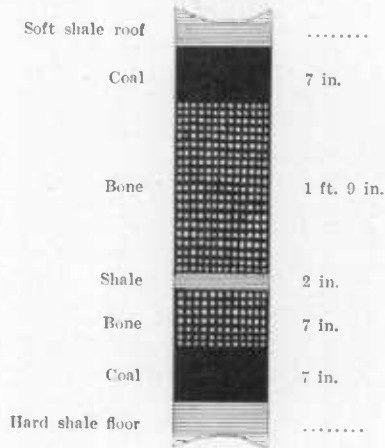

FIRE-COAL MINE ON STOYER PROPERTY, THREE-FOURTHS MILE NORTH OF STOYER.

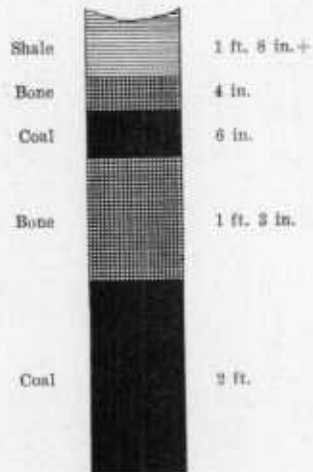

GEORGE STOYER'S MINE, ONE MILE NORTHEAST OF STOYER.

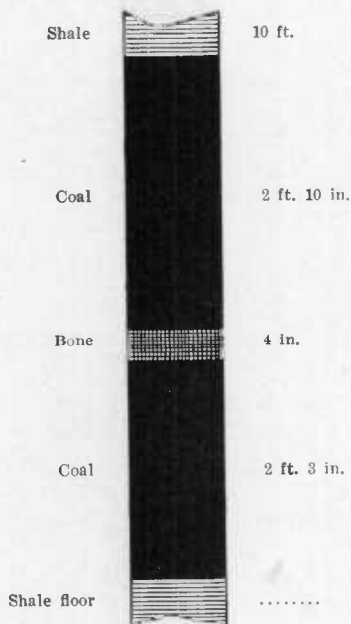

MINE THREE-EIGHTHS MILE NORTHWEST OF BAYARD.

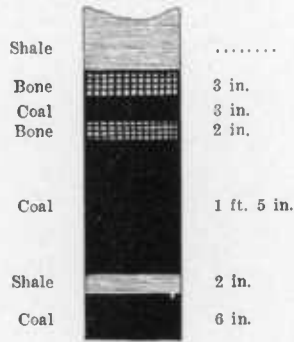

OPENING WEST OF SAWMILL AT BAYARD.

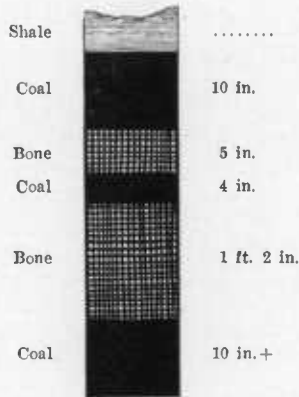



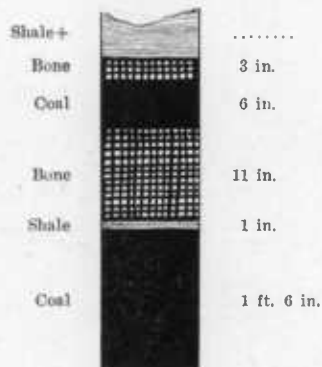

MINE ON HILL SOUTHEAST OF BAYARD.







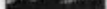

## SMALL OPENING TWENTY-NINE FEET ABOVE MOUTH OF SHAFT, HENRY.

Black shale		10 in.
Bony shale		6 in.
Bony coal		6½ in.
Shale		1 in.
Bony coal		5½ in.

*Friendsville (Crinoidal) coal.*—This seam is variable and at no point reaches a sufficient thickness to have more than local economic value. It is generally less than 2 feet in thickness although it slightly exceeds that amount at one point. Its quality is of good grade but its extent is not fully known. It has less areal extent than any other seams of the Potomac basin, being found well up in beds of Conemaugh formation. This seam occurs at an interval of about 100 feet above the Bakerstown coal and is apparently best developed in the southern or central portion of the Potomac basin.

*Sections of Friendsville Coal.*

## STOTTEMEYER'S MINE, ONE-HALF MILE EAST OF MT. ZION CHURCH.

Shale		7 in.
Bone		2 in.
Shale		2½ in.
Coal		1 ft. 11 in.
Shale		.....

JAMES HARVEY'S MINE, ONE AND ONE-FOURTH MILES SOUTH OF KELSO GAP.

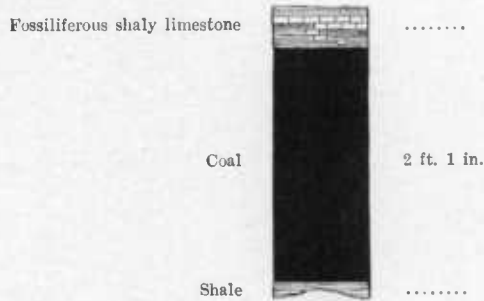

*Other coals.*—The higher seams of the Conemaugh formation are poorly developed in the Potomac basin. They all occur in limited areas, chiefly in the southern part of the basin where very few attempts have been made to examine them hitherto. It is doubtful whether any of them occur in sufficient thickness to possess an economic value.

THE MONONGAHELA COALS OF THE POTOMAC BASIN.

The Monongahela coals are practically absent from the Potomac basin, the beds of the Monongahela formation being found only in two very small isolated areas on the Maryland side of the North Branch of the Potomac river. The chief occurrence is on the hill to the northwest of Shaw where a thick but very small body of Pittsburg or "Big Vein" coal was found. This small tract was long since entirely worked out so that the coal there found has no economic significance at the present time. Another small area is found not far from the Fairfax Stone. A much larger tract of "Big Vein" coal occurs at Elkgarden on the West Virginia side of the river and has been extensively mined at that point for many years by the Davis Coal and Coke Company.

None of the Monongahela coals above the Pittsburg seam have been found in the Potomac basin as all of the strata above that horizon have been entirely removed by erosion.

*Sections of Pittsburg Coal.*

FIRE-COAL OPENING ONE AND THREE-FOURTHS MILES NORTHWEST OF SHAW.

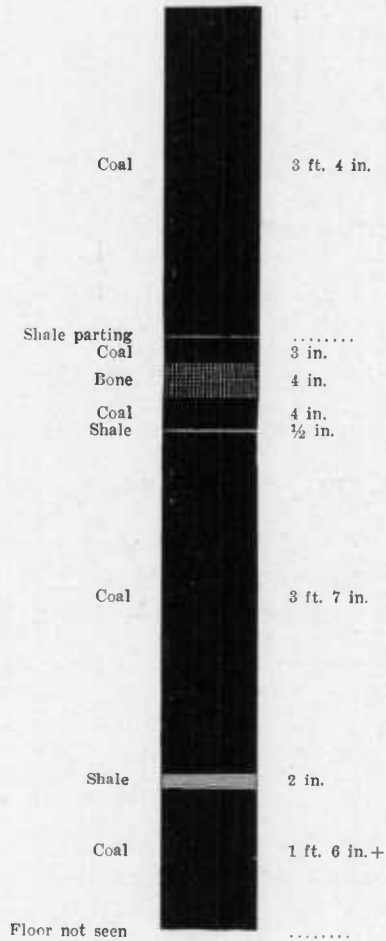

SECTION NO. 6 OPENING AT ELKGARDEN.

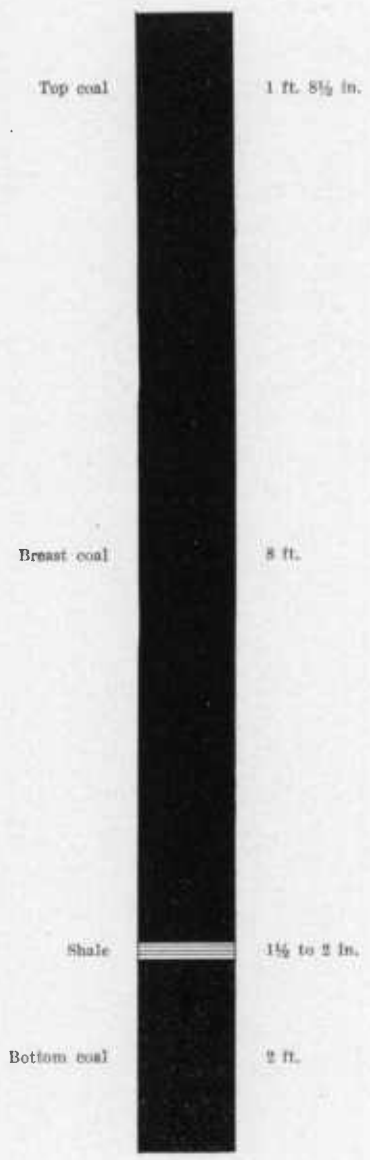

## THE CASTLEMAN BASIN.

The Castleman basin is a simple shallow syncline with gentle dips and a still gentler northeastward pitch of its axis. It does not contain any Pittsburg coal in its Maryland portion. The axis of the basin extends in an almost straight line through the eastern end of Grantsville, the forks of the Castleman river, and Bittering.

The Conemaugh seams can be almost entirely mined by drift from the Castleman valley. The only exception to this is that the Grantsville seam in the very center of the basin would have to be reached by slopes or shallow shafts.

The Allegheny seams are almost entirely shaft coal. They underlie a very large area but their thickness and quality are very imperfectly known. The bore-hole at Jennings Mill which gives our only section of them showed that they were not workable at this immediate point. They should be tested at other points, where they will probably be found to be workable under large portions of the valley. The bore-hole at Jennings Mill, which was located very slightly east of the axis of the basin, showed the Upper Freeport at a depth of 193 feet, and the Lower Kittanning at a depth of 341 feet. The detailed record of this boring is given on pages 250 and 253 of this report. These seams can be reached at approximately these depths anywhere along the line of Jennings Bros. R. R. The deepest part of the basin is somewhat west of the railroad.

## THE POTTSVILLE COALS OF THE CASTLEMAN BASIN.

The Pottsville coals have not been prospected to any extent in the Castleman basin. They are all thin, unimportant seams, as elsewhere in Maryland, and will probably never be found of sufficient thickness to have any economic value. The Pottsville formation outcrops around the margin of the basin but no coal seams of any significance have ever been observed at any point. The Mt. Savage coal has been found a short distance to the north of the Pennsylvania line but not of sufficient thickness to possess any value. There is

very little chance that any of the Pottsville seams will be found to have even local value and they are hardly worth the time and money that would be required to exploit and develop them.

*Mount Savage coal.*—The Mount Savage seam has little or no economic value in the Castleman basin. Traces of its presence may be found here and there below the Homewood sandstone and an opening has been made on Piney Run a short distance north of the Mason and Dixon Line. At this point it is very impure and bony and offers little inducement for further prospecting for this seam in the Maryland portion of the basin.

*Section of Mount Savage Coal.*

OPENING ON PINEY RUN, A SHORT DISTANCE NORTH OF THE MARYLAND-PENNSYLVANIA LINE.

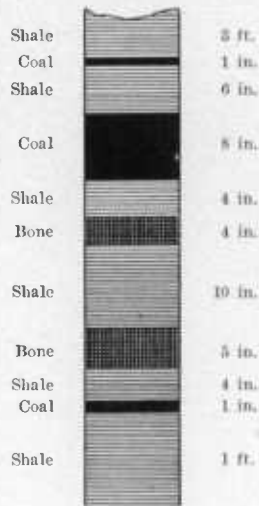

THE ALLEGHENY COALS OF THE CASTLEMAN BASIN.

The Allegheny coals lie at considerable depth beneath the Castleman basin except around the margins of the syncline. They have been very little prospected hitherto and the thickness and extent of these coals are less fully known in this basin than elsewhere in the State.

More extensive drilling will be required to determine the value and extent of the Allegheny coals than has been hitherto undertaken. The single bore-hole at Jennings Mill does not show that the Allegheny coals at that point have any great thickness but as all of the seams vary more or less from point to point the extent and character of the Allegheny coals cannot be considered as proven by a single drilling. It is quite possible that none of the seams will be found to have the same thickness in this region as in the other basins but there is hardly sufficient information at the present time to determine definitely this point. The Allegheny coals present in workable seams will be found to cover a much larger area than the higher coals but will have to be reached over the greater part of the basin by comparatively deep shafts.

*Section of Brookville Coal.*

OPENING ON PINEY RUN NORTH OF MARYLAND-PENNSYLVANIA LINE.

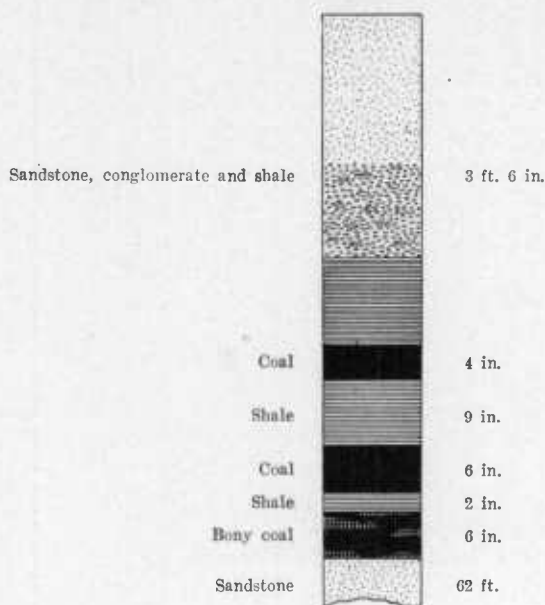

*Brookville (Bluebaugh) coal.*—The Brookville seam has probably very little economic value in the Castleman basin. It has been found a short distance to the north of the Pennsylvania line where the coal shows a thickness of less than 1 foot. It has not been opened at any point within the Maryland portion of the basin and there are no indications that the coal will be found in sufficient quantity to be of any value.

*Clarion (Parker) coal.*—The Clarion seam is much better developed than the Brookville in the Castleman basin, having been found at a number of points of sufficient thickness to show its probable commercial value. It has not been seen over any large portion of the basin since it is deeply buried except around the margins and more prospecting work will be required before the extent and character of the coal can be fully determined. The Clarion seam is found from 15 to 30 feet above the base of the Allegheny formation. It shows a thickness of over 3 feet of good coal.

*Sections of Clarion Coal.*

OPENING ON PINEY RUN NORTH OF THE MARYLAND-PENNSYLVANIA LINE.

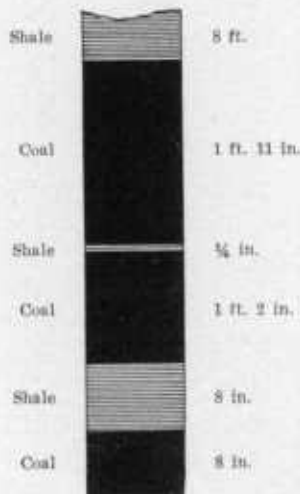



## OPENING OF M. LEGER, THREE MILES NORTHWEST OF BITTINGER.

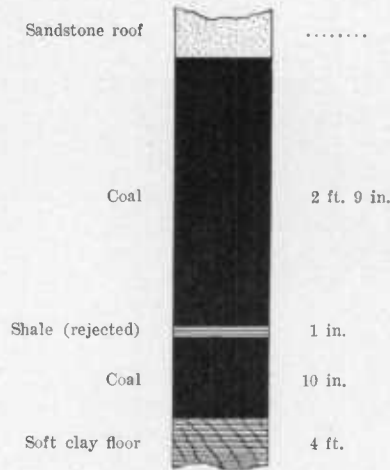

*Lower (and Middle) Kittanning (Bender) coal.*—This seam, so important in the Georges Creek and Potomac basins, has much less thickness in the Castleman basin, although the extent and character of the coal are not as fully worked out in the latter area as in the former. This seam is deeply buried over most of the basin while comparatively few openings have been made around the margin of the region. The single bore-hole at Jennings Mill shows that the seam is not very thick at that point but as this coal is more or less variable in the other basins this single bore-hole does not finally determine the character of this seam. To the north of the Pennsylvania line this coal is found of workable thickness and it is probable that it will upon further investigation be found to be important from a commercial standpoint over portions at least of the Castleman basin. This coal occurs from 90 to 150 feet above the base of the Allegheny formation and from 170 to 210 feet below the top. It has been locally known in the Castleman basin under the name of the Bender seam.

*Sections of Lower Kittanning Coal.*

OPENING ON PINEY RUN, NORTH OF THE MARYLAND-PENNSYLVANIA LINE.

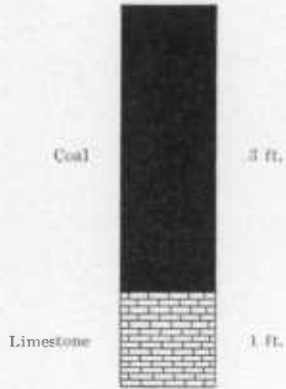

OPENING ON PINEY RUN, NORTH OF THE MARYLAND-PENNSYLVANIA LINE.

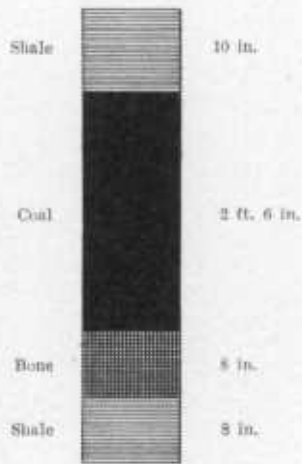

JOEL BENDER'S OPENING, THREE AND ONE-HALF MILES EAST OF MCHENRY.

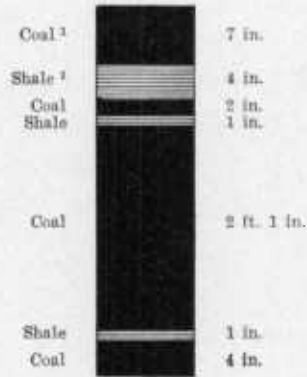

ANOTHER MEASUREMENT FURTHER IN, AT SAME LOCALITY.

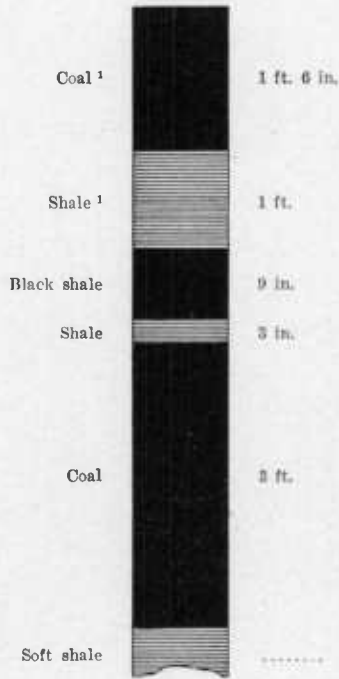

<sup>1</sup> As reported by Mr. Bender.

*Lower Freeport coal.*—A coal seam supposed to represent the Lower Freeport is found at several points in the Castleman basin although its exact equivalent elsewhere cannot be determined with absolute certainty. This seam appears at a distance of 35 to 60 feet below the top of the Allegheny formation and contains 1 foot 6 inches to 2 feet of coal although the latter is badly broken up by shale and bone coal. The seam where observed is hardly of sufficient thickness to have more than very local value.

*Sections of Lower Freeport Coal.*

HENRY YOMMER'S OPENING, LITTLE LAUREL RUN, ONE MILE EAST OF JENNINGS MILLS.

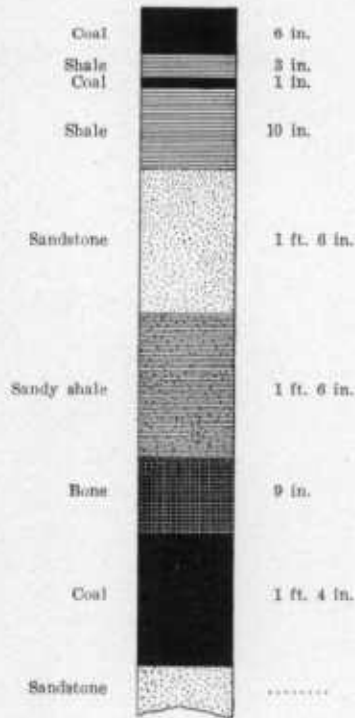

OPENING OF WILLARD FRICKEY, TWO AND ONE-HALF MILES NORTHWEST OF BITTINGER.

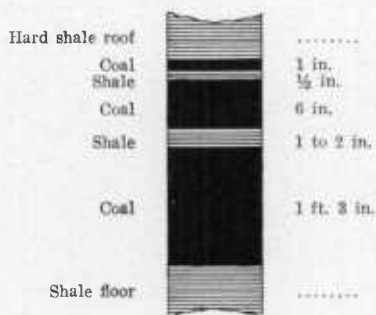

OPENING OF JOHN BRENEMAN, THREE MILES WEST-SOUTHWEST OF BITTINGER.

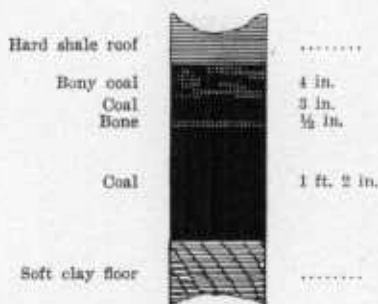

*Upper Freeport coal.*—The Upper Freeport coal is apparently very poorly developed in the Castleman basin as no prospect openings have been made in it. This seam is penetrated, however, in the bore-hole at Jennings Mills where it shows a thickness of somewhat under 3 feet separated into two bunches by bone and shale. This seam is so persistent and important in the other basins that it is possible that further exploration will result in locating this coal in workable quantities throughout portions of the basin and the drilling of the region for this coal would be fully warranted as it lies at a much higher level than the Lower Kittanning coal and could therefore be reached in much shallower shafts or around the margin by slopes.

*Section of Upper Freeport Coal.*

## BORE-HOLE AT JENNINGS MILLS.

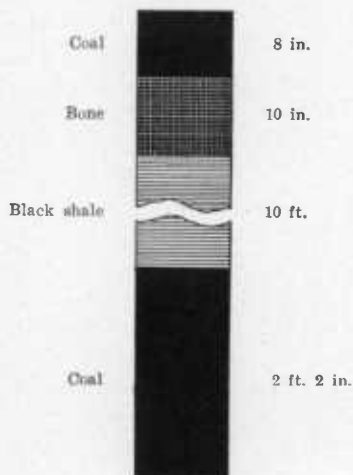

## THE CONEMAUGH COALS OF THE CASTLEMAN BASIN.

The Conemaugh coals are much better known in the Castleman basin than the Allegheny coals as they occur nearer the surface and have been frequently dissected by the main drainage lines of the valley so that the coal appears in outcrop at many points. The coal seams of the Conemaugh formation have been the chief source of local consumption in the past and will probably be the most important sources of coal in the valley unless further drilling of the district should show the presence of thicker seams in the Allegheny formation than have been thus far encountered. The Conemaugh formation shows some variations in the Castleman basin from its typical development in the Georges Creek and Potomac basins, two seams of coal appearing in the Castleman basin that have not been recognized elsewhere. One of these, which has been called the Grantsville seam, contains the most important bed of coal hitherto discovered in the area and has already been worked at a number of points.

*Mahoning coal.*—The presence of this seam is indicated along the North Branch of the Castleman river although there is some doubt as to the equivalency of the seam observed. This coal occurs at an interval of 45 to 60 feet above the Upper Freeport coal but on account of the large amount of shale and bone is probably unworkable except for purely local uses.

*Section of Mahoning Coal.*

PROSPECT ON NORTH FORK OF CASTLEMAN RIVER, ONE AND ONE-HALF MILES  
NORTHWEST OF BITTINGER.

Shale		4 ft.
Coal		1 in.
Shale		4 in.
Bone		4 in.
Coal		4 in.
Shale		8 in.
Coal		9 in.
Shale		4 in.
Coal		6 in.
Shale		8 in.
Coal		1 ft. 2 in.
Shale		1 in.
Coal		7 in.
Shale		3 in.
Coal		3 in.
Shale		7 in.
Coal		2 in.
Shale		8 in.

*Brush Creek (Masontown) coal.*—This seam occurs at an interval of from 85 to 125 feet above the Upper Freeport coal. It is very persistent in the Georges Creek basin but has not been exposed to any extent within the Castleman basin and is possibly absent at some points. This seam shows a thickness of somewhat over a foot in the bore-hole at Jennings Mills. It is not probable that it will be found at any point of sufficient thickness to be of commercial value.

*Section of Brush Creek Coal.*

BORE-HOLE AT JENNINGS MILLS.

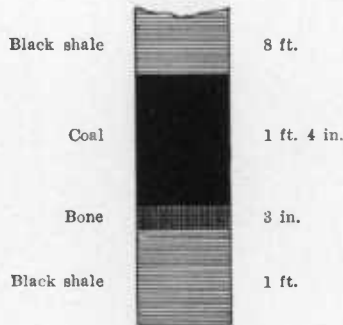

*Grantsville (Beachey) coal.*—This seam has not been observed in any of the other basins and apparently has no named equivalent in adjacent regions in Pennsylvania. It occurs at an interval of about 150 feet above the base of the formation and at an interval of 50 to 75 feet below the Bakerstown coal. It generally contains between 2 and 3 feet of coal although it has been found at one point on the North Branch of the Castleman river to exceed 5 feet in thickness. Further exploitation of this coal will probably reveal considerable areas of commercial value. It lies for the most part above water and can be obtained by drift mining.



*Sections of Grantsville Coal.*

BIG SHADE RUN, JUST NORTH OF MARYLAND-PENNSYLVANIA LINE.

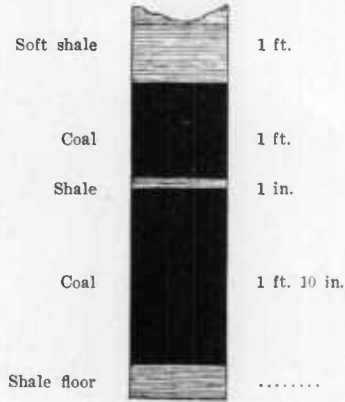

HENRY BONIC'S MINE, NEAR CROSS-ROADS, TWO MILES WEST OF GRANTSVILLE.

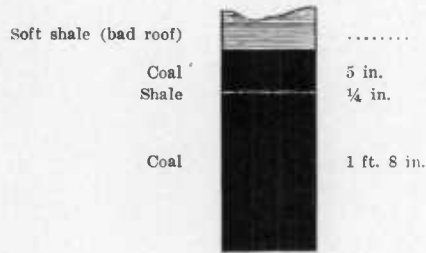

MINE NEAR NATIONAL ROAD, ONE AND ONE-HALF MILES WEST OF GRANTSVILLE.

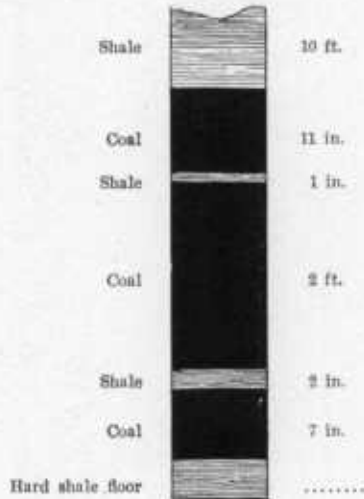

SECTION OF LOWER VEIN, AARON BEACHEY'S MINE, ABOUT ONE MILE WEST OF GRANTSVILLE.

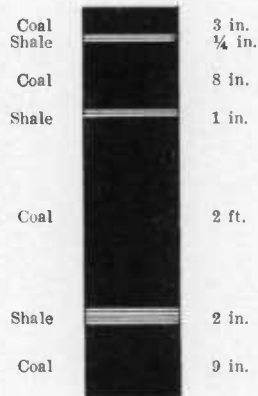

STANTON MINE, NORTH END OF RIDGLEY HILL, SOUTH OF JENNINGS MILLS.

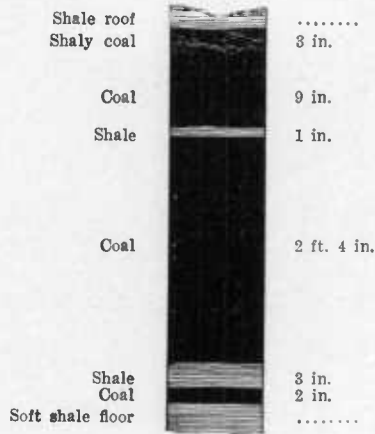

RIDGLEY'S MINE, INSIDE SECTION, RIDGLEY HILL, NORTHWEST OF BEVANVILLE.

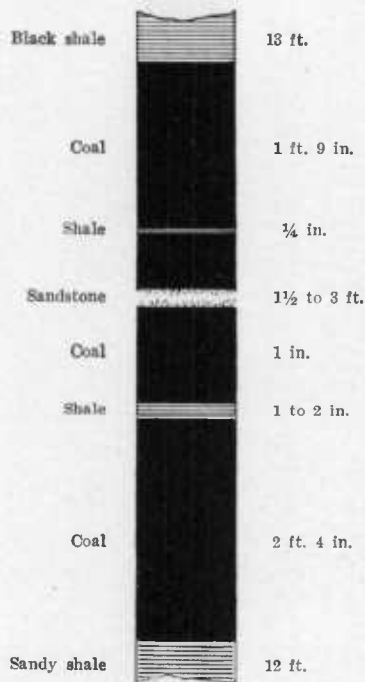

RIDGLEY'S MINE, SECTION AT OUTCROP, RIDGLEY HILL, NORTHWEST OF BEVANSVILLE.

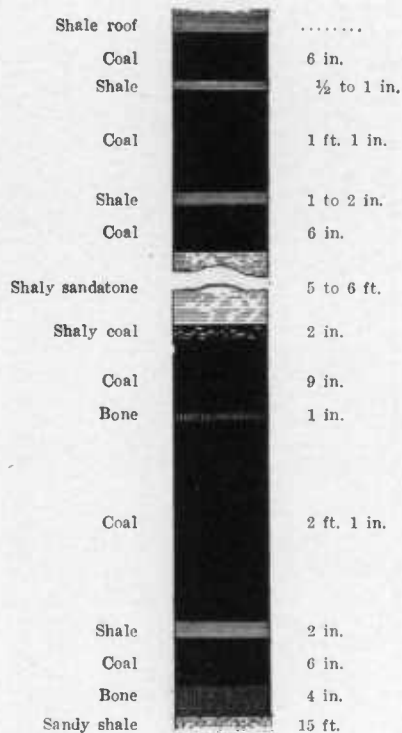

PROSPECT ONE MILE EAST OF JENNINGS MILLS.

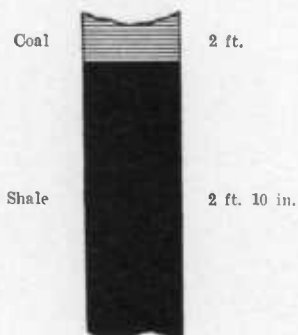

## MINE ON HILL ONE MILE EAST OF JENNINGS MILLS.

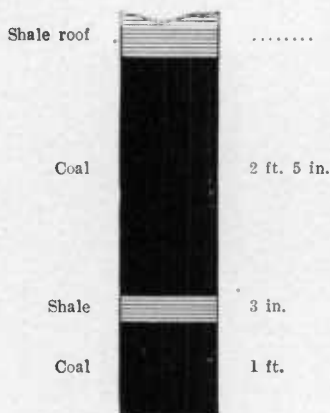

## JAKE BITTINGER MINE, ONE AND THREE-FOURTHS MILES EAST OF BITTINGER.



*Bakerstown (Honeycomb) coal.*—The Bakerstown seam occurs at from 175 to 200 feet above the base of the Conemaugh formation. It has been locally called the Honeycomb seam in the Castleman basin and has been locally mined at many points in the past. It is generally something over 2 feet in thickness. The seam is variable, however, and may some times almost disappear while at other times it may reach nearly if not quite 3 feet in thickness. It has been reached over considerable areas by drift and is one of the important and persistent seams of the basin.

*Sections of Bakerstown Coal.*

RAILROAD CUT ALONG CASTLEMAN RIVER, ONE MILE SOUTH OF NATIONAL ROAD.

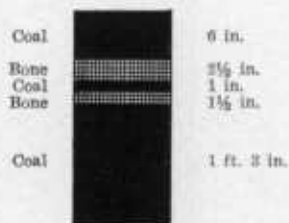

W. STANTON'S MINE ON SPIKER RUN, ONE AND ONE-HALF MILES SOUTHWEST OF GRANTSVILLE.

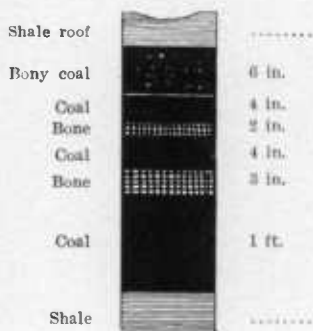

KINSINGER'S MINE, NEAR FORKS OF CASTLEMAN RIVER.

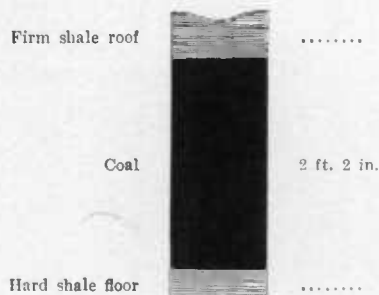

MINE AT RAILROAD BRIDGE NEAR FORKS OF CASTLEMAN RIVER.

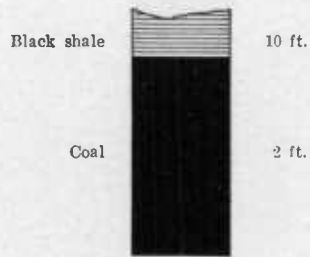

ROSS COMPTON'S MINE, SALT BLOCK MOUNTAIN.

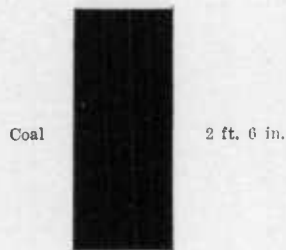

CREG BEVAN'S MINE, NORTH OF JENNINGS MILLS.

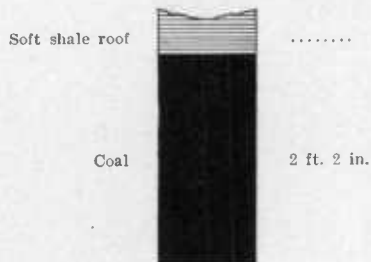

J. L. DURST MINE, NEAR JENNINGS MILLS.

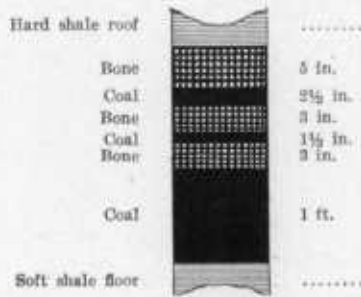

J. HANDWERK'S MINE, NEAR JENNINGS MILLS.

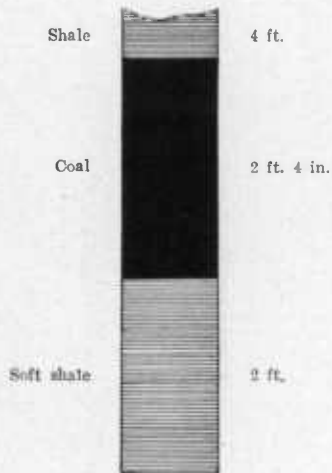

JOHN MILLER'S MINE, NEAR JENNINGS MILLS.

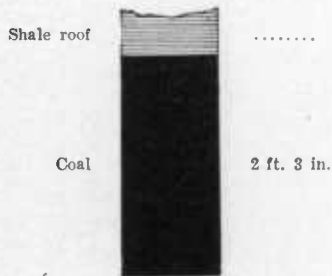



HAMPTON BUTLER'S MINE, ONE AND ONE-HALF MILES SOUTHEAST OF JENNINGS MILLS.

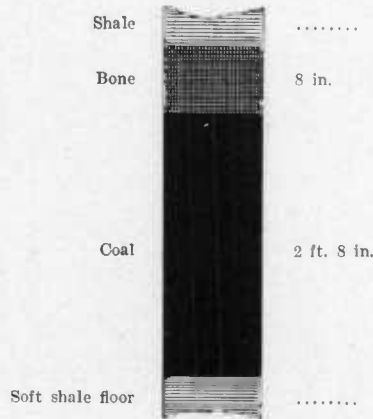

PROSPECT ON MAYNADIER TRACT (MORGART'S), TWO MILES SOUTH OF JENNINGS MILLS.

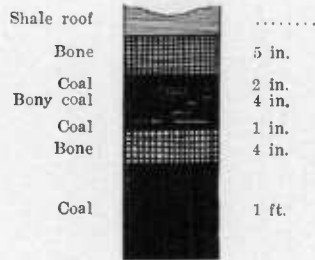

GEORGE BREW'S MINE, ONE AND ONE-FOURTH MILES EAST OF BITTINGER.

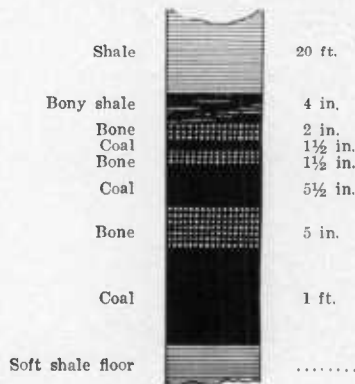

BRENEMAN AND STARK'S MINE, NORTHEAST OF BITTINGER.

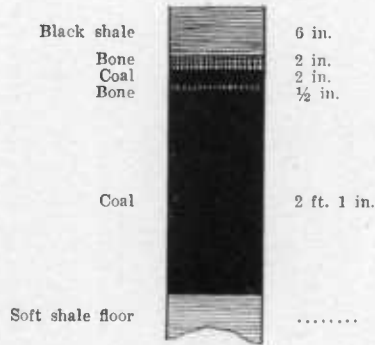

PETER LOHR'S MINE, ONE MILE SOUTHEAST OF BITTINGER.

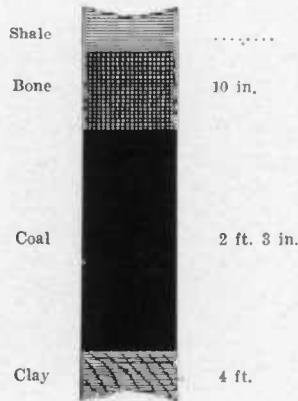

JOEL BRENEMAN'S MINE, ONE AND ONE-HALF MILES SOUTH OF BITTINGER.

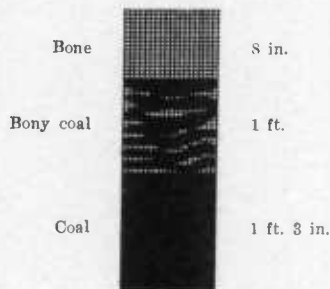

## F. N. BITTINGER'S MINE, TWO AND ONE-HALF MILES SOUTHWEST OF BITTINGER.

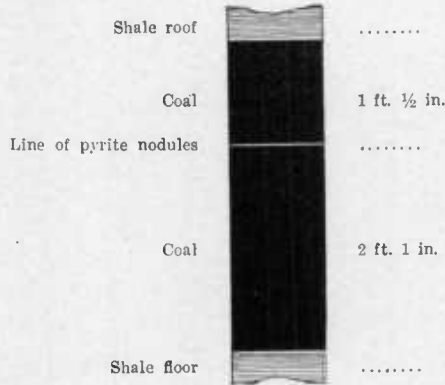

*Maynadier coal.*—This seam is also confined to the Castleman basin and is found at an interval of about 25 feet above the Bakers-town coal. It has no known equivalent in the other basins. The coal has a thickness of between 2 and 3 feet although it is frequently bony and is also divided by shale partings into two or more benches. It probably has no commercial value on account of its thinness and poor quality.

*Sections of Maynadier Coal.*

## RAILROAD CUT ALONG CASTLEMAN RIVER, ONE MILE SOUTH OF NATIONAL ROAD.

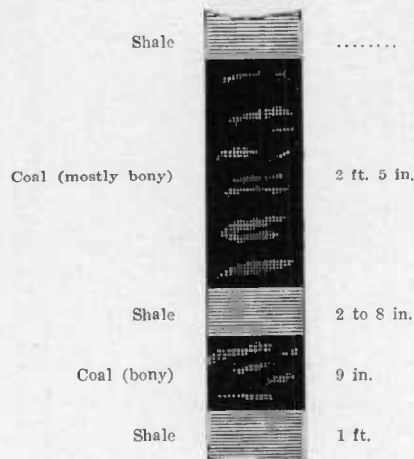

L. YOMMER'S OPENING, NORTHEAST OF JENNINGS MILLS.

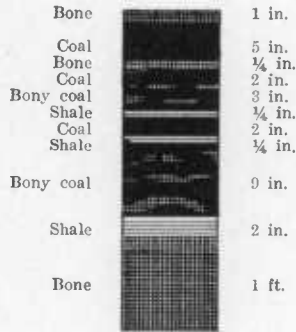

PROSPECT ON MAYNADIER TRACT (MORGART'S), TWO MILES SOUTH OF JENNINGS MILLS.

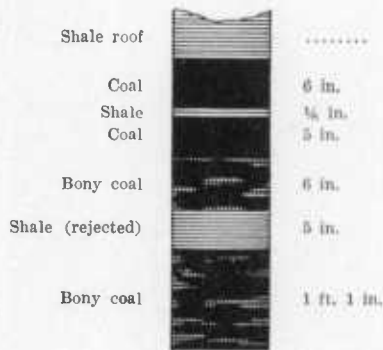

*Friendsville (Crinoidal) coal.*—The Friendsville seam is found at an interval of about 100 feet above the Bakerstown coal and contains from 1 foot 6 inches to 2 feet of coal with one or more thin shale partings. This coal has been called the Crinoidal coal in Pennsylvania but the name Friendsville has been applied to it because it is well developed near that place in the Lower Youghiogeny basin. It is not an important seam and probably will not be found of sufficient thickness to have more than local commercial value.

*Sections of Friendsville Coal.*

OPENING ON BIG SHADE RUN, ONE MILE WEST OF GRANTSVILLE.

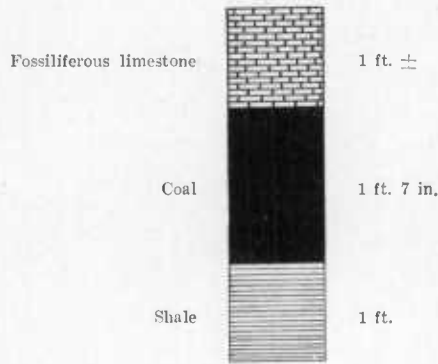

JOHN WILEY'S MINE, ONE MILE EAST OF BEVANVILLE.

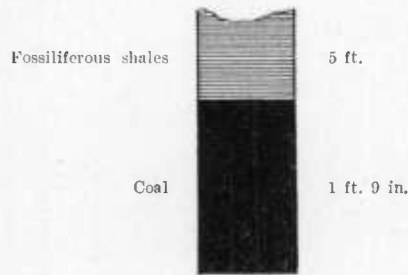

HENRY BEIZEL, PLEASANT VALLEY RUN, TWO MILES SOUTHEAST OF BITTINGER.

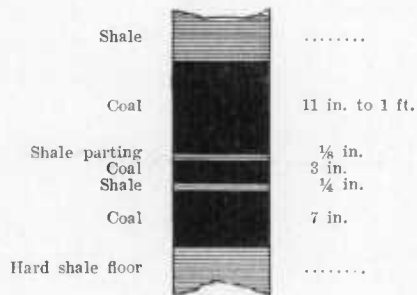

*Other coals.*—The higher Conemaugh seams are poorly developed in the Castleman basin although the Franklin coal has been observed to the north of the Pennsylvania line. The Conemaugh formation has been extensively eroded over much of the Castleman basin so that these upper seams even if present in workable thickness would have little extent and little economic value.

#### THE UPPER YOUGHIOGHENY BASIN.

The Upper Youghiogheny basin is a broad shallow syncline, which undulates somewhat in its central part. The Monongahela coals, and the workable Conemaugh coals (excepting one area of the Bakerstown coal) are entirely absent from it. The Upper Freeport coal is workable in a few areas, especially along the Youghiogheny river below the mouth of Miller Run. It is largely drift coal. The Lower Kittanning coal underlies the larger part of the basin and has been mined to a small extent along the outcrop. It is almost all slope and shaft coal.

#### THE POTTSVILLE COALS OF THE UPPER YOUGHIOGHENY BASIN.

Very little is known regarding the thin coal seams of the Pottsville formation in the Upper Youghiogheny basin except that they are known to be thin and of practically no economic value, as very little prospect work has been done on them. The beds of the Pottsville formation outcrop around the margin of the synclinal basin but at no point have coals of any significance been observed. It is, moreover, probable that no coals even of local value will be discovered in this area and prospect work at this horizon cannot be expected to yield returns commensurate with the outlay of time and money involved.

The Sharon coal has been recognized in an abandoned drift about two and a half miles north of Oakland on the road to Swallow Falls where this seam was once worked for local use. The working is not now exposed but is locally reported to have a thickness of between 3 and 4 feet and to be of satisfactory quality. There is a consider-

able area in the vicinity which could be worked by drift and a larger area which could be worked by slope or shaft should further investigations show that the seam has a sufficient thickness and quality over a large enough territory. A few miles to the northwest near the West Virginia line and on the opposite flank of this basin the seam has been reported by Dr. I. C. White<sup>1</sup> as having a thickness of about 3 feet and as being quite soft and pure and like the coking type of the New River coals.

The Quakertown coal has also been observed in the gorge below Swallow Falls where it has a thickness of about eighteen inches but there is little indication that this seam possesses any commercial value.

*Section of Mt. Savage Coal.*

RAILROAD CUT NEAR SWALLOW FALLS, GARRETT COUNTY.

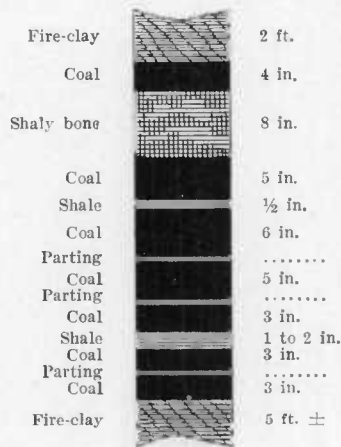

*Mt. Savage (Upper Mercer) coal.*—This seam occurs from 25 to 75 feet below the top of the Pottsville formation. It varies largely in thickness and quality and has been found to be of little value anywhere in the State except for local purposes. No outcrops of this coal have been observed in the Upper Youghiogheny basin except in

<sup>1</sup> Bull. U. S. Geol. Survey, No. 65, p. 202.

the vicinity of Swallow Falls where an excellent section is exposed in the railroad cutting on the side of the valley. The coal is a good deal broken by shale partings and it is not probable that it will be found to have any commercial value.

THE ALLEGHENY COALS OF THE UPPER YOUGHIOGHENY BASIN.

The Allegheny coals underlie the greater part of the basin although the upper beds of the formation have been more or less dissected by streams while the cover of later formations is less extensive than in the Castleman basin so that the Allegheny coals, where present, may be in part reached even in the center of the basin by drifts although the lower coals must mainly be mined by slopes and shafts. These beds also outcrop around the margins of the syncline where they have been opened to some extent. The Allegheny coals are the most important coals of this basin and along its western margin have already been mined to some extent. Further development work will be necessary before the full extent of the coals can be finally determined. The lowest coals are poorly developed although the Clarion seam has been recognized in the southwestern part of the basin.

*Section of Clarion Coal.*

PROSPECT NEAR PRESTON COAL AND LUMBER COMPANY'S NEW TIPPLE, TWO MILES SOUTHWEST OF CRELLIN.

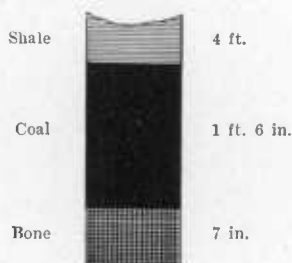

*Clarion coal.*—The Clarion coal occurs at an interval of from 12 to 30 feet above the bottom of the Allegheny formation. It has only been observed at one point in the southwestern part of the area near



the West Virginia line where it does not occur in sufficient thickness to have any commercial value.

*Lower (and Middle) Kittanning coal.*—This seam is the most persistent and most extensively developed of any of the Upper Yougheny basin and has been mined at various points within the dis-

*Sections of Lower Kittanning Coal.*

THOMAS SKIPPER'S MINE, TWO MILES ABOVE MOUTH OF DEEP CREEK, TWO MILES EAST OF SWALLOW FALLS.

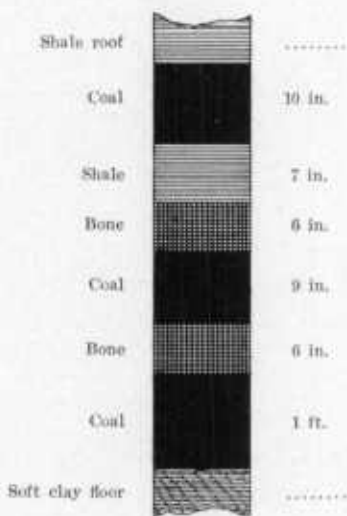

trict, especially in the southwestern part of the region. This seam has a thickness of from 4 to 6 feet, although it is a good deal broken by partings of shale. Bone coal is also more or less prevalent. It is probable, however, that at some points this seam will be found to have considerable economic value. It has been called locally the Corinth or "Four-foot" vein. It is probable, as in more eastern basins, that this seam represents both the Lower and Middle Kittanning coals of Pennsylvania. At some points the coal has a thick parting of shale near the middle of the seam. This seam occurs at an interval of between 90 and 150 feet above the base of the formation

and from 170 to 210 feet below the top. It covers a far greater area than any of the later coals and, although cut by the Youghio-gheny river throughout the lower portion of the district, will probably have to be mined mainly by slope or shaft.

JOHNNY BOLE MINE (NETHKEN'S), WEST SIDE ROMAN NOSE MOUNTAIN, FOUR AND ONE-HALF MILES NORTHEAST OF OAKLAND.

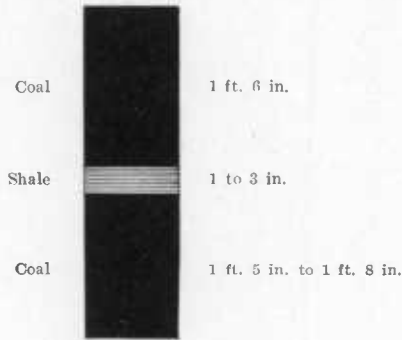

JAMES W. FODGE OPENING, EAST SIDE SNAGGY MOUNTAIN, FIVE AND ONE-HALF MILES NORTHWEST OF OAKLAND.

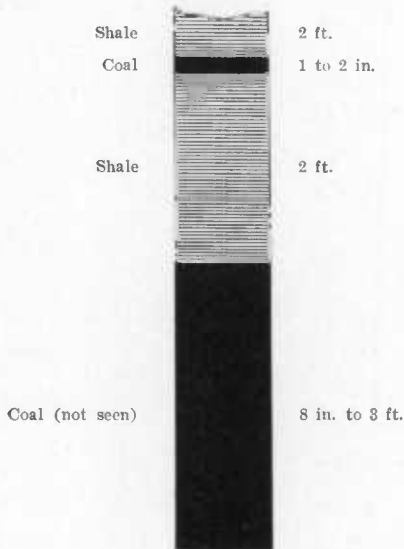

## MINE SOUTH OF OAK SHOALS, THREE MILES NORTH-NORTHWEST OF OAKLAND.

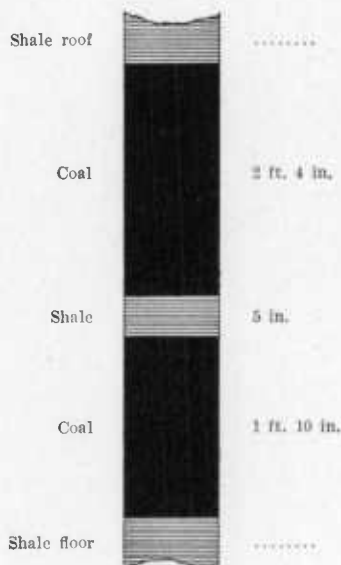

## TEST HOLE ON BRANCH OF HERRINGTON CREEK, THREE AND ONE-HALF MILES NORTHWEST OF OAKLAND.

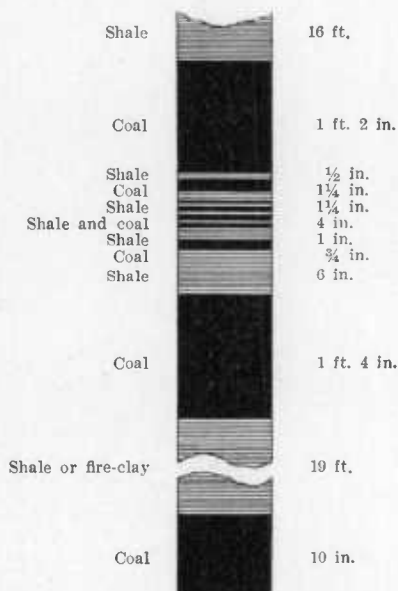

WORKING MINE OF OAKLAND COAL AND COKE COMPANY, ONE-HALF MILE SOUTH-  
WEST OF CORINTH.

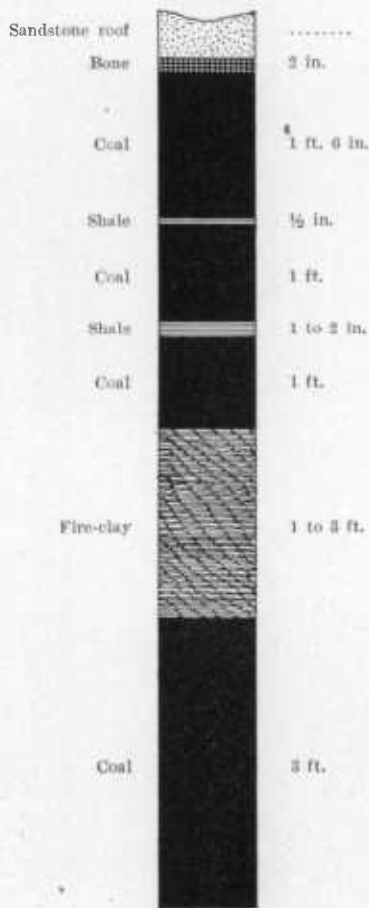

OFFUT'S MINE, EAST SIDE YOUGHIOGHENY RIVER, ONE AND ONE-HALF MILES  
NORTHEAST OF CRELLIN.

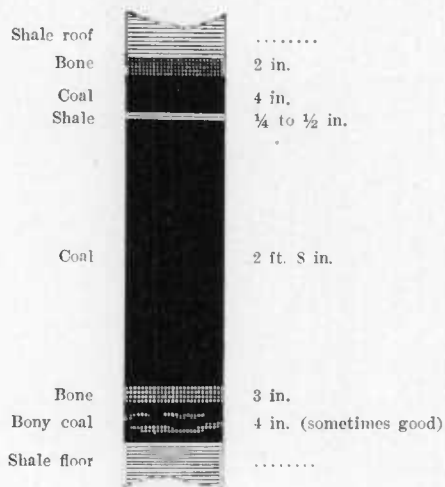

CRANE'S MINE (PRESTON COUNTY, W. VA.), ON LAUREL RUN, WEST OF BROWN-  
BAUER LINE, TWO AND ONE-HALF MILES WEST OF CRELLIN.

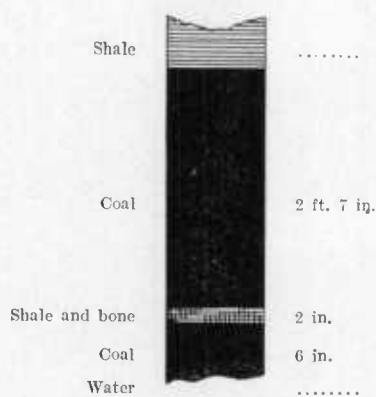



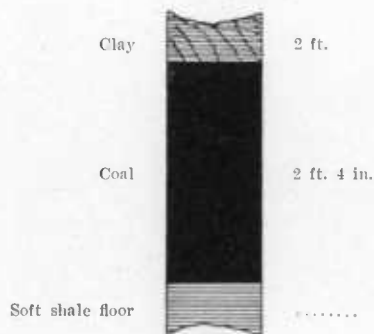



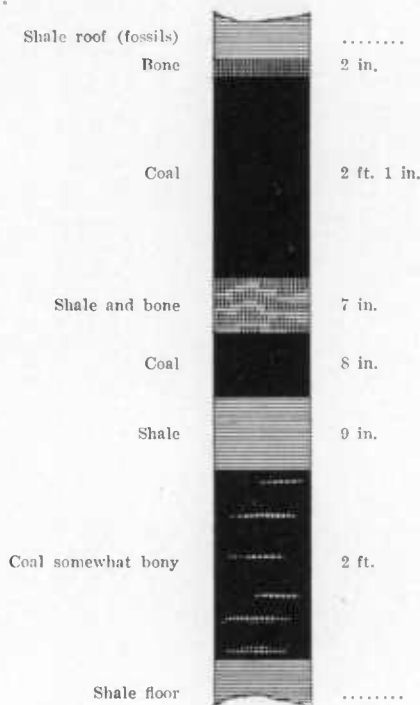

OLD OPENING, TWO HUNDRED FEET WEST, SOUTH SIDE OF ROAD, ONE-HALF MILE  
SOUTHEAST OF CRELLIN.













VAN WERTH'S MINE (PRESTON COUNTY, W. VA.), THREE MILES WEST OF CRELLIN.

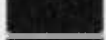

OLD OPENING ON ARNOLD'S RUN, TWO AND ONE-HALF MILES SOUTHWEST OF  
CRELLIN.

Shale		1 ft.
Coal		2 ft. 4 in.
Bone Shale		1½ in. 1½ in.
Coal		8 in.
Shale		¼ in.
Coal		4 in.
Shale		1 ft.
Coal		1 ft.

GUTHRIE'S MINE, ON PRESTON R. R., THREE MILES SOUTHWEST OF CRELLIN.

Shale roof		.....
Coal and bone		3 in.
Shale		3 in.
Coal		6 in.
Shale		0 to ½ in.
Coal		1 ft. 8 in.
Shale		¾ to 1 in.
Coal		2 in.
Shale		1 to 3 in.
Coal		9 in.
Shale		10 in. to 1 ft.
Coal		1 ft.

ASHBY'S MINE, ONE MILE SOUTH-SOUTHWEST OF CREILIN.

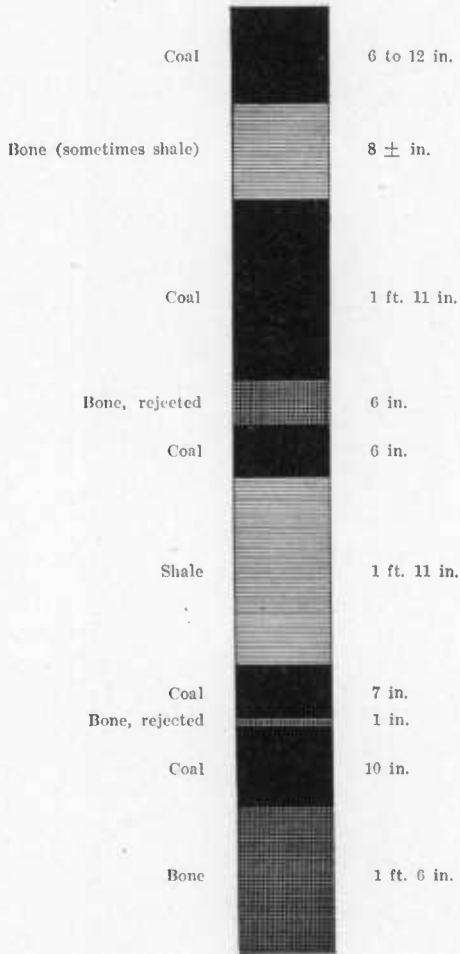



## CROP OPENING, ARNOLD'S RUN, THREE MILES SOUTHWEST OF CRELLIN.

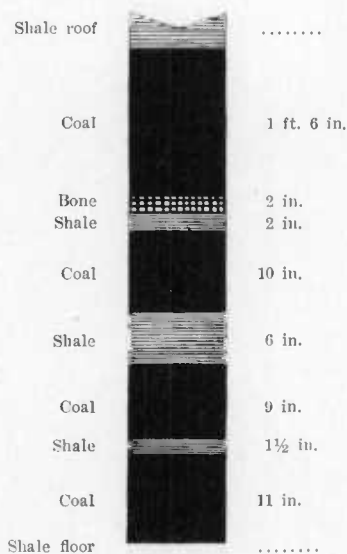

## PRESTON COAL AND LUMBER COMPANY, ON PRESTON R. R., THREE AND ONE-HALF MILES SOUTHWEST OF CRELLIN.

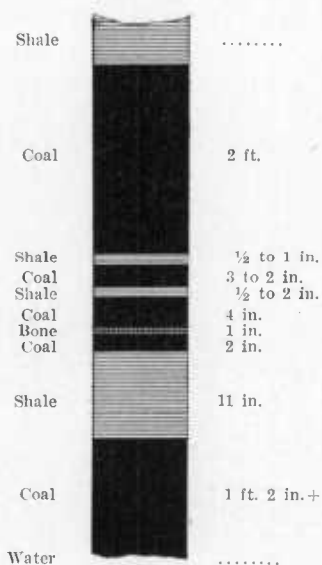

PRESTON COAL AND LUMBER COMPANY'S NEW TIPPLE, FOUR MILES SOUTHWEST OF CRELLIN.

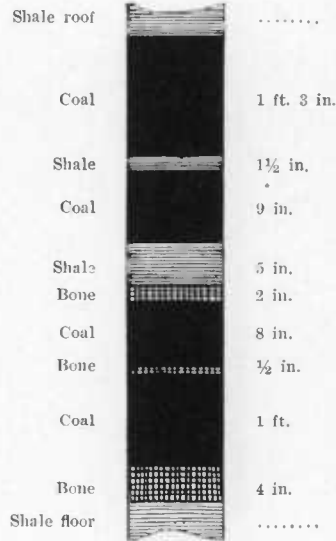

*Lower Freeport coal.*—This seam has been observed at a number of points in the upper part of the basin. It has a thickness of fully two feet, although the bed is somewhat broken by shale and bony

*Sections of Lower Freeport Coal.*

OPENING ON CREST OF RIDGE, TWO MILES NORTHWEST OF OAKLAND.

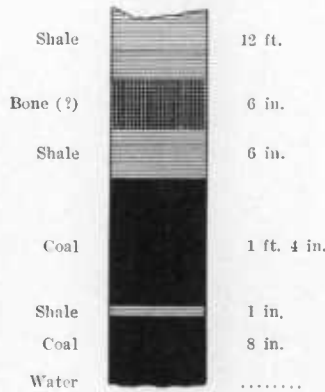

layers. This seam occurs at an interval of from 100 to 145 feet above the Lower Kittanning coal and is commonly found from 35 to 60 feet below the top of the Allegheny formation. It is not probable that this coal will be found to possess more than local value.

T. A. CONNELL'S MINE, NORTH OF RAILROAD AND THREE-FOURTHS MILE WEST OF CRELLIN.

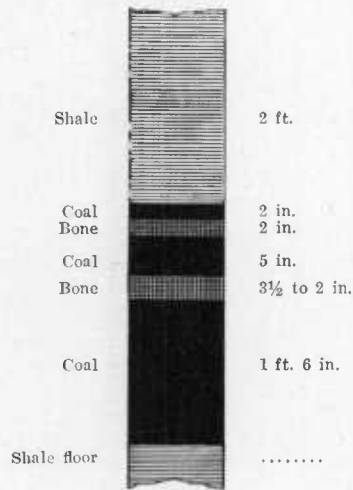

MINE ONE MILE WEST OF CRELLIN ON OLD MARYLAND-WEST VIRGINIA LINE, ABOUT TWENTY FEET ABOVE R. R. AND TWO HUNDRED FEET FROM IT.

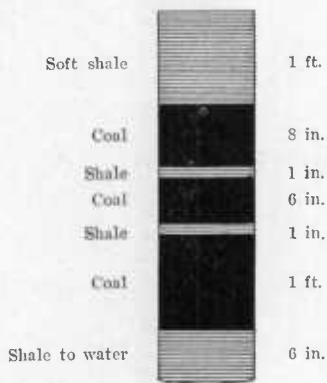

*Upper Freeport ("Sandrock") coal.*—This seam commonly contains from 3 to 4 feet of coal. It is found mainly above water and can be reached to a large extent by drifts. It is found from 165 to 210 feet above the Lower Kittanning coal and caps the Allegheny

*Sections of Upper Freeport Coal.*

DANIEL LEWIS' MINE, ONE MILE NORTHEAST OF SWALLOW FALLS.



W. T. SINE'S MINE, YOUGHIOGHENY RIVER, ONE MILE ABOVE SWALLOW FALLS.

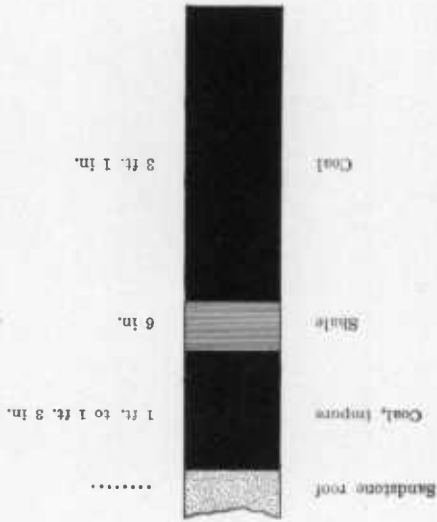

formation. It is locally known under the name of the "Sandrock" seam, and is the representative of the Upper Freeport coal of Penn-

F. R. NETHERKEN'S MINE, WEST OF ROMAN NOSE, FOUR AND ONE-HALF MILES NORTH OF OAKLAND.

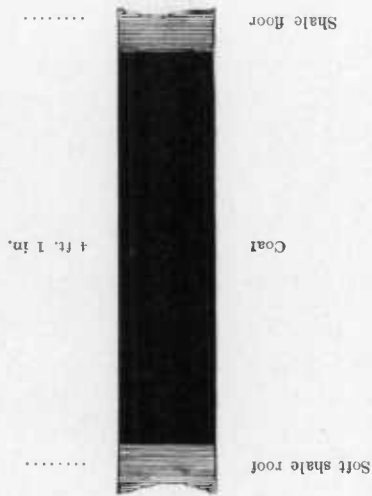

DEVCONON'S MINE, NEAR TEEN GLADE, FOUR MILES NORTH-NORTHWEST OF OAKLAND.

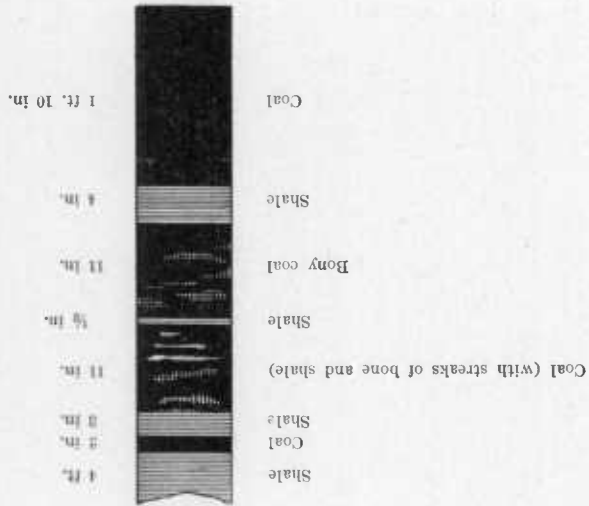

Sylvania. It has already been mined to some extent locally and frequently shows a clean breast of 3 or more feet.

STRIPPING ON GARRETT PROPERTY, ABOVE HERRINGTON CREEK, FIVE AND ONE-HALF MILES NORTHWEST OF OAKLAND.

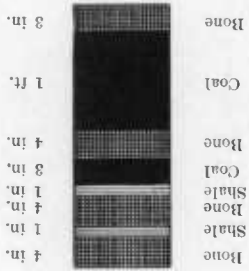

CROSS MINE OWNED BY THOMAS NETIKEN, EAST BANK OF YOUGHIOGHENY RIVER, FOUR MILES NORTH OF OAKLAND.

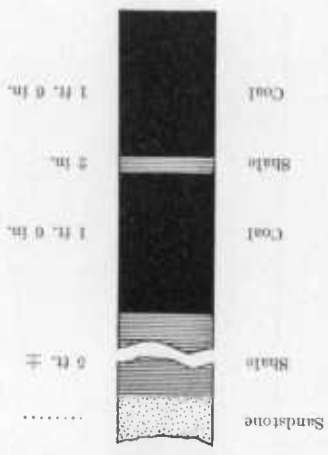

THE CONEMAUGH COALS OF THE UPPER YOUGHIOGHENY BASIN.

The Conemaugh coals have very little development in the Upper Youghiogheny basin as the beds of the Conemaugh formation have suffered extensively from erosion with the result that all except the lower horizons are entirely lacking. Only a single seam has been

found to be prominently developed and the limited areal extent renders it of relatively slight economic importance. The seams below the Bakertown, although present in part, have not been prospected and give no indication of furnishing coal of economic value. The Conemaugh coals are confined to relatively small areas scattered through the central portion of the basin.

McNEIR'S MINE ("DEAL MINE"), MILLER RUN, THREE AND ONE-HALF MILES NORTH OF OAKLAND.

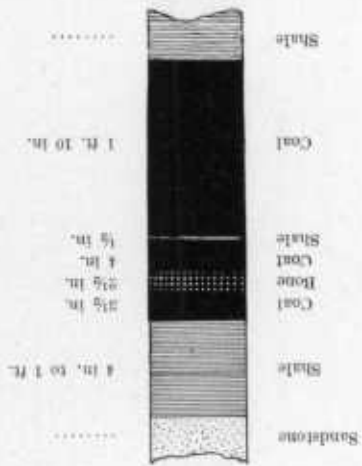

*Bakertown coal.*—This seam covers only a limited area, although the thickness and character of the seam shows it to be a coal of importance in the limited area of its outcrop which, so far as known, is comparatively a small district to the east of Swallow Falls.

THE LOWER YOUGHIOGHENY BASIN.

The Lower Youghiogheny basin is a broad, shallow syncline with a low anticline buried in its western portion. The deepest part of the basin is toward the eastern part of its area, the axis passing not far west of Friendsville.

It contains no Monongahela coals. The Conemaugh coals, although all present, are not, as a general rule, workable.

The Upper Freeport coal is workable by drift from the valleys of Buffalo Run, Laurel Run, Deep Creek, and Mill Run. The larger part of the area of this seam is, however, shaft coal, which can best be reached a short distance up the valley west of Friendsville, or along the railroad anywhere between Selbysport and the Pennsylvania line.

*Section of Bakerstown Coal.*

CHAUNCEY F. KIMMEL'S MINE, ONE MILE EAST OF SWALLOW FALLS.

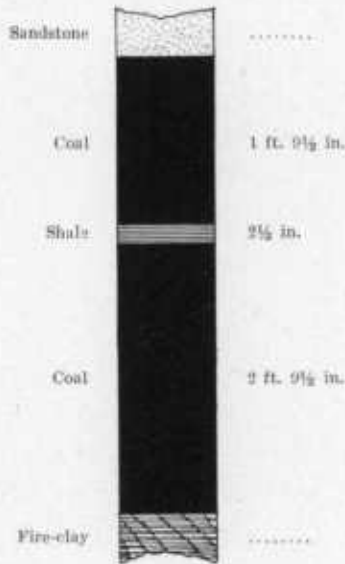

It can probably be reached anywhere within a depth of 100 feet below the railroad. The quality and thickness in this buried portion have never been tested.

The Lower Kittanning coal is shaft coal in the greater part of the area of the basin. There are small areas around the outcrop which can be mined by drift, but only on a small scale, except in the region southwest of Krug, where the entire area can be reached by drift from the valley of the Youghiogheny. Below Friendsville this coal lies at a depth not exceeding 300 feet below the railroad.



## THE POTTSVILLE COALS OF THE LOWER YOUGHIOGHENY BASIN.

The Pottsville coals, as in the other basins, have no economic value. They outcrop around the eastern and southern portions of the district forming the rim of this basin which has its northward and westward extensions in Pennsylvania and West Virginia. The Pottsville coals are thin and practically no attempts have been made to prospect them, so that satisfactory sections are not available. It is not probable that they will be found to possess even local value.

The Mount Savage or Upper Mercer coal has been found at its proper horizon, but the seam is thin and unimportant and no attempt has been made to develop it. Like all of the Pottsville coals, it does not possess any local value.

## THE ALLEGHENY COALS OF THE LOWER YOUGHIOGHENY.

The Allegheny coals occupy the larger part of the Lower Youghiogheny basin and constitute the chief coals of the district. Most of the coals will, however, require slope or shaft mining, the lower coals being deeply buried over much of the district. Numerous local openings have been made in the Allegheny seams and these are generally well distributed along the outcrop. The extent and character of the coals in the deeper portions of the district can only be determined by drill holes. It is probable that valuable local seams may be discovered where these coals can be profitably mined. The lowest seam of the more easterly basins have not been prospected and very little is known regarding them, but it is probable that they are much less important than in the Georges Creek and Potomac basins.

*"Split-six" coal.*—The coal seam corresponding in position with the "Split-six" coal of the lower Georges Creek basin is found about 25 feet below the Lower Kittanning coal of White Rock Run toward the southern end of the basin. The seam at this point has a thickness of about 3 feet, although the coal is somewhat broken by shale partings. The extent of this coal is not known, although it is probably not an important seam.

*Section of "Split-six" Coal.*

OPENING ON WHITE ROCK RUN, THREE MILES SOUTHWEST OF KRUG.

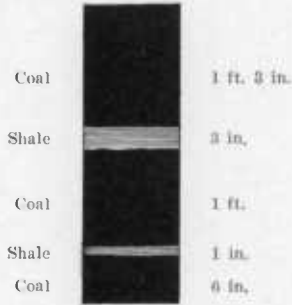

*Lower (and Middle) Kittanning ("White Rock" or "Four-foot") coal.*—This seam is the most widely extended and most important coal in the Lower Youghiogheny basin. This coal has a thickness of from 4 to 6 feet, although the greater thickness is considerably broken by shale and bone coal. This seam occurs between 90 and 150 feet above the base of the formation and from 170 to 210 feet below the top. It has been called the "White Rock" or "Four-foot" seam in the Lower Youghiogheny basin.

*Sections of Lower Kittanning Coal.*

WM. STEELE'S MINE ("CRAZY VEIN"), ONE-HALF MILE EAST OF FRIENDSVILLE.

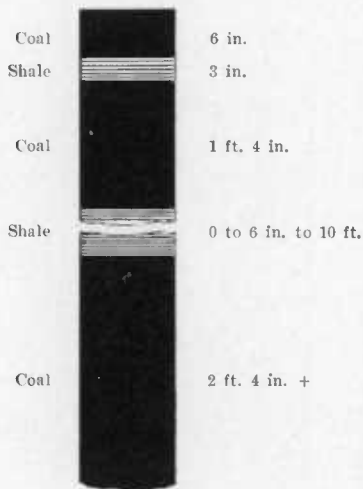

BEAR CREEK LUMBER COMPANY, THREE-FOURTHS MILE SOUTHEAST OF FRIENDSVILLE.

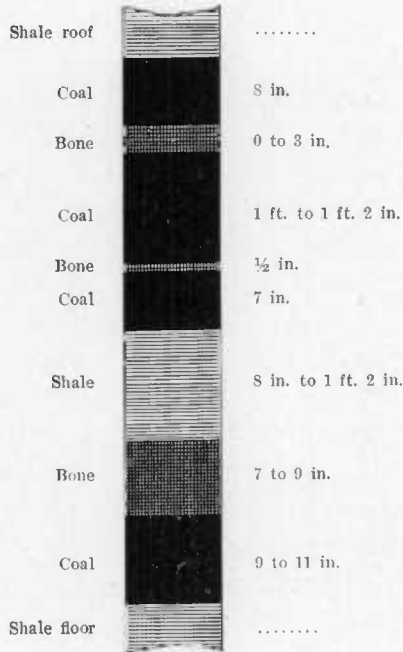

BROWNING AND CUSTER MINE, ONE AND ONE-HALF MILES SOUTHEAST OF FRIENDSVILLE.

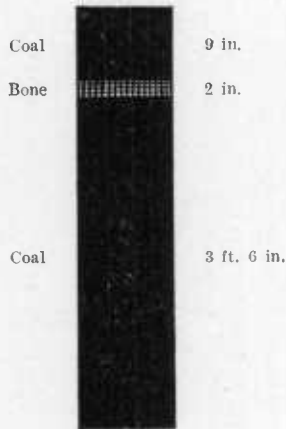

ISAAC MEYER'S MINE, BUFFALO RUN, THREE AND ONE-HALF MILES WEST-SOUTH-  
WEST OF FRIENDSVILLE.

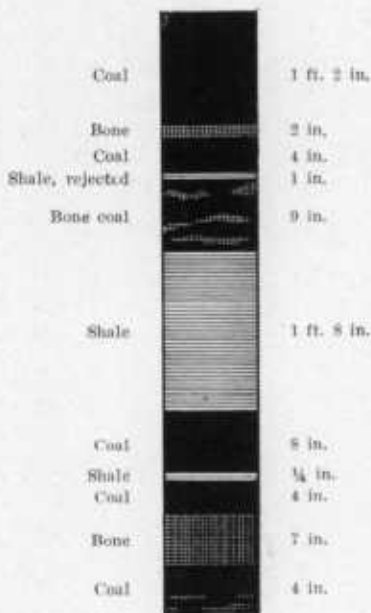

OSCAR FRIEND'S MINE, ONE AND ONE-HALF MILES SOUTHEAST OF FRIENDSVILLE.

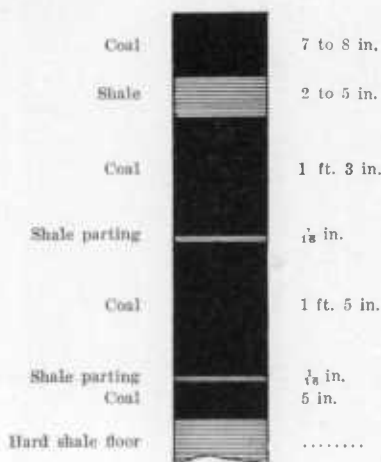

OSCAR FRIEND'S UPPER MINE, ONE AND ONE-HALF MILES SOUTHEAST OF FRIENDSVILLE.

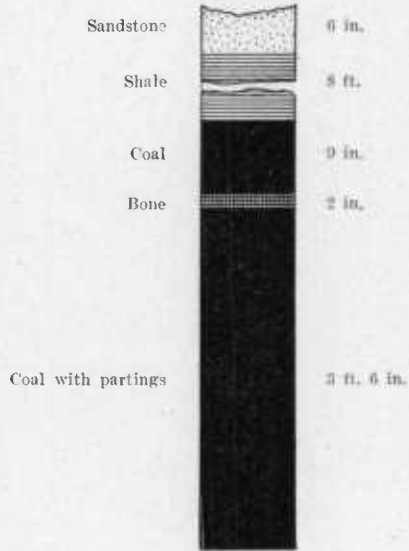

WHITE ROCK MINE, TWO AND ONE-HALF MILES NORTHWEST OF SANG RUN.

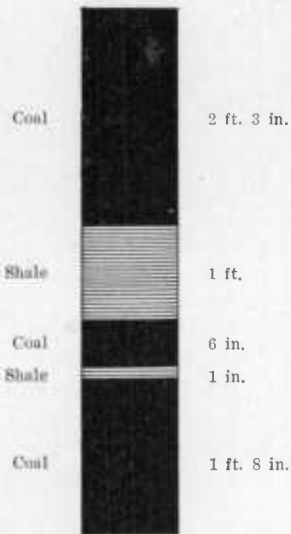

OPENING ON NORTH BANK OF LAUREL RUN AT ITS MOUTH, ONE-HALF MILE ABOVE KRUG.

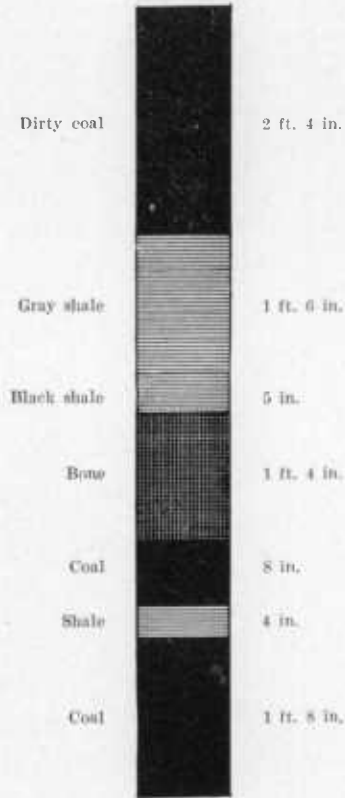

## OPENING ON SOUTH BANK LAUREL RUN, ONE-HALF MILE SOUTH OF KRUG.

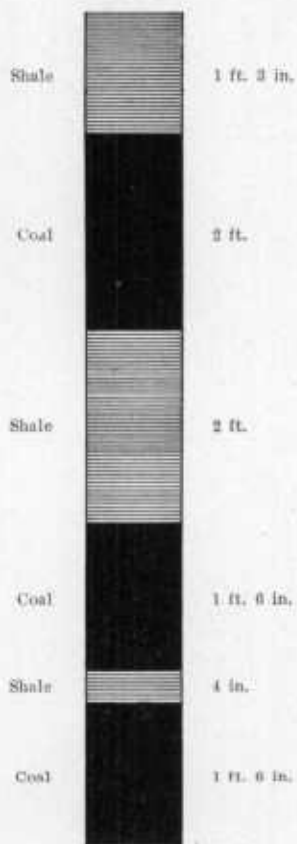

WHITE ROCK MINE, TWO AND ONE-HALF MILES NORTHWEST OF SANG RUN.

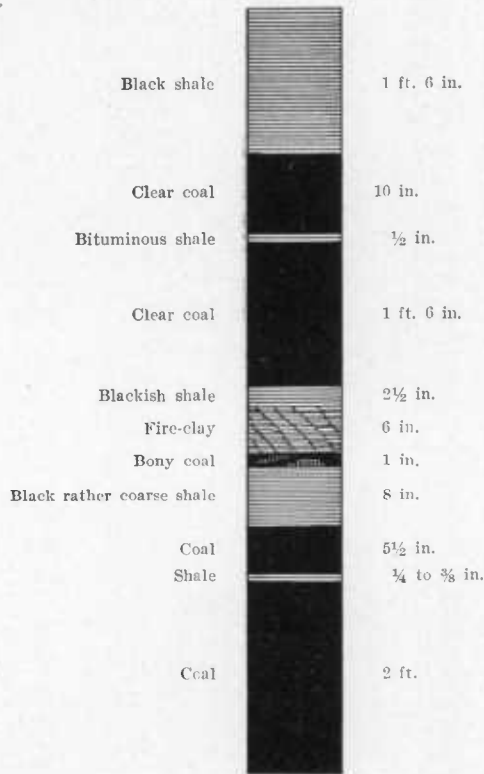

*Lower Freeport coal.*—This seam has been recognized in the northwestern portion of the area, where it has a thickness of somewhat over 2 feet of nearly pure coal. This seam, however, generally possesses little importance in Maryland and will hardly be found to possess more than local value. It occurs from 100 to 145 feet above the top of the Lower Kittanning coal and is commonly found from 35 to 65 feet below the top of the Allegheny formation.



*Sections of Lower Freeport Coal.*

CHRIS. FIKE'S MINE, ONE AND THREE-FOURTHS MILES NORTH OF FEARER.

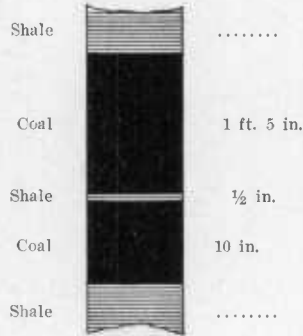

ALBERT FRAZEE'S MINE, ONE AND ONE-HALF MILES WEST OF FRIENDSVILLE.

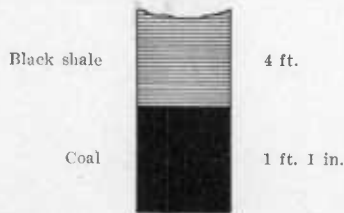

TAYLOR FRIEND'S MINE, BUFFALO RUN, THREE AND ONE-HALF MILES WEST OF FRIENDSVILLE.

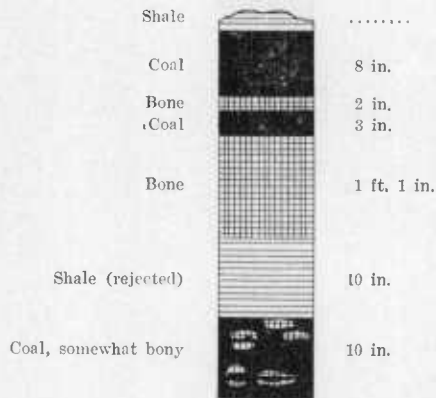

*Upper Freeport ("Sandrock" or "Four-foot") coal.*—This seam is found at the top of the Allegheny formation, or at an interval of 20 to 60 feet above the Lower Freeport and from 165 to 210 feet above the Lower Kittanning coal. It is locally known under the name of

the "Sandrock" or "Four-foot" seam in the Lower Youghiogheny basin. This coal is very persistent and covers a considerable portion of the Lower Youghiogheny basin. Over much of the area it lies below water and its quality and thickness are unknown. In the valleys of several of the creeks it can be reached by drift, especially in the valleys of Buckler Run, Laurel Run, Deep Creek, and Mill Run. This seam could probably be mined successfully by shaft a short distance up to the valley west of Friendsville along the railroad anywhere between Selbysport and the Pennsylvania line. It can probably be reached within a depth of 100 feet below the railroad.

*Sections of Upper Freeport Coal.*

FRAZEE'S LOWER SEAM, ONE HUNDRED YARDS NORTHWEST OF NILES MILL.

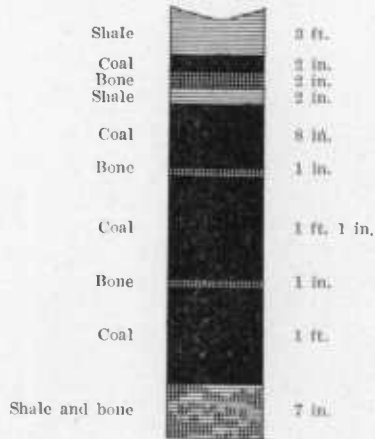

HIRAM FRAZEE'S MINE BETWEEN NILES MILL AND MINERAL SPRING.

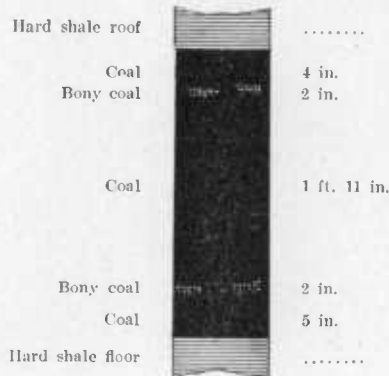

## WM. UMBEL'S MINE, ONE AND ONE-HALF MILES NORTHWEST OF ASHER GLADE.

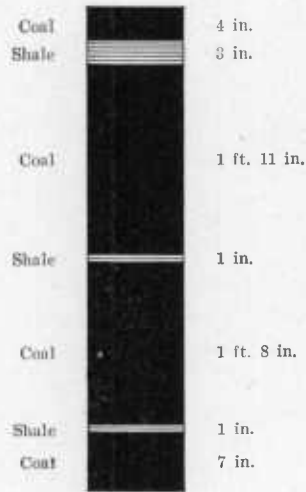
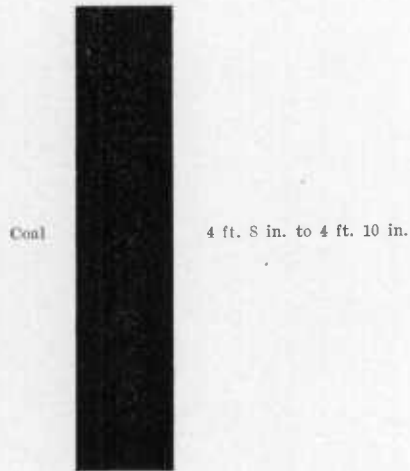
ALBERT ROBERTSON'S MINE, TWO MILES SOUTH OF MARYLAND-PENNSYLVANIA-  
WEST VIRGINIA CORNER.

## THE CONEMAUGH COALS OF THE LOWER YOUGHIOGHENY BASIN.

The Conemaugh coals have very little importance in this region, most of the seams being thin and unworkable even locally. They

cover a much smaller area than the Allegheny coals, being confined largely to the central portion of the basin mainly on the western bank of the Youghiogheny river covering the high lands between the larger tributaries. The Conemaugh coals can mainly be reached by drift where they occur locally of sufficient thickness to warrant their extraction.

GRANT SAVAGE'S MINE, SOUTH BRANCH LAUREL RUN, ONE AND ONE-FOURTH MILES SOUTH OF ASHER GLADE.

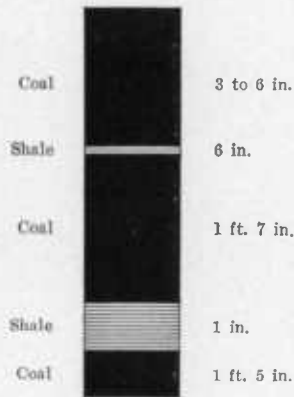

C. FRIEND'S MINE, THREE MILES SOUTHWEST OF FRIENDSVILLE.

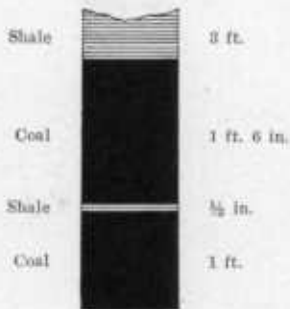

*Mahoning coal.*—This seam occurs from 15 to 20 feet above the Upper Freeport coal and is regarded as the representative of the

Mahoning coal of other areas. It is from 1 to 2 feet in thickness but is more or less broken by shale partings and bony coal. It does not possess more than local value so far as observed.

*Sections of Mahoning Coal.*

FRAZEE'S UPPER SEAM, NILES MILL.

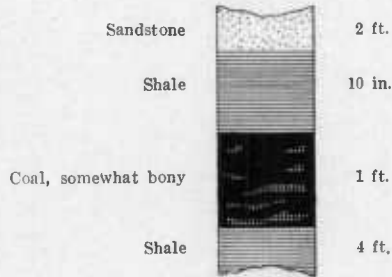

FIRE-CLAY VEIN OF H. M. FRAZEE, NILES MILL.

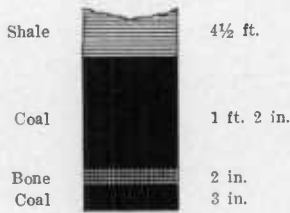

OPENING OF HIRAM FRAZEE AT SELBYSPOUT.

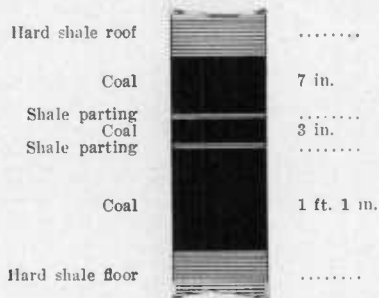

COBERT'S MINE, ONE MILE SOUTH OF FRIENDSVILLE.

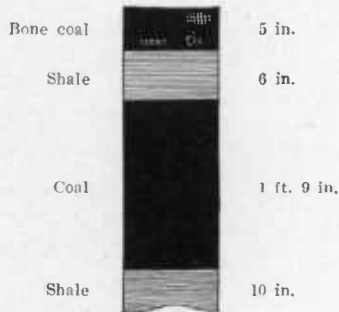

*Brush Creek coal.*—This seam occurs at an interval of about 65 feet above the Mahoning and from 85 to 125 feet above the Upper Freeport coal. It is a persistent coal but is generally less than 2 feet in thickness. It has been prospected very little in the Lower Youghiogheny basin and does not promise more than local value.

*Sections of Brush Creek Coal.*

MINE TWO-THIRDS MILE NORTH OF SELBYSPORT.

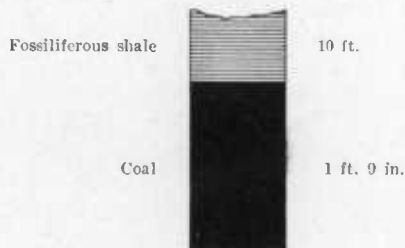

MINE NORTH OF FRIENDSVILLE, WEST BANK OF RIVER.

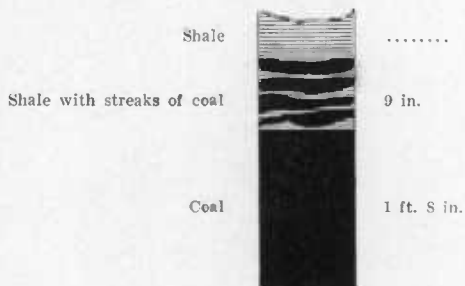

*Bakerstown coal.*—This seam occurs at an interval of from 90 to 135 feet above the Brush Creek coal and has been recognized in the region to the west of Friendsville, where it has a thickness of somewhat over 2 feet. It is very much less important than in the eastern

*Section of Bakerstown Coal.*

CAPT. FRIEND'S MINE, ONE MILE WEST OF FRIENDSVILLE.

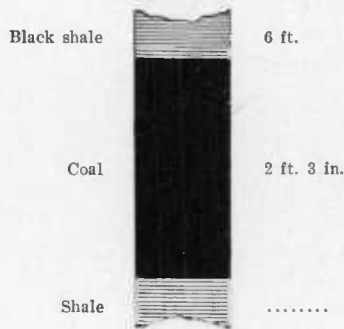

basins and probably does not occur of sufficient thickness to possess much, if any, commercial value. Its area of outcrop is much smaller than that of the lower seams and is confined to the higher areas on the western side of the Youghiogheny river.

*Friendsville (Crinoidal) coal.*—This seam is found about 100 feet above the Bakerstown coal. It covers a very small area in the Lower Youghiogheny basin, being found only in the higher lands in the central portion of the syncline to the west of Friendsville, where it has a thickness of about 18 inches. This coal is the same as the Crinoidal coal of Pennsylvania, but it has been given the name Friendsville in order that the term employed may conform with those of the other coal seams in having a geographical name. This seam does not possess anything more than local value.

*Sections of Friendsville Coal.*

DAVID HERRING'S MINE, ONE AND ONE-HALF MILES SOUTHWEST OF FRIENDSVILLE.

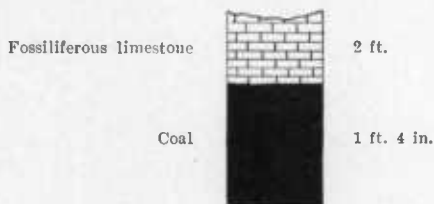

NOY AND AL. FRAZEE'S MINE, THREE AND ONE-HALF MILES SOUTHWEST OF FRIENDSVILLE.

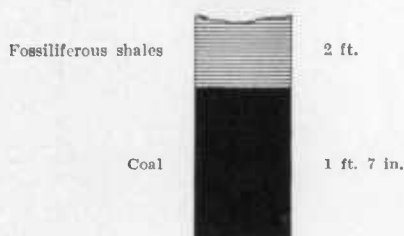

*Franklin (Little Clarksburg) coal.*—This seam occurs about 150 feet below the top of the Conemaugh formation and has been found at only a single locality on the west bank of the Youghioghny river not far from the Pennsylvania line. This coal is much broken by shale layers and does not possess any real economic value.

*Section of Franklin Coal.*

LUCIEN FRAZEE'S MINE, ONE MILE NORTHWEST OF GISE.

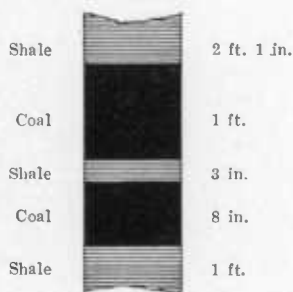

*Little Pittsburg coal.*—This coal is found near the top of the hills a short distance northwest of Friendsville, where it has been locally



mined to some extent, although the coal is of only fair quality, being more or less bony and containing partings of shale. Its position is from 50 to 90 feet below the Pittsburg seam, which is lacking in this region. The very small area of outcrop of this coal does not give it any permanent economic value.

*Sections of Little Pittsburg Coal.*

HARRY RUMBAUGH'S NEW MINE, ONE MILE NORTHWEST OF FRIENDSVILLE.

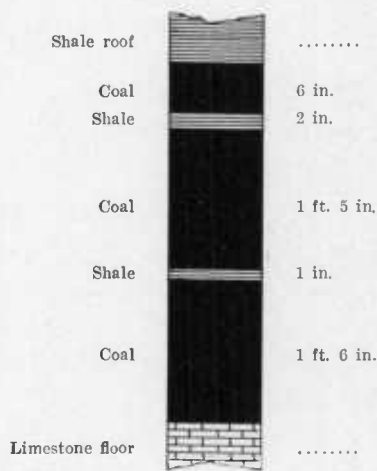

HARRY RUMBAUGH'S OLD MINE, ONE MILE NORTHWEST OF FRIENDSVILLE.  
(Not much cover, now worked out.)

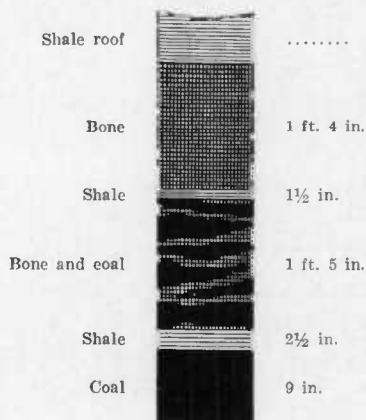

# HISTORY OF THE MARYLAND COAL REGION

BY

B. S. RANDOLPH

---

During the long contest between the English and the French for the possession of the Ohio Valley, the Maryland Coal Region was included in the debatable ground between the English outpost at Wills Creek, now Cumberland, and the French post at Fort Duquesne, now Pittsburg. The danger of sudden attack by Indians or French rendered the country unattractive to settlers. Even after the treaty of Paris in 1763 had confirmed the English title to the area, the Indians continued active until after the revolution when the new government was able to give attention to its western frontier and to protect the settlers.

Few land titles antedate the revolution and the larger number are what are known as "Soldier Lots." These are tracts of fifty acres each, granted by Congress to men who served during the revolution. They, as well as those obtained under the regular State patents, were selected by the grantees and the lines were established largely in accordance with their wishes. This system has resulted in a chaotic mass of oddly shaped tracts, the lines of which it has required a great deal of elaborate litigation to establish on anything like a permanent basis.

There appears to be no certain knowledge of when the coal was first discovered, but with the extended outcrop of so large a seam as the Pittsburg or "Big Vein," occurring so frequently as it does on steep hillsides, it is more than probable that attention was attracted to it as soon as the land was cleared. Tradition points to a locality about a mile north of Frostburg in the valley of Jennings Run, as the situation of the first mine which was worked.

A recently published journal of a journey on horseback, made in 1810, during which the traveler passed over the old Colonial road just south of Frostburg, and stayed over night at what is now known as the "Musselman Farm," owned by the Consolidation Coal Company, makes no mention of the coal, although the writer was evidently a close observer and his notes on other matters along his route are uncommonly full. It is therefore to be inferred that the business was not, as yet, sufficiently developed to attract the attention of the casual traveler.<sup>1</sup>

By 1820 the trade had assumed commercial importance. About this time openings were made in the Pittsburg seam at Eekhart, Pompey Smash, now Vale Summit, and Frostburg and the output transported on wagons to Cumberland where it was loaded on boats for various points on the Potomac River.

The standard boat used for this purpose was of the "flat-boat" type, rectangular in plan with raking ends. The usual dimensions were, length eighty feet, width thirteen feet, depth three feet. Each boat carried 1500 to 1800 bushels of coal with a draft of two feet six to two feet eight inches. It was manned by four men, two operated oars extending, one from each side; one, known as the "headsman," operated an oar extending from the bow and the fourth, known as the "steersman" and Captain, operated an oar extending from the stern of the boat and directed the work of the crew. The boats were built along Wills Creek, the construction being more or less continuous throughout the year. The magnificent white pine forests which at that time existed west of Cumberland furnished an ample supply of boat material.

The coal was unloaded from the wagons and stored in large piles along the river bank awaiting a rise in the water on which it would be possible to run the boats with safety.

When the weather conditions promised a "boating stage" the work of loading the boats was pushed as rapidly as possible, in order to send off all available boats while the water was high enough to admit

<sup>1</sup> See also p. 223.

navigation. The loading gang consisted of four men, two shovellers, one wheelbarrow man and one trimmer on the boat.

Twenty boats have been known to depart in one fleet and as many as forty in one day. Such a departure was an event in the life of the town and usually brought to the river bank crowds of sightseers. There was usually a prolonged boating stage from March until May and frequently a short period, known as the "strawberry" freset in June. Occasionally coal could be taken down in the fall of the year.

The boats were frail affairs and to touch a rock usually meant the loss of the boat and occasionally the drowning of one or more of the crew. They were sold at destination for what they would bring and the crew returned on foot.

There was another boat used for general merchandise, which was a more substantial affair, sharp at both ends. These carried grain and flour down the river and brought back salt and general supplies. They were manned by crews of eight or ten men and propelled by poles, the poles being set against the bottom of the river and the operator walking along the wide gunwale towards the stern of the boat. Coal was not carried on these boats. At the falls above Georgetown these boats passed through locks on the Virginia side of the river and at Harpers Ferry there were rings fixed in the rocks at suitable points to each of which a line was carried in turn and the boat warped up the stream by the crew hauling on the line.

A few years before the close of these boating operations it was found profitable to build another class of boat for the coal trade known as the "sprung rib" boat. These were constructed by a sheathing on frames of hewed timbers bent after steaming. They had round bottoms, sharp prows, and square sterns and were sold at tidewater to parties engaged in the transportation of wood from the tidal portions of the Potomac River to Washington and other cities.

The boating was participated in very generally by all classes. Farmers and men from other occupations were in the habit of building a boat or two during the winter, loading it and running it

through with the spring high water as a means of obtaining ready cash.

Market prices for coal ranged from seven to eight cents per bushel at Cumberland, twenty-eight to thirty-three cents at Williamsport, thirty-five to forty-five at Harpers Ferry, and fifty to sixty at Georgetown. Wages of boatmen varied from \$10 to \$12 per trip and \$15 to Georgetown on the "push boats" which were brought back.

This method of transportation gradually disappeared in the face of railroad competition and ceased entirely on the completion of the canal to Cumberland.

The Baltimore and Ohio Railroad was completed to Cumberland in 1842 and for some time coal was brought to Dam No. 6, to which point the canal had been completed, and there loaded on canal boats for shipment to tide-water.

The Mt. Savage and Cumberland Railroad was built in 1844 from Cumberland to Mt. Savage by the Maryland and New York Mining Company and the line from Cumberland to Eckhart, now known as the Eckhart Branch of the Cumberland and Pennsylvania Railroad, was built a few years later by the Maryland Mining Company.

This Maryland Mining Company, chartered in 1828, was the first chartered company in the region. It operated what is now known as the Eckhart Mine and, until the completion of its railroad, sent its product to Cumberland by wagon. Upon the completion of the railroad to Mt. Savage, tramways were built from the mines north of Frostburg to Mt. Savage and the coal was then transported in mine cars and loaded on the railroad cars at the latter point.

About this time an interesting experiment was made by the construction of a flume or sluiceway from Vale Summit to Clarysville on the Maryland Mining Company's Railroad for the transportation of coal by a stream of water.

Owing to its fragile nature the coal was so much damaged by this operation that the scheme was promptly abandoned.

A tramway was built from Clarysville to Lonaconing by way of Vale Summit which appears to have been used exclusively for the

transportation of pig iron from the furnaces of the Georges Creek Coal and Iron Company at the latter point.

In 1850 the Frostburg Coal Company had extensive coking yards at Mt. Savage and the practice of coking the coal was extensively followed by this and other companies in the region. This coke was used by the local furnaces, at that time in operation, and was also shipped east for locomotive use. Mr. Robert G. Rankin in 1855 states that "The opinion seems to prevail among northern railway operators, that this (Georges Creek) coal is only fitted for northern engines when it is coked; but when prejudice gives way to fair investigation and experiment, *it is confidently believed that the crude Cumberland coal will be found to contain more combustible matter, pound for pound, than the coke.*"

The companies in business and shipping by rail in 1850 were the Frostburg Mining Companies and the Alleghany Mining Company, loading at Mt. Savage; and the Maryland Mining Company and the Washington Coal Company, loading at Eckhart on the Maryland Mining Company's Railroad.

The freight rate to Cumberland of three cents per ton-mile remained unchanged from the opening of the roads, while the rate from Cumberland to Baltimore suffered several heavy reductions from \$3.66 in 1845-6 and \$2.64 in 1846-7 to \$2.46 in 1849. Upon the completion of the canal to Cumberland this rate was further reduced to \$1.75 to be advanced in a few years to \$2.25.

The permanence of the rate west of Cumberland as was to be expected aroused no small amount of feeling among the shippers and numerous efforts were made to obtain a reduction, the movement even going so far as a petition to the Legislature for statutory relief. Additional evidence of this friction exists in the passage of a bill in 1849 providing for an equitable distribution of ears to all shippers.

Mining rate was twenty-eight cents in the Pittsburg seam and fifty-five cents in the smaller seams, a difference well-calculated to keep the latter out of the market.

The Pittsburg seam, known generally as the "Big Vein," was being rapidly bought up, in some cases largely as a speculation. Much of it was obtained as low as ten dollars per acre.

In 1852 ownership was distributed about as follows:

Cumberland Coal & Iron Co. (successor to Maryland Mining Co.)	6000	acres.
Georges Creek Coal and Iron Co.	3000	"
Smaller Companies about Frostburg	2500	"
Baltimore capitalists	2000	"
Original owners	4500	"
	<hr/>	
	18,000	acres.

Upon the completion of the Baltimore and Ohio Railroad to Piedmont, W. Va., in 1853 the Georges Creek Coal and Iron Company built a railroad up the valley of Georges Creek to Lonaconing and abandoned its tramway to Clarysville. Its operations had previously been confined to the manufacture of iron, but it now became a shipper of coal also.

The Mt. Savage and Cumberland Railroad was extended to Frostburg in 1852 and at that time recognized as its shippers the Frostburg Mining Company, Borden Mining Company, Withers Mining Company, Parker Vein Coal Company and the Chesapeake Coal Company. In 1857 it was extended to Lonaconing and in 1864 the Georges Creek Coal and Iron Company's road from Lonaconing to Piedmont was purchased and consolidated under the charter of the Cumberland and Pennsylvania Railroad.

Little effort appears to have been made up to this time looking to consolidations among the various operators, with the exception of the Cumberland Coal and Iron Company and the Georges Creek Coal and Iron Company the various properties embraced tracts of a few hundred acres only.

In 1860 an act was passed incorporating the Consolidation Coal Company of Maryland and in 1864 the Company was organized, embracing the properties of the "Ocean Steam Coal Company," "Frostburg Mining Company," and "Mt. Savage Iron Company,"

which latter owned the Cumberland and Pennsylvania Railroad Company. These properties included a total of nine thousand acres of surface about four thousand acres of which was underlain by the Pittsburg seam. This movement towards consolidation is generally credited to Mr. William H. Aspinwall of New York, who, with his associates, had recently purchased a tract extending across the basin in the neighborhood of Squirrel Neck and Wrights Run, and had organized the Ocean Steam Coal Company.

A further move toward consolidation was made in 1869 when the following circular was issued, which, incidentally, draws an interesting picture of the coal trade conditions.

TO THE STOCKHOLDERS OF THE COMPANIES MINING CUMBERLAND  
COAL IN ALLEGANY CO., MARYLAND.

AN EXPERIENCE OF TWENTY-FIVE YEARS HAS CONVINCED MANY OF THE MOST PRACTICAL AND SAGACIOUS PERSONS, WHOSE INTERESTS HAVE BEEN IDENTIFIED WITH THE DEVELOPMENT OF THE CUMBERLAND COAL MINES, THAT THOSE INTERESTS CAN ONLY BE MADE REASONABLY REMUNERATIVE BY A COMPLETE CHANGE IN THE SYSTEM OF MANAGEMENT. THE TOTAL PRODUCT OF 1708 TONS IN 1842 HAS BEEN INCREASED, BY THE LEGITIMATE DEMANDS OF TRADE, TO 1,330,443 TONS IN 1868, WITH A PROSPECT OF 1,500,000 TONS IN 1869, AND YET, OF THE IMMENSE CAPITAL WHICH HAS BEEN INVESTED IN ALLEGANY COUNTY, IN COAL PROPERTY, HOW LARGE A PROPORTION HAS BEEN SWEEPED AWAY, AND OF THAT NOW REPRESENTING THE MINING INTERESTS HOW INSIGNIFICANT IS THE PROPORTION WHICH, EVEN OCCASIONALLY, MAKES ANY RETURN TO THE PROPRIETORS. THREE REASONS MAY BE GIVEN TO EXPLAIN THESE UNSATISFACTORY RESULTS. *First*, REMOTENESS FROM OUR PRINCIPAL MARKETS, WITH INSUFFICIENCY AND HIGH COST OF TRANSPORTATION THERETO; *Second*, HEAVY EXPENSES OF MULTIPLIED ADMINISTRATION, AND *Third*, RUINOUS AND, UNDER EXISTING CIRCUMSTANCES, UNCONTROLLABLE COMPETITION.

THE FIRST OF THESE OBSTACLES WOULD INEVITABLY SUBSIDE, IF NOT DISAPPEAR, UNDER A SYSTEMATIC AND UNIFIED APPORTIONMENT OF PRODUCTION TO DEMAND; THE SECOND AND THIRD WOULD OBVIOUSLY VANISH BY THE SUBSTITUTION OF A SINGLE MANAGEMENT, IN THE COMMON INTEREST, FOR THE TWENTY-ONE SEPARATE ORGANIZATIONS WHICH, WITH THEIR COMPLICATED AND EXPENSIVE MACHINERY, NOW ABSORB THE MODICUM OF PROFIT WHICH IS LEFT TO THE OWNERS OF THE MINES.

FIVE OF THE LARGEST COMPANIES HAVING, WITH OTHERS, TRIED FOR YEARS,



BUT IN VAIN, TO REMEDY THE EVILS ABOVE ADVERTED TO, BY HARMONY OF ACTION, HAVE AT LENGTH DETERMINED TO FIND, IF PRACTICABLE, A SOLUTION OF THE PROBLEM BY UNITING THEIR PROPERTIES UNDER ONE ORGANIZATION, PERMANENT AND HOMOGENEOUS. A SUITABLE AGENT HAS BEEN SELECTED TO INVESTIGATE THE RELATIVE AREAS AND VALUES OF THEIR RESPECTIVE COAL LANDS, PRELIMINARY, IT IS HOPED, TO THE ADOPTION OF AN EQUITABLE BASIS OF INCORPORATION. THESE FIVE COMPANIES ARE NOW MOVING IN PERFECT ACCORD TOWARD THAT OBJECT, AND HAVE ESTABLISHED A JOINT COMMITTEE ON CONSOLIDATION. WITHIN A MONTH IT IS HOPED THAT THEY WILL BE PREPARED TO PROCEED TO THE CONSIDERATION OF SUCH A BASIS. TO THIS END IT IS EARNESTLY DESIRED THAT AS MANY COMPANIES NOW OPERATING IN THE CUMBERLAND COAL REGION OF ALLEGANY COUNTY SHOULD UNITE IN HAVING THEIR LANDS SURVEYED AND APPRAISED; OR, IF NOT THAT, THAT THEY WILL, AT LEAST, APPOINT A REPRESENTATIVE, OR MORE THAN ONE AND NOT MORE THAN THREE, TO MEET WITH THE JOINT COMMITTEE, AND DISCUSS WITH THEM THE BEARINGS OF THIS SCHEME ON THEIR VARIOUS INTERESTS. STOCKHOLDERS ARE EARNESTLY REQUESTED TO PRESS THIS IMPORTANT SUBJECT UPON THE CONSIDERATION OF THEIR DIRECTORS.

COMMUNICATIONS MAY BE ADDRESSED TO EITHER OF THE OFFICERS OF THE JOINT COMMITTEE, WHOSE NAMES ARE AFFIXED, REPRESENTING THE AMERICAN, BORDEN, CONSOLIDATION, CUMBERLAND COAL & IRON, AND HAMPSHIRE & BALTIMORE COMPANIES.

ALLAN CAMPBELL (Prest. C. C. & I. Co.),  
Chairman Joint Committee, 90 Broadway.

JAMES S. MACKIE (Vice-Prest. Consol. Coal Co.),  
Secretary Joint Committee, 71 Broadway.

NEW YORK, May 31, 1869.

The "suitable agent" selected "to investigate the areas and values" was Mr. J. T. Hodge, a Mining Geologist of standing and experience. He, with several assistants, spent six months in the work submitting his report under date of November 18, 1869. He appears to have made a very complete study and, with the exception of one or two of the properties not in sympathy with the movement, the report contains very full information. The tabulated summary shows following facts:

## TABLE OF PROPERTIES

CONTAINING THE GREAT COAL BED OF THE CUMBERLAND BASIN.

Name	Acres of coal	Acres exhausted	Acres remaining	Tons ship'd to date
Withers Mining Co.....	....	...	....	27,792
New York Mining Co.....	650?	...	650?	4,100
Alleghany Mining Co.....	391	100	291	614,843
Borden Mining Co.....	762	227	535	1,388,463
Cumberland Coal & Iron Co.....	4900	600	4300	3,130,282
Consolidation Coal Co.....	3323	275	3048	1,489,609
Wright Farm .....	484	...	484	.....
Blaen Avon Coal Co.....	57	...	.57	.....
Johnson [now Shaw] .....	72	...	.57	.....
Midlothian Coal & Iron Co.....	60	13	47	.....
Koontz .....	500?	...	500?	.....
Hampshire & Balto. Coal Co.....	303	143	160	1,170,483
Georges Creek C. & I. Co.....	1550?	200	1350	1,144,260
Maryland, or Savage Mt. Coal Co....	500?	5	495	28,250
National Coal Co.....	85	7	78	41,989
Central Coal M. & M. Co.....	793	235	558	1,289,473
Atlantic & Georges Creek Coal Co....	54	30	24	163,858
American Coal Co.....	1119	274	845	1,508,065
Davis & Rieman .....	144	...	144	.....
Piedmont Coal & Iron Co.....	140?	70	70?	397,967
Barton Coal Co.....	180	38	142	211,498
Potomac Coal Co.....	94	58	36	322,579
Swanton Mining Co.....	140?	68	72?	371,664
Georges Creek Mining Co.....	200?	35	165?	194,094
Franklin Coal Co.....	300?	122	178?	672,248
S. P. Smith [Hoy tracts].....	203	25	178	.....
Humbertson Tract.....	49	...	49	.....
Jacobs Tract .....	...	...	24?	.....
Hixenbaugh Tract .....	...	...	100?	.....
Percy Tract [Boston owners] .....	...	...	80?	.....
Kilte Tract .....	...	...	25?	.....

---

 14,797

The report was very unsatisfactory to a number of the parties interested and appears to have put an end to the "perfect accord" with which the signatory companies were moving at the date of the circular. The scheme failed utterly with the exception of the acquisition of the property of the Cumberland Coal and Iron Company by

the Consolidation Coal Company which took place in March, 1870, and included the railroad from Cumberland to Eckhart.

This brought to the Consolidation Coal Company more than half the coal lands of the region and all of the railroad facilities. The property of the Alleghany Coal Company was acquired in 1872 and the coal under the Wright Farm a few years later, practically completing the holdings of this company as they now exist.

Up to this time the only outlet for the product of the region had been the Baltimore and Ohio Railroad and the Canal, but in 1872 the Bedford and Bridgeport Railroad was constructed in the interest of the Pennsylvania Railroad, and by means of a traffic arrangement with the Huntington and Broad Top Railroad the facilities of the former road were brought to the Maryland and Pennsylvania state line of Ellerslie, and the construction of a line from Kreigbaums to the State Line provided an outlet to the Pennsylvania system.

The Pennsylvania Railroad was thus brought into direct competition with the Baltimore and Ohio Railroad for the business of the region. To meet this condition the stock of the Consolidation Coal Company, the largest shipper, was largely acquired by the Baltimore and Ohio Railroad and friendly interests, and in 1877 a full board of directors, friendly to this interest was elected with Mr. Chas. F. Mayer as president.

The connection with the Pennsylvania Railroad was thus rendered ineffective and in 1880 the Cumberland and Georges Creek Railroad, from Cumberland to Lonaconing, was built in the interest of this road and the American and Maryland, and subsequently, the New Central Companies abandoned their connections with the Cumberland and Pennsylvania Railroad and confined their subsequent shipments to the Pennsylvania route. A few years later connection was also made with this road by the Georges Creek Coal and Iron Company without abandoning their facilities on the Cumberland and Pennsylvania Railroad.

Previous to the year 1890 the Pittsburg seam, known locally as the "Big Vein," had supplied practically all the tonnage of the

region. Numerous efforts had been made to work the other seams with occasional temporary success which, however, had not resulted in the development of any operations of importance.

The first of these efforts to attain permanent success was that of the Franklin Coal Company in working the "Tyson" or "Sewickly" coal, situated some sixty feet above the Pittsburg seam. On the property of this company this coal is about six feet high with no slate. The coal from this seam was successfully mixed with that from the Pittsburg seam for a number of years. With the gradual exhaustion of the Pittsburg bed the demand for other sources of supply became imperative and large amounts of money were spent in prospecting. As on the Franklin property, some success was encountered with the beds above the Pittsburg by mixing with the product of the latter, but all the companies having any considerable business to provide for have been obliged to secure properties in other regions in order to supply the demands.

The excessive activity in the coal business which originated about the year 1901 has stimulated the development of the lower seams and a number of operations in these seams are being successfully worked, notably along the West Virginia Central and Pittsburg Railway, where the freight rates are more favorable to the competition with the coal from other sources, which must be met.

#### LABOR.

The earliest mining required a small number of men which were readily recruited from the neighborhood. The increased demand following the completion of the Baltimore and Ohio Railroad and the Chesapeake and Ohio Canal, to Cumberland, was largely supplied from among the laborers who had assisted in the construction of these works. These men were principally Irish, who, at that time, were coming to this country in large numbers owing to the famine and the disturbed political conditions in their own land.

As the workings became more extended and more skill was required in their prosecution, men were brought over from the mining dis-

tricts of Scotland and Wales as foremen. These were naturally followed by their friends and acquaintances from the regions they had left and these two nationalities have supplied the bulk of the labor.

As the number of men increased the usual friction between employees and the operators manifested itself. For many years each establishment acted independently in the matter of wage agreements and strikes were numerous though usually confined to one or two properties.

The growth of the Knights of Labor in the later "seventies" included this region and by 1880 the organization was well established. As there was no unity of action among the operators, the control of the properties practically passed into the hands of the employees, even down to the smallest details of discipline. This system ultimately caused the operators to enter into a combination which, in 1882, reduced the mining rate from sixty-five to fifty cents per ton, and fought the resulting strike as a unit.

This strike lasted six months and was bitterly contested. The Consolidation Coal Company introduced outside labor when the strike was about three months old, but the movement was so managed that there was no bloodshed.

The men brought in at this time were mostly Germans, Swedes, and Slavs who had had no experience in mining, but after a few weeks training under the foremen who remained loyal to the Company, they produced a very satisfactory grade of coal. A few of them are still in the region, but an interesting peculiarity, especially of the Germans and Swedes, was their tendency to purchase farms and embark in agriculture as soon as they had accumulated a little money in mining.

At the close of the strike the men went to work on the operators' terms.

Since the close of this strike the operators have continued to act as a unit on all matters affecting wages.

The organization of the Knights of Labor died out and was re-

placed in 1886 by another organization under the name of the Federation of Miners and Mine Laborers.

This revival resulted in a strike of two months duration in which the men demanded an increase of ten cents per ton on the rate of forty cents, then prevailing, but returned to work without securing any concessions.

In 1894 the condition of the trade made a reduction in wages necessary and an effort was made to effect this by a compromise with the men. A meeting was arranged in Cumberland to which each mine was requested to send delegates. The meeting was duly held, attended by delegates from each mine and by a representative from each employer. The situation was explained by the employers' representatives and the necessity for the reduction, in order to meet the competition of other regions, was fully set forth. The delegates disclaimed any authority to accept or reject the proposed reduction, but offered to report to their constituents and notify the operators, through the Superintendents, what their action would be. Cordial expressions of good will were made by both parties and the best feeling prevailed. The delegates reported as agreed upon and with the exception of two or three mines, notified the Superintendents that the reduction from fifty to forty cents per ton for mining would be accepted to last until such time as the market conditions would justify a return to the rate of fifty cents. Work was continued throughout the region at the new rate and the prospects for a peaceable solution of the question were all that could be asked.

A few weeks afterwards, Mr. W. B. Wilson, an officer of the United Mine Workers appeared in the region and after some time persuaded the men to declare what was called a "suspension" until such time as the stoppage of the shipments should cause an advance in the market price of coal and enable the operators to pay a higher price. The fallacy of this idea was soon apparent since the stoppage had no effect on the market prices as practically all the business had been contracted for at prices based on the rate for which the men had already agreed to work. With the exception of

the Eckhart, Alleghany and Hoffman mines of the Consolidation Coal Company all the mines in the region suspended operations. The men employed in these mines held meetings and resolved that having given their promise to work at the forty cent rate they were in honor bound to do so.

The usual methods were employed to induce the men at work to join the strike. Large bodies of strikers thronged the roads as these men went to work each morning. The efforts, confined at first to good humored bantering, gradually become more ill-natured and threatening until the Sheriff felt obliged to ask the Governor for troops. The fourth and fifth regiments of the Maryland National Guard responded, the latter remaining until relieved by the first regiment. Under the protection of the military, the work proceeded at the mines not on strike, and after some three weeks of this protection all the mines throughout the region resumed.

This was followed by a practical abandonment of anything like organization by the men, until 1899 when it was again revived under the leadership of Mr. William Warner of the United Mine Workers of America.

The first step was an address purporting to come from the employees, independent of the organization, asking for a meeting with the operators similar to that held in 1894. So many of the operators still cherished feelings of resentment at the failure of their employees to carry out their promises in 1894, that it was impossible to arrange such a meeting, and in its stead a circular, addressed to the employees and signed by all the operators was issued and posted at the mines. This had little effect on the conservative element and was used by the agitators to stir up the men with the statement that the operators considered it beneath their dignity to treat with the men. The agitation proceeded apace with the avowed object of obtaining an advance in the mining rate from forty-five to fifty-five cents per ton. In February, 1900, the operators notified the employees that after the first day of April the rate would be advanced to fifty-five cents per ton. The demand of the men was then ad-

vanced to sixty cents and on March 31 the organization was considered strong enough for a demonstration.

A mass meeting was called at Lonaconing on that day and with the exception of about forty per cent of the employees of the Consolidation Coal Company, the employees of all the operators failed to report for work. The Consolidation Coal Company suspended eighty men who had taken part in this movement and its employees struck to secure their reinstatement. This being a question of discipline and not one of wages could be taken up by the officers of the affected company independent of the other employers and through the agency of some of the business men of Frostburg arrangements were made for Mr. C. K. Lord, President of the Consolidation Coal Company to meet a committee of his own employees in Baltimore, but before this could be carried out the authorities of the United Mine Workers called a general strike in which the lesser issue was obscured.

This strike lasted four months and involved every property in the region. The anxiety to work at the wages offered was so great that continual activity on the part of the violent element resulted. Assaults were numerous and a number were injured but no lives were lost. A special session of court was called and twenty of those most active in these assaults were convicted and sentenced for periods ranging up to six months in the House of Correction.

The men returned to work without obtaining any concessions. Since this strike the United Mine Workers have maintained a few lodges with small and uncertain membership and have had paid representatives in the region for considerable periods, but they are not recognized in any way by the employers.

Throughout the foregoing paper continuous effort has been made to limit the sources of information to printed records and first hand statements in all important matters. The information concerning river shipments was obtained from Mr. George Hughes of Cumberland who was actively engaged in the work. Reports of experts and annual reports of Presidents of the various corporations have been relied on principally for the remaining matter.



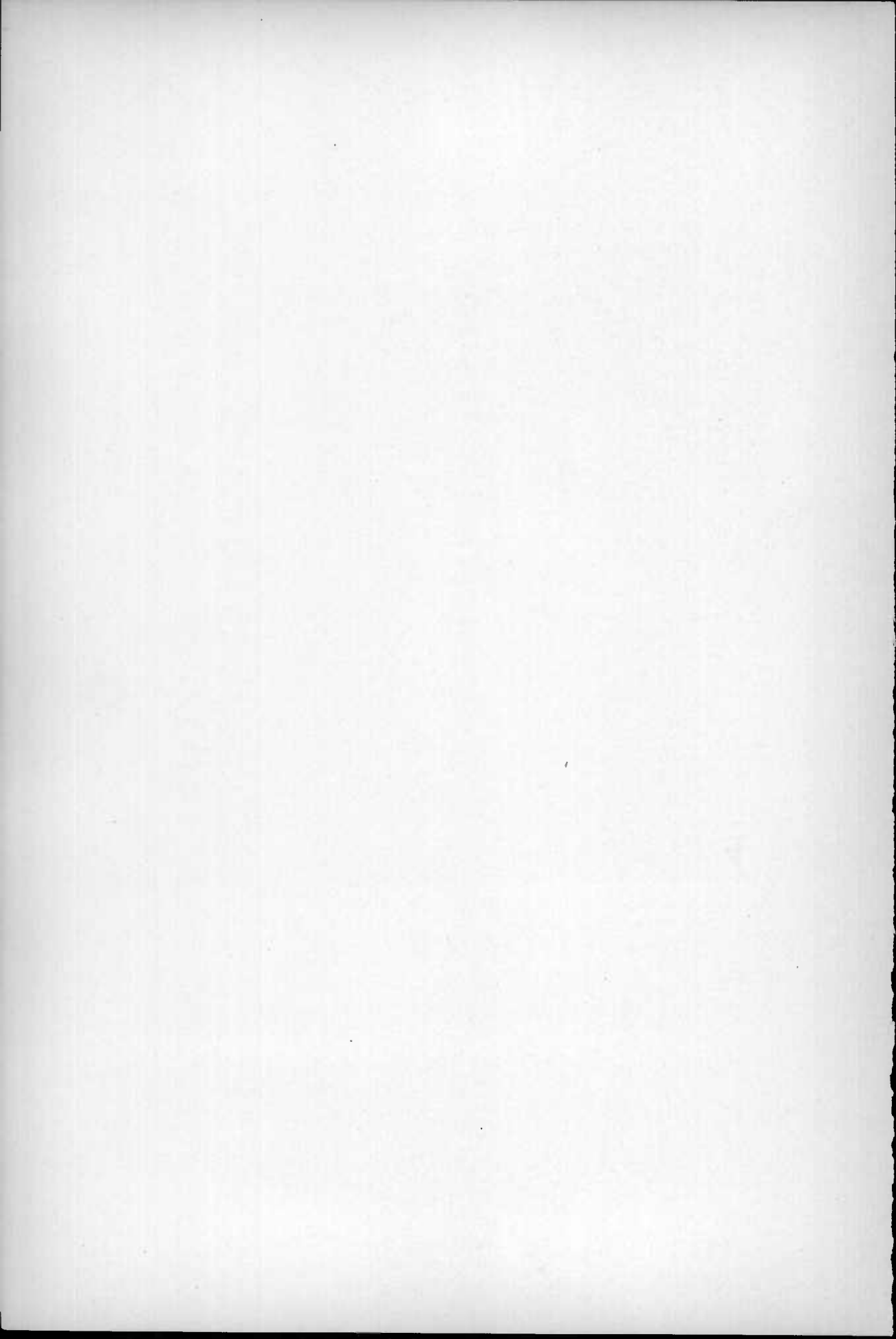

# THE COAL MINES OF MARYLAND

BY

N. ALLEN STOCKTON

---

## INTRODUCTORY.

The coal mines of Maryland, as already shown, are confined to the two western counties of the State, Allegany and Garrett, and occur in five synclinal troughs, the most important of which lies on a narrow strip of territory on either side of the valley of Georges Creek known as the Georges Creek Coal Basin.

Second in importance to the Georges Creek valley as a coal-mining region is the southwestern extension of the Georges Creek Coal Basin along the North Branch of the Potomac river on the border line of the States of Maryland and West Virginia. The mines in this region in many instances are in the State of Maryland while the coal from them is brought to and shipped by the West Virginia Central Railroad in West Virginia. This region is known as the North Potomac Coal Basin.

Three other synclinal basins containing the coals of the Allegheny formation are found in Garrett county, but the development of these areas is as yet limited to openings intended only to supply coal for local domestic uses.

## THE GEORGES CREEK-UPPER POTOMAC BASIN.

Throughout the Georges Creek coal region the Pittsburg seam, "Big Vein," or "Fourteen-foot Vein" as it was also formerly called, has furnished and still supplies the greater part of the coal produced, and the coal from this seam has a quality for steam-producing pur-

poses and a thickness of bed equal if not superior to the best other "steam" or semi-bituminous coals in the world.

In addition to the Pittsburg seam or "Big Vein" of the Georges Creek valley, the lower coal beds of the Allegheny, or Lower Productive Coal Measures of Pennsylvania, appear at the surface at the southern end of the basin and are now extensively mined from Moscow to Westernport and Bloomington, and still farther to the southwest along the west bank of the Potomac river on the eastern border of Garrett county.

At Barrellville, a few miles beyond the northeastern extremity of the Georges Creek region proper, the coal beds of the Allegheny coal series are operated and shipped to the Cumberland and Pennsylvania Railroad over a branch railroad owned and operated by the Cumberland Basin Coal Company.

Two coal beds of the Monongahela series lying above the Pittsburg seam are also worked in the vicinity of Frostburg, Lonaconing, and Barton.

For 62 years the coal beds of the Georges Creek region (principally the "Big Vein") have been operated, and in that period, extending to the end of the year 1903, 110,249,945 tons of coal have been produced. The yearly output of coal from the Georges Creek region increased from 1708 tons in 1842 to 4,350,954 tons in 1902, when the high-water mark of coal production in that region was reached. In 1903 the production fell off somewhat, the output of the region for that year decreasing to 3,977,130 tons.

The coal of this district is known commercially as "Georges Creek coal." Sometimes it is called "Cumberland coal," and formerly it was often sold under the name of "Piedmont coal."

#### THE PITTSBURG SEAM, OR "BIG VEIN."

The "Big Vein," which seems to correspond in geological horizon to the Pittsburg coal bed of Pennsylvania, at one time spread over the greater part of western Maryland, western Pennsylvania, and

West Virginia, as well as other western and southern States, is now nowhere to be found in the State of Maryland except in or on either edge of the narrow synclinal basin about 20 miles long, extending from Mount Savage to Westernport, and in two small detached areas in the Potomac valley. Through nearly the middle of this basin Georges Creek has cut its way from Ocean southward to the Potomac river, and Jennings Run has eroded its bed from Frostburg northward to Mount Savage, and to compensate in some measure for the wholesale destruction of incalculable wealth the erosive action of the waters has made such natural conditions through these valleys that what remains of this coal bed has been generally cheaply and easily mined.

Near the northern end of the basin the "Big Vein" underlies the town of Frostburg, but close to the northern, eastern, and western borders of the town erosion has brought it to the surface, so that its outcrop is entered and mined by drifts and slopes in the mines of the Consolidation, Union, and other mining companies. From Frostburg to Ocean mine No. 1 of the Consolidation Coal Company, a distance of four miles, the "Big Vein" is beneath the surface and outcrops only on the edge of the basin, the greatest width of which is three and a half miles. At Ocean mine No. 1 Georges Creek has cut through to this coal bed, and from Ocean southward to Westernport that creek and its tributary streams have eroded their courses deeper and deeper into the underlying measures exposing one after another of the lower Conemaugh and Allegheny series of coal beds, leaving numerous detached knobs of "Big Vein" coal of greater or less area, which outcrop high up on the hills on both sides of the Georges Creek valley.

*Thickness of the "Big Vein."*—The "Big Vein" coal bed of Georges Creek was formerly called the "Fourteen-foot Vein" from the usual thickness of the seam at the southwestern end of the basin near Piedmont, West Virginia, and Westernport, Maryland. At this end of the basin the coal is thickest and its thickness gradually decreases toward the northeast. At Frostburg the height of the coal

is not more than 8 or 9 feet, and at the latter point a parting of shale or "slate" of considerable thickness appears between the upper and lower benches of the coal and extends northeastward to the northern limits of the basin.

*Working the "Big Vein" coal bed.*—The room and pillar system in some of its various modifications is the method of mining commonly employed in working the coal of the "Big Vein" coal bed in

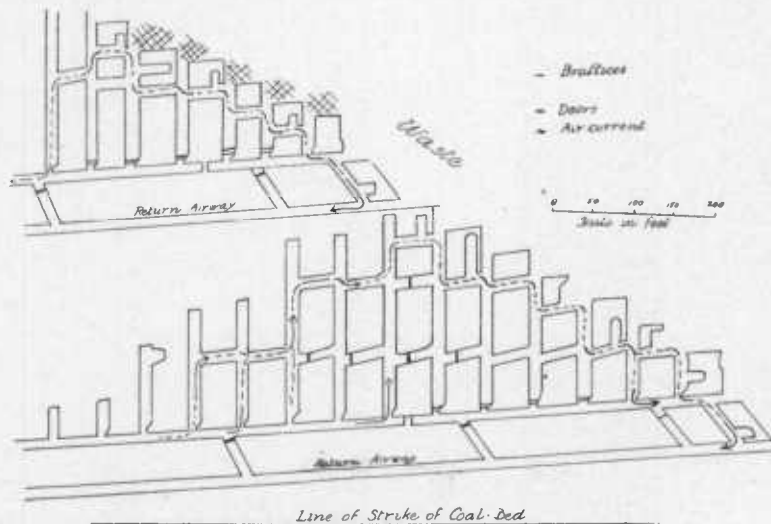

FIG. 28.—Diagram showing a Section of the Workings of the "Big Vein" for Mine No. 1, Georges Creek Coal and Iron Company.

the mines of the Georges Creek region. Two or more main headings or entries, parallel to each other, with a pillar of coal between them varying in thickness from 50 to 100 feet, are driven from the entrance of the mine into the area to be worked. One of these entries is used for haulage, one for an airway for the return ventilation, and sometimes a third and separate one is driven for a "manway" or "traveling way" for the use of the miners in going to and from the working places. Off the main entries at intervals of from 300 to 500 feet side entries are turned at angles of  $30^\circ$  to  $90^\circ$  from the course of the

main entries and are driven in pairs to the extremities of the area to be mined. One of each set of two parallel entries is used for haulage, a travelling way for miners, and for a passage way for the air going into the working places. The other is for the return air on its way to the main entry after it has ventilated the rooms and pillars. The side headings are driven on such courses that the grades of the haulage tracks will be in favor of the loaded mine cars coming out, which also insures natural drainage from the innermost workings of the mine toward the main entry and from thence to the surface through the mouth of the mine, or to the sump.

The side headings divide the coal into blocks 300 to 500 feet wide. Through these blocks rooms are driven, extending from the haulage way of one pair of headings to the return airway of the pair of headings next above them, in the direction of the "rise" of the coal bed. Side entries are driven usually 8 feet wide parallel to each other and with about 50 feet of coal between each pair. Rooms are made from 12 to 16 feet wide with a pillar of coal between them from 30 to 75 feet thick, the size of the pillars depending upon the thickness of the "cover" or rock strata lying above the coal bed.

In some of the mines of Georges Creek the rooms are driven as the headings advance. Sometimes every other room is driven as the entries advance and the intermediate rooms are not driven until just before the pillars are to be drawn. In other mines rooms are not broken off from the headings until the latter reach the limits of the area to be worked. Then a limited number of rooms are driven at the interior end of the headings, and as soon as the rooms are through the block of coal above the headings the pillars are drawn. The method of drawing rooms as the headings advance furnishes the quickest output of coal in opening a mine, but does not secure as large a yield of coal to the area as when the rooms are not driven until the headings reach their limits and the rooms broken off at the end of the headings. The Consolidation Coal Company adopts the plan of turning off the side entries at an acute angle from the course

of the main entries, in order to reach their boundaries by the shortest course.

*Roof coal, props, etc.*—Immediately overlying the “Big Vein” is a brittle slate interstratified with thin seams of coal known as the “Wild Coal” or “Rashings.” Upon exposure to the air the wild coal crumbles and falls. To prevent it from falling some of the coal of the upper portion of the seam known as the roof coal is commonly left. The roof coal contains many “slips” or inverted wedge-shaped masses, formed by the cleavage planes of the coal bed. To prevent these from falling it is necessary to use props in all of the wider working places of the mines. Props are placed near the center of the rooms and about 4 feet apart. The props are cut, by the miners who set them, slightly shorter than the height of the coal, and a wedge of wood called a “cap-piece” is driven between the prop and the roof. Frequently the prop supports a “cross-bar” placed at right angles to the course of the room and the prop and cross-bar are wedged securely between the floor and roof by a cap-piece. Generally the cross-bars are let into the coal of the “rib,” or side of the room. Sometimes two props are placed under each cross-bar, one near each end of the bar. The cross-bar and the prop or props supporting it are called a “set of timbers.” To lessen the danger from “slips,” rooms are driven, where it is possible, in a direction oblique to the course of the cleavage planes of the “slips.” The course of these slips in the central portion of the region is S. 28° E. By taking this precaution the “rib” or unmined coal of the pillar is made to assist in keeping the slips from falling. More serious and fatal accidents occur from the unexpected fall of these slips than from any other cause. The timbering is kept close to the face of the rooms, and not more than 5 or 6 feet of unsupported roof is allowed between the timbers and the face of rooms. The course or direction of entries and rooms is directed by “points,” which consist of two strings suspended from nails driven into the roof of the mine. The “point nails” and strings are set by a transit or compass. The line joining the point strings is the course or direction on which the entry or room is to be

driven. Each time the miner cuts his place he is required to sight over the "point strings" to a light held at the "face" of the place he is driving, and to cut a "rib" or side of the place so that it is from one to two feet from and parallel with the line of points. Occasionally the heading or room is driven with the point line in the center of it, but the usual custom of the region is to "carry from one to two feet of points on the left-hand rib."

*"Break-throughs."*—The absence of fire-damp enables the miners to drive their working places long distances in the coal with safety without breaking through the pillar from one entry or room to the next for ventilation. In some mines it has been the practice to leave the pillars between the entries unbroken for distances of 400 feet or more, and the pillars between rooms have frequently remained unbroken throughout their entire length until the pillars are ready to be drawn. Of late years, however, owing to the introduction of powder for blowing down the coal and the requirements of the mining laws, "break-throughs" or cross-cuts are driven through the pillars as the working places advance at distances apart not greater than 35 yards.

The width of rooms, and the size of the pillars left between the rooms, vary according to the thickness of the "cover" or overhanging strata. Where the cover is "light," as is more likely to be the case on the edges of the basin, a pillar 20 feet wide is sufficient to ensure safety to the workings of the mine. Where the cover is heavier thicker pillars are required. In many mines care is now taken to leave a solid body of coal below each set of rooms, of sufficient size to stop or localize a "squeeze" or "crush" of the coal if it should occur. Experience has taught the operators that many rooms should not be driven in a block of coal unless the pillars are drawn as soon as the rooms are through to the heading above, and then the pillars should be brought back as quickly as possible. The neglect of these precautions has caused the loss of large areas of "Big Vein" coal.

*Lifting bottoms.*—Until about fifteen years ago the coal in the lower bench, or what is commonly known as "the bottoms" of the



“Big Vein,” was not considered marketable coal on account of the slate partings it contains, and many acres of this valuable bench of coal have been buried in the waste and can never be recovered. The bottom coal in the central part of the region has always two and often three thin slates. The lowest lies about 1 foot from the pavement and varies in thickness from  $\frac{1}{2}$  inch to the thickness of a sheet of paper. The other two slates, neither of them over an inch thick, are found about 6 inches apart and from 2 to 3 feet from the floor of the coal bed. With the full height of the “Big Vein” of 10 or 11 feet in the central part of the basin, the heaving of the pavement and settling of the roof when the pillars are being drawn frequently reduce the height of the haulage road so much that it is often difficult for a mine car to pass under the cross-bars and into the pillar before all of the coal is removed. The timbers first set are bent and broken so that it becomes necessary to place new sets of timbers with shorter props between the original sets.

When the breast coal only is mined and the height of the place is, therefore, from two and one-half to three and one-half feet less than where the bottoms are lifted it is still more difficult to retain head-room for cars to pass to and from the pillars. This consideration, as well as the three feet or more of coal gained in working the bottom coal, is found to overbalance the extra labor and care required in separating the slates in the bottom bench. By careful mining this bottom coal becomes quite as marketable as the breast coal and few operators now adhere to the old custom of mining only the breast coal.

*Drawing pillars.*—When a number of rooms at the interior end of a heading are finished the pillars of coal between them are taken out, and to secure the greatest yield of coal from the pillars the “pillar drawing” is done as quickly as possible. Pillaring is begun near the end of the last interior room of a heading by driving a cross-cut into the pillar which lies between that room and the boundary or “waste,” as the case may be. Through this cut the stump of coal between it and the waste is removed. When the latter stump is finished, an-

other cut is made into the same pillar about 30 feet farther down the room than the first cut. At the same time that the second cut in the room next to the boundary is being driven a cut is started near the end of the second room from the boundary and is driven through the pillar between the two last rooms. When all the coal that can be gotten is taken out of the stumps that lie above the two last-named cuts, new cuts are started in each of the two last rooms about 30 feet below each former cut, and simultaneously the first cut is started near the end of the third room from the boundary, and so on. As soon as the coal above the first cut in each room is mined, the first cut in the room next outside of it is driven towards the boundary, and pillaring in that room is begun. As soon as each cut is finished and the coal above it taken out, a new cut is started lower down the room until the pillars are brought back to the haulage heading, then the stump between the haulage heading and the return air heading is gradually brought back toward the main entries by cross-cutting it in the same manner as the pillars between the rooms. In some cases the pillars on both sides of a room are taken out from the one room and several modifications of the general plan of robbing pillars just described is resorted to where conditions require it.

While the pillars between rooms are being drawn new rooms are driven into the block of coal between the old rooms already up that are being pillared and the main heading, unless rooms have been previously driven while the headings advanced. These new rooms take the place of those that are finished, and so the output of the mine is kept up to a regular capacity.

In drawing pillars care is used to take out all the coal possible. Not only on account of the commercial value but also to induce the strata above the "waste," or coal taken out, to break through to the surface. For when the rocks lying above the waste are properly broken their weight falls upon the waste and the pressure upon the coal in the pillars is relieved. If the coal in the pillars is not thoroughly taken out what is left prevents the strata above the waste from falling and breaking, the pressure rides over onto the pillars

and, if other conditions are favorable, produces a "squeeze" or "crush," until finally no amount of propping will prevent the rooms from falling in. Often when a mine is idle for any length of time from any cause, unless the mine is frequently examined and timbers set where needed, the roof falls in, in places. If the fall occurs in a heading the debris is taken outside of the mine or else thrown into cross-cuts no longer needed for ventilation, et cetera, but when the fall occurs in a room it is often found more economical not to remove the debris but to drive a new room through the center of the pillar, and the coal on both sides of the new room being thrown from the top downwards. In driving the pillars between rooms where the cover is heavy, it is, therefore, advisable to leave the pillars between them large enough to allow a new room to be driven in them if it should be necessary.

Props are used plentifully through the region at most of the mines. They are generally required to be 4 inches between the bark at the small end, if of hard wood, and 5 inches if of soft wood. Their use is principally for the purpose of keeping the "slips" and loose places of the roof from falling, and they are not expected to support the weight of overlying strata. When the weight of the rocks above the coal bed comes upon them they are soon broken. It is the custom to try to prevent "squeezes" or "crushes" of the rooms and pillars rather than to control them after they have started. Sometimes, however, when a "squeeze" does occur "shanties" are built to stop it. These "shanties" are wooden structures resembling the walls of an old-time log cabin. They are wedged tightly between the pavement and the roof of the mine. The means of prevention of "squeezes" generally used are proper robbing of the pillars to cause the strata to break; the avoidance of having too many rooms at one time in one block of coal; the leaving of a large enough pillar between the rooms, and of a still larger pillar or block of coal between blocks of coal being worked. Keeping the pillars in line as they are drawn back is found to assist greatly in securing the coal in them, since if one or two pillars are out of line with the rest, those out of

place receive an unequal and much greater share of pressure than the others. They become crushed so that they cannot be taken out, while at the same time they prevent the thorough breaking of the strata above the coal. The importance also is realized of protecting all main entries by solid pillars of coal on either side of them, which pillars are not taken out until the workings of the mine are brought back to these headings. When it is possible to do so, the headings are driven to the end of the property and the coal is taken out beginning at the property line, or extreme "inside place" as it is called, and the mine is worked back towards its mouth. Frequently  $\frac{2}{3}$  of the total amount of the coal contained in the "Big Vein" is taken out and sometimes more than 13,000 tons per acre is secured.

It has been found that the greatest production of coal per acre has been secured where not more than 12 or 14 parallel rooms in one heading are worked at one time. In one-half of these the pillars are being drawn while the others are being driven.

One of the most serious causes of loss of coal is idleness of the mines. At times the supply of ears is short or, as is not so often the case, the operator has not enough orders for coal to keep the miners working steadily or to their full capacity. Strikes of the miners sometimes enforce idleness of the mines. In all of these cases more or less loss of coal is the result. The longer the pillars stand where the pressure in them is great, the more unsafe to workers they will become. Often a pillar will be perfectly safe one day and the next it will be unfit for men to work in.

Some operators employ a "night shift," or force of men at night, for the special purpose of saving coal of "the pillars" that would be lost if it were left in only over night. Experienced miners know when a place is safe and when it is unsafe to work in, and are careful to protect themselves against accidents by proper timbering of the roof. The condition of the roof is determined by sounding it with a pick. A practiced ear can readily detect when the roof is strong and when it is likely to fall.

*Culling the coal.*—The coal of the "Big Vein" is soft, can readily

be mined by hand pick-work, and but few coal-mining machines are in use. The first coal-cutting machines introduced into the region were installed by the Consolidation Coal Company in 1899. The machines used are all of the "puncher" type and no chain machines are operated. Mining machines undercut the coal for a distance of five or six feet, and the "breast" is then wedged or bored and shot down by powder<sup>1</sup> or dynamite. A machine runner and a helper are required to operate each machine.

When machines are worked the mining machine's wheels rest upon a broad cutting board. The board is placed close against "the face"

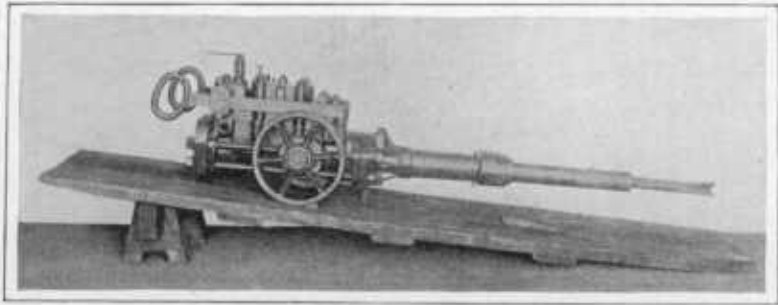

FIG. 29.—Coal-Cutting Machine, called by the miners "a Punching Machine."

and is inclined towards it, so that the weight of the machine is thrown against the face at each stroke or blow of the machine. The machine runner directs the blow to the desired point by the handles. The helper shovels back the coal from the undercut, so that a fresh face of uncut coal is continually exposed to the pick-point of the machine.

The methods of cutting, however, most generally in use throughout the mines of the region is to undercut and side-cut or shear the coal by hand, by means of a pick, and then wedge or blast down the coal. The undercut is made in a soft layer in the breast coal, called the "mining ply." This mining ply is 3 to 6 inches thick and is just

<sup>1</sup> The use of powder for blowing down the coal is now prohibited by most of the operators.

above a thin parting of slate which ordinarily occurs about three feet from the floor of the "Big Vein." The coal mined above this bench, known as the breast coal, is then loaded into the mine cars. When all the coal above the slate parting is loaded, the slate is carefully taken up and thrown into the "gob," or place for refuse, on the unused side of the room. Then the lower bench, known as the bottom, is wedged up, cleaned from slate and loaded into the mine cars. The amount of coal that a miner can cut by hand and load per day is about 5 tons. At the present rate of 60 cents per ton for room-work the miner can earn \$2.50 to \$3.00 for a full day's labor. As a rule from two to four men work together in a room, and the coal mined and loaded is divided equally between them. Boys over 14 years old are employed under the supervision of older and more experienced miners. The boys are allowed a "half-turn," that is, they are credited with one-half the labor of a man in the division of the earnings. Care is taken that the drivers distribute the cars to the miners so that each has the same number of cars to load in a day's time. In loading the cars the fine coal is first shovelled into the bed of the car and the lump is used to build up or top it from one foot to eighteen inches about the body of the car.

From the rooms each car as loaded is taken out by a driver with a horse, mule, or motor to the side heading. When the driver has gathered loaded cars from several rooms, the grade of the heading determining the number that can be successfully handled, the driver pulls them out to the main entry, or haulage heading, where they are fastened to the trip on its way to the tippie. Each loaded car bears the check of the miners who have loaded it. When the cars are weighed, just before they are dumped, the man who weighs them, takes off each check and credits the weight of the coal to the miners whose names appear on the weight sheet opposite the number of the check.

The mine cars containing the coal, after being weighed, are emptied, usually without screening, into the railroad cars. The coal from most of the mines of the Georges Creek region is sold as run

of mine. Much care is taken to secure as large a percentage of lump coal as possible. The coal produced in driving headings and rooms is, on an average, coarser and contains a greater percentage of lump coal than that obtained in drawing pillars, especially is this true where the cover is heavy, for the weight upon the pillars then crushes and breaks the coal. For the latter reason the coal produced by the mines lying on the edges of the basin, where the cover is lighter, contains a larger proportion of lump.

*Wire rope haulage.*—The motive power used on the main haulage headings is usually some application of wire rope haulage. Where the grades of the haulage entry are less than 10 per cent for long roads and 5 per cent for short ones, a tail-rope system is most frequently used. Where the grades are greater, gravity planes are found to be better suited for haulage purposes.

In a tail-rope system the ropes for pulling the empty cars into the mine, called the tail rope, is carried along the side of the track, and is guided and kept in position by iron sheaves. At the inside end of the haulage entry the tail rope passes around a large iron sheave placed horizontally, called a "bull-wheel." The tail rope then returns toward the mouth of the mine, down the center of the haulage track. The end of the tail rope is fastened to the front end of the train or "trip" of empty cars going and by it the "trip" is pulled into the mine. Another rope is attached to the rear end of the "trip," and as the tail rope pulls the "trip" in, the pulling rope is unwound from its drum and taken in with it. When the empty cars have been distributed into the various side headings, the pulling rope is fastened to the front end of a train of loaded cars ready to come out. Each rope is wound on a separate drum, working independently of each other. Each drum has a clutch, so that the engineer can cause it either to revolve on its shaft or to turn with its shaft as required. One engine operates both drums. When the tail-rope drum pulls the rope and with it the train of cars into the mine, the other rope is wound off of its drum. When the pulling rope pulls the loaded cars out of the mine the tail rope is unwound from its

drum. The length of the pulling rope is equal to the length of the haulage road, while the length of the tail rope must be double that of the other.

In the smaller mines where the grades are less than 5 per cent and where the length of the haulage entries is not more than 2000 feet, horse power is generally preferred. Where gravity planes are used, the loaded and empty cars are connected by a wire rope which passes around a drum or set of wheels at the top of the plane. The loaded cars descending lift the empty ones from the foot to the head of the plane. Two or more loaded cars are commonly let down the planes at a time, and the same number of empty cars lifted by them. The speed of the cars is regulated by brake bands acting on the wheels at the head of the plane. These brakes are controlled by a lever operated by the man who "runs the plane."

*Another method of underground haulage.*—At the power plant of the Consolidation Coal Company's Pumping Shaft, near Borden Shaft, a high-pressure Norwalk Compressor or locomotive charger supplies air for a compressed-air locomotive. The air from this compressor, at a pressure of 800 pounds to the square inch, is carried 6000 feet underground and charges a locomotive used for haulage in the Hoffman mine. A high pressure air compressor at Ocean No. 1 also furnishes air at a pressure of 800 pounds to the square inch to a motor in Ocean No. 8, the pipes for charging the latter passing through the entries of Ocean No. 1.

For gathering loaded mine cars in rooms and side entries and delivering them on rope roads, horses or mules are, as a rule, employed. Mules are preferred to horses by the Consolidation Coal Company, while the Georges Creek Coal and Iron Company and other large operators give horses the preference. Mules are less liable to diseases of the hoofs and feet, particularly navicular disease, than horses. On the other hand, the pulling power of a horse is considered to be considerably greater than that of a mule.

The Consolidation Coal Company uses eleven small compressed-air motors for gathering mine cars in the rooms of the Hoffman mine.



A test of the comparative cost of gathering cars by motors and mules in the mine has proved the superiority of the former. An account of the result of this test has been read by Mr. B. S. Randolph, formerly mining superintendent of the Consolidation Coal Company, before the American Institute of Mining Engineers.

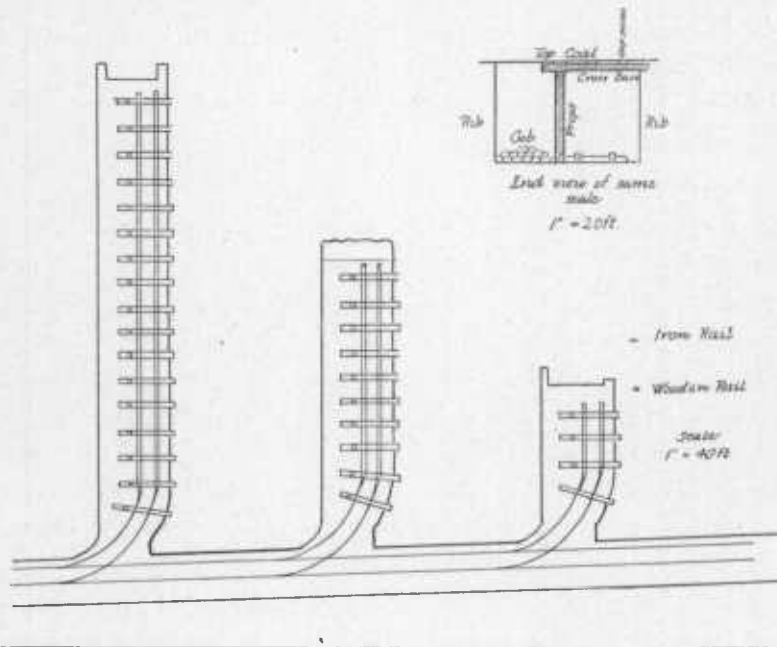

FIG. 30.—Sketch illustrating the usual arrangement of Tracks, Props, and Cross-bars in Rooms.

Where a mine is entered by means of a slope, such as the Eckhart and Hoffman mines of the Consolidation Coal Company, a drum on the surface wound by a stationary engine pulls the loaded ears up the plane by means of a wire rope. The empty ears going down the plane by gravity pull the rope in with them. A tail-rope system, however, brings the coal to the surface on the slope of Ocean No. 1.

*Mine tracks.*—The gauge of tracks used in the different mines of the region varies from 30 to 48 inches. In headings T-iron weighing

from 16 to 40 pounds per yard is laid upon hewed or sawed cross-ties, the latter placed 18 inches to 2 feet apart. Where the haulage is done by ropes, sheaves, or rollers to guide and reduce the friction of the ropes are fastened to two cross-ties. On straight roads these rollers are of wood, revolving on an iron or wooden spindle.

The roller is kept in position by two wooden supports, each of which has a horizontal hole of slightly longer diameter than the axle of the roller which revolves on it. The roller supports are nailed across two adjoining cross-ties in the middle of the mine car track. On curves the ropes are kept in position by iron sheaves revolving on a vertical axle.

At convenient points in the mine, usually close to where the side headings join the main entries, turnouts, or side tracks are made for the empty cars to pass the loaded ones. On main headings switches or turnouts are constructed of T-iron. In rooms the tracks are generally of wood, the rails, of sawed lumber 4 by 4 inches square, are laid upon angle ties which have notches slightly more than 4 inches wide, cut into one edge of them to receive the rails. The rails are laid on these notches and are held securely to the gauge of the track by a wedge driven on the outside of the rails. The angle ties are laid on the pavement, resting on the base of the triangle opposite the notch which holds the rail. Sometimes strap-iron is nailed upon the wooden rails to prevent wear and lessen friction. The tracks are carried into the rooms as the rooms advance, so that the mine cars can always stand upon the track near enough the face where the coal is mined for the miner to shovel the coal easily into them. The wooden track of the rooms is turned into the cross-cuts when the pillars are being drawn. The wooden rails are curved by sawing them partly through one side at frequent intervals on the portion of the rail to be curved. They can then be bent and fastened in position on the ties. A curved strap-iron facing is finally laid and spiked upon the "turn." In 1898 the Consolidation Coal Company alone had 75 miles of track in operation in its various mines.

*Ventilation.*—At many places through the Georges Creek valley

we can see old brick furnace stacks, which were once used for ventilating the mines. Now they are mainly monuments to the obsolete system of ventilation which has given place to more effective methods. Though wooden stacks are still used at some of the smaller mines, most of the larger mines are now provided with fans or centrifugal ventilators, the largest being 25 feet in diameter and capable of supplying 200,000 cubic feet of air a minute, with a velocity at the inlet of 25 feet per second, 2 feet 5 inches of water gauge, and 75 revolutions per minute. The fans are used in most cases as depressive ventilators, that is, the air is exhausted by them. A partial vacuum is thus created in the mine and fresh air flows in through the intake air-ways. Many of the mines, however, particularly those situated on the borders of the basin, have only natural ventilation. The dip of inclination of the coal bed increases rapidly from the axis toward the edges of the basin, and the difference of level of the upper and lower outcrops of the coal is there great enough to produce a very effective natural draught.

The temperature of the air in the working places of a mine is usually about 60° Fahrenheit, both summer and winter. With natural ventilation when the temperature outside is 60° there is little or no current passing into the mine. In summer, when the temperature of the air outside is higher than that within the mine, the direction of the air current is downward, because the cooler air within the mine being heavier than that outside the former falls and the warmer air from without rushes in from above to take its place, in its turn to be cooled down to the temperature of the mine, and in its turn to flow downward and out of the mine. In winter time the conditions are reversed, the air within the mine, being then warmer, is lighter and rises, the colder air from outside takes its place through the lower openings of the mine, and the current therefore flows upwards. Only at the times when the temperature of the air in the mine and its temperature outside are the same does the ventilation of mines naturally ventilated become impaired. These conditions of equal temperature seldom occur and do not last long enough at a time to ser-

iously inconvenience the working of the mines. Spring and fall and just after sunrise and sunset are the seasons of the year and hours of the day when natural ventilation is the least effective.

In nearly all of the larger mines of the region, whether ventilated by fans or by natural means, the air currents are distributed into the working places where they are needed, and the amount given each heading and series of rooms and pillars is controlled by overcasts, doors, brattices, and regulators. A separate current or "split" of air is given, where it is possible, to each side heading and its block of rooms and pillars. After airing one section of the mine each current is then led back to the fan opening of the mine through the return

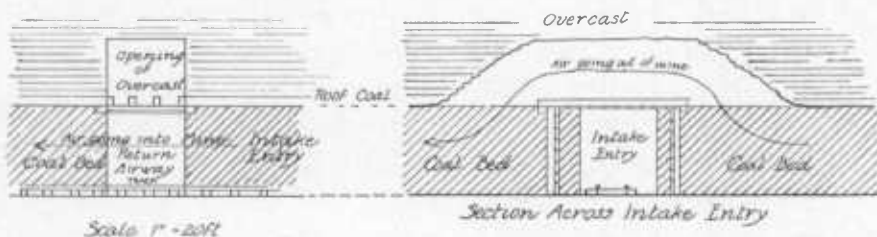

FIG. 31.—Sketch showing Relations of Overcast and Intake Airways.

air-ways. By this arrangement of currents the air containing the gases generated in each set of workings, as well as the air vitiated by men, horses, and powder smoke, is drawn directly out, without passing through other parts of the mine in which men are working.

In the Georges Creek region, owing to the absence of fire-damp, the appliances for controlling the ventilation are usually built of wood. Overcasts are used where an air-way crosses another air-way nearly at right angles. They are made by cutting out the roof of the return air-course and carrying the air-current over the intake air-way. This is accomplished by building an artificial plank roof over the intake and stopping a connection between the two on the sides by wooden brattices or doors. The size of the overcast, the height and the area of its opening, depends upon the extent of workings to

be ventilated through it. Brattices and doors of wood are used to prevent the ingoing air from taking a short cut to the return air-ways. Doors are used instead of brattices where cars or men must pass through them. By means of doors and brattices the air-currents or forces are directed into the interior of the mine. Doors are constructed to close in the direction in which the air-current travels, and are hung with lower hinge driven farther into the post that supports them than the upper one, so that they close automatically. Sometimes cloth, specially made for the purpose, is used for brattices, but brattice cloth is ordinarily used only for temporary purposes.

Regulators are constructed by cutting an opening in a door or brattice and fitting it with a slide, which being more or less opened or closed controls the amount of air that passes through and gives to each heading or section of the mine the amount of air required for it. In some mines canvas curtains are hung in the air-courses to divert the air-currents and act as regulators. Wooden stacks are often resorted to, temporarily, in opening a mine, or are used to ventilate outcrop workings of limited extent.

*Gases.*—The “Big Vein” is commonly said to contain no fire-damp, and the experience of the mining companies generally bears out this statement. This claim is not strictly true. The amount of fire-damp given off by the “Big Vein,” however, is so small that only once in fourteen years has enough of it accumulated in one of the largest mines of the region to be detected. This accumulation was found in some old workings which had been bratticed off from the rest of the mine, where the air-current could not reach and dislodge it. The amount of fire-damp found on this occasion and under these conditions was just sufficient to light and burn and was not enough to cause an explosion of any consequence. In the smaller coal beds, however, notably in the one lying 225 feet above the “Big Vein” (Waynesburg) at Lonaconing, a considerable amount has been found.

Although the mines in the “Big Vein” are practically free from fire-damp, large quantities of  $\text{CO}_2$ , or black-damp, are often met

with in all of the mines of the region, particularly in those which have the most "waste" or worked-out territory, adjoining them. From the surrounding waste, especially at times of a change from a high to a low barometer, the black-damp pours into the mine and causes much inconvenience and sometimes a stoppage of work if the mine is not provided with adequate ventilation to carry off the gas.

*Light.*—The miners work by the light of a tin lamp carried in their caps. Safety lamps are not used at all in the "Big Vein" of

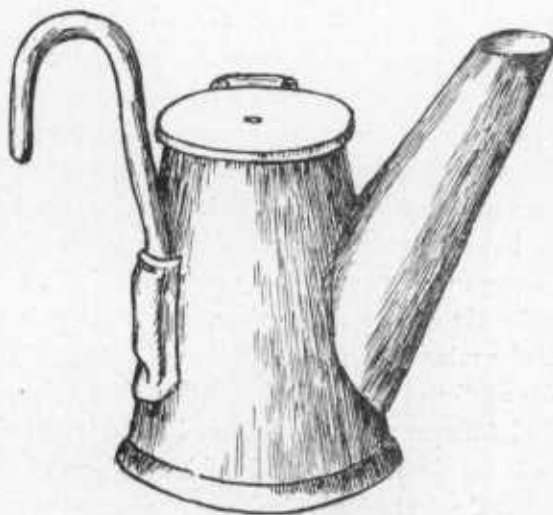

FIG. 32.—Sketch of Miner's Lamp used in Georges Creek Basin.

the Georges Creek region. A number of the mines have electric light plants for lighting the boiler and engine rooms and underground pump rooms, but electricity is not used for lighting the working places of the miners.

*Drainage.*—As the "Big Vein" throughout the southern section of the region lies above the water-level of Georges Creek, the drainage of the mines from the middle to the southern end of the basin is natural and inexpensive. South of Ocean all of the mines are worked by drifts, their openings being located as near as possible to

the lowest point of the outcrop of the coal bed in each property operated, and the entries driven to the rise of the seam. A group of mines lying in the center of the basin at the middle of the region is drained by a tunnel which empties into Georges Creek at Midland. This drainage tunnel was driven by the Consolidation Coal Company through the strata underlying the "Big Vein," tapping that coal bed in the lowest workings of Ocean mine No. 1. The tunnel drains a large area of the workings of Ocean mines No. 1, No. 7, and No. 8 of the Consolidation Coal Company, as well as parts of mines No. 1 and No. 4 of the Georges Creek Coal and Iron Company. Two Worthington duplex pumps, with capacities of 550 gallons per minute each, one Worthington pump with a capacity of 200 gallons per minute, one Cameron pump with a capacity of 700 gallons per minute, and a Merrill displacement pump with a capacity of 100 gallons per minute, are also required to drain Ocean mine No. 1 of the Consolidation Coal Company. All pumps in the mines of the Consolidation Coal Company are operated by compressed air. The engines compressing the air are on the surface, and the air is conveyed to the pumps in the mine by pipes.

Three miles northeast of the drainage tunnel at Midland the Consolidation Coal Company has a shaft and pumping station for the purpose of draining the Hoffman and Eckhart mines, or Ocean No. 3, and No. 3½. At the foot of this shaft are two large pumps capable of lifting 4000 gallons of water per minute to the surface, and three other smaller pumps for delivering water into the main sump of the mine from which the two larger pumps raise it to the surface. The Hoffman mine has also eight pumps with capacities of 100 gallons per minute each, situated nearer the slope mouth. The mines north of Frostburg are naturally drained.

The Consolidation Coal Company is now driving a drainage tunnel through the strata underlying the "Big Vein" from a point near Clarysville. This tunnel will tap the "Big Vein" at the lowest point of the workings of the Hoffman mine and will drain the water from all of that company's mines in the northern end of the basin

into Braddock Run. The tunnel when completed will relieve the company of the necessity of operating the pumping shaft.

For draining local depressions or swamps which are frequently found in the mines of the region, syphons are sometimes used, especially when only temporarily needed, but ordinarily wherever the mine entrance is higher than any part of the interior of a mine which has no other outlet for water, a pump is used. When a pump is needed to drain a mine a "sump" is made by excavating the strata beneath the coal bed at the lowest part of the mine, so that all the water of the mine drains into it. The sump is usually made large enough to act as a storage place for water in case of the stoppage of the pump. The pump is placed as close to the sump as possible and is operated by compressed air or steam conveyed to it by pipes from a boiler, in most cases located on the surface.

*Method of conveying the coal from the mines to the tipples.*—The outcrop of the coal at many of the openings of the mines in the southwestern end of the basin is so high above the Cumberland and Pennsylvania Railroad that long and steep gravity planes have been built to deliver the coal from the mouth of the mines to the tipples at the railroad. The outside gravity planes are operated on the same principle as those used and described in the inside workings of the mines. Various patterns of wheels for operating these gravity planes are found in the region, the older styles being of very large diameter and greater power, the newer ones of smaller diameter and consequently more portable and convenient to erect, but the latter have the serious disadvantage of wearing out the ropes sooner. A tramway two miles long connects the openings of the Jackson mines of the American Coal Company with their tipple on the Georges Creek and Cumberland Railroad siding at Lonaconing. The mine cars are hauled from the mines to the tipple over this tramway by two narrow-gauge locomotives. At the Appleton mine of the Maryland Coal Company a small locomotive also hauls the coal nearly half a mile over a tramway from the mine to the tipple on the Georges Creek and Cumberland Railroad.



At mines No. 1 and No. 4 of the Georges Creek Coal and Iron Company near Lonaconing, where a double tail-rope system is used, the loaded cars are run by gravity from the drift-mouths of these "Big Vein" mines to the tipples on the Cumberland and Pennsylvania Railroad. The tail rope is not disconnected from the trip until the train reaches the landing at the tipples. The tail rope is thus brought into a position where it can be conveniently fastened to a train of empty cars and pulls them into either mine. The coal from No. 1 mine, if so desired, can also be taken by the same tail-rope system to the tipples on the Georges Creek and Cumberland Railroad. At the Sewickly seam mines of the Georges Creek Coal and Iron Company, near Lonaconing, a retarding conveyor is used to deliver the coal from the mines to the tipples and washer. The coal is brought to the head of the conveyor by a four-ton electric motor. Between Lonaconing and Midland, mines No. 3 and 9 of the Georges Creek Coal and Iron Company are connected with their tipples by gravity planes, having steep grades. Northeast of Midland, where the "Big Vein" passes under the bed of Georges Creek, the tipples are almost invariably close to the coal openings.

*Signals.*—When wire-rope haulage is used signals are employed to notify the engineer in the power house on the surface when to pull and when to stop the trip. For this purpose two parallel wires about six inches apart are attached to insulated supports on the "rib" of the haulage entries. These wires are connected with an electric battery which operates an electric gong in the engine house. The brakeman who accompanies the trip carries a small thin bar of wire with which he makes a connection between the two wires, establishing the circuit by which the bell in the engine house is rung one, two, or three times, according as it is required to stop, or pull the trip out or in. On gravity planes both in the mines and on the surface it is necessary for the man at the foot of the plane, who connects and disconnects the rope, to signal the man at the top, who controls the brakes and "runs the trip," when to let down the cars. At the Sewickley seam mines of the Georges Creek Coal and Iron Company

near Lonaconing, a retarding conveyor is used to deliver the coal from the mines to the tippie and washer. The coal is brought to the head of the conveyor by a four-ton electric motor. For this purpose a gong operated by electric wires is sometimes used but more frequently a wire pulled by a lever lifts a hammer which falls upon a piece of sheet iron at the other end of the plane. Sometimes a signal arm or board operated by a lever and wire is used.

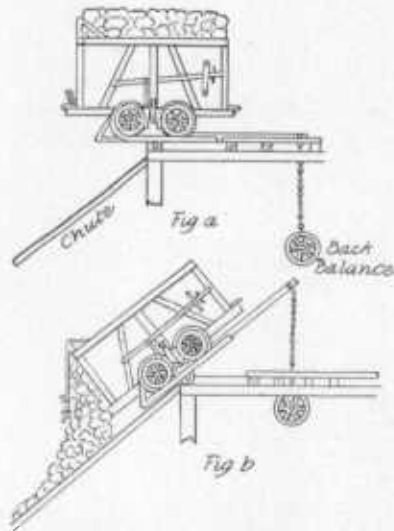

FIG. 33.—Sketch showing form of Tippie commonly employed in Georges Creek Region.

*Tippies.*—Tippies of various kinds are used for dumping the coal from the loaded mine cars into the railroad cars. Those of the simplest construction being the cheapest and least liable to get out of order are generally preferred. Since the advent of the high 100,000-pounds capacity steel railroad cars, tippies are built so that the mine car tracks on the tippie have an elevation of about 22 feet above the railroad track. Before the high steel cars were used tippies were built considerably lower. The coal first falls into a sheet-iron chute and slides down the chute into the cars. The elaborate tippies found

in the anthracite and bituminous coal fields are rarely seen among the mines of Georges Creek. Tipples are provided with steps for the men employed in weighing and dumping the coal to ascend and descend to their work. As a rule, the scales for weighing the mine cars are located on the tipple structure from 20 to 25 feet in front of the tipple proper, and a small building encloses the weighing beams and affords the man who weighs the coal a place to keep his sheets upon which the record of the weight of loaded mine cars is kept. In some cases the mine cars are weighed at the top of gravity planes, as at mine No. 3 of the Georges Creek Coal and Iron Company, in which case there is no scale or weigh house on the tipple structure.

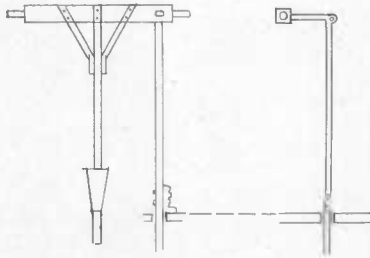

FIG. 34.—Automatic Pin-puller used by Maryland Coal Companies.

Where tipples are at the foot of gravity planes, where it is possible to do so, the tipple structure is built out of line with the plane so that cars breaking away on the plane will jump the track at the foot of the plane and will not wreck the tipple. To prevent runaway cars from injuring the tipple, safety latches or switches are used on most planes, and are operated by wires which are worked by levers from the top or bottom of the planes.

Automatic pin-pulling devices for the purpose of saving labor in dumping the cars are used at most of the tipples through this region. These appliances are of several different patterns and some are quite ingenious. A further saving of labor in dumping the coal is effected by giving the track returning from the tipple a down grade to allow

the emptied ears to run out of the tippie automatically. At some mines, where the conditions require it, more complicated tippies are used, notably at mine No. 1 of the Georges Creek Coal and Iron Company, at Lonaconing. At this mine the level of the coal at the mouth of the mine is not high enough above the Cumberland and Pennsylvania Railroad siding to use a gravity plane advantageously, while it is too high for an ordinary chute tippie. To avoid breakage

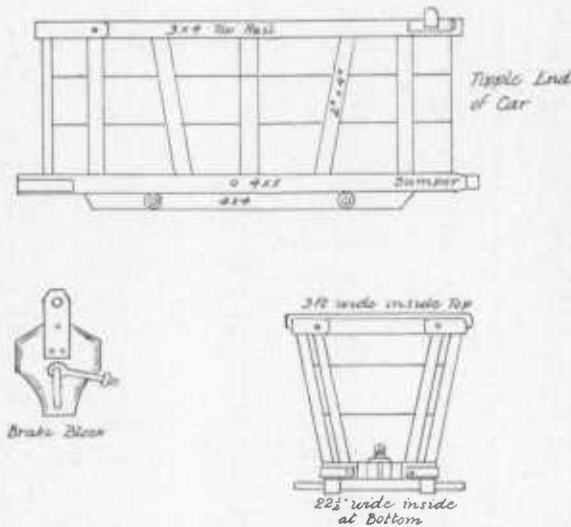

FIG. 35.—Sketch of Body of Mine Cars used by Consolidation Coal Company.

of coal a Mitchell cross-over tippie with a basket attachment is used. At this tippie the coal is first dumped into the basket, then the basket containing the coal is lowered and emptied into the railroad ears on the siding of the Cumberland and Pennsylvania Railroad. Usually the chute stands sideways to the railroad siding. At the Jackson mines of the American Coal Company a Mitchell tippie is in operation and the coal is dumped endwise into the railroad cars. Railroad sidings are constructed with light grades passing the tippies, so that the empty and loaded ears will run easily and at the same time

be controlled while running towards and away from the tippie. From  $1\frac{1}{4}$  to 2 per cent grades are given the sidings. The railroad cars are controlled by their brakes and by blocks of wood with wooden handles which the car runner wedges between the rail and the wheel. At a weigh office, sometimes called a manifest office, a short distance below the tippie, each railroad car is weighed after it is loaded.

*Mine cars.*—Mine cars are made to hold from 2 to  $2\frac{1}{2}$  tons of coal. They are framed of oak, the bottoms are usually made of  $1\frac{1}{2}$ -inch oak plank and the sides of 1-inch oak boards.

The cars are generally constructed so that they are wider at the top than at the bottom, the sides having a flare or batter, so that the top of the car projects as far as the outside of the wheels. The above cut represents the car commonly seen in the region.

Each car is provided with an end gate which is hinged at the top and is kept closed by an iron pin fitting into a hole in the iron draw-bar of the car. This pin must be pulled before the car is dumped. The car is so placed to be loaded in the rooms that the ends opposite the end gate is nearest to the "face" of the coal, by so placing the car the end with the gate always comes out of the mine facing the tippie. Each car is also furnished with a brake to control it on grades. The brake commonly used is the old-fashioned single one, consisting of a 3 by 12-inch block between the wheels operated by a lever at the side of the car. This brake has not sufficient power to control the cars on heavy grades and formerly the brakemen had to insert a piece of wood, called a "sprag," between the spokes of the wheels. The sprag caught against the bottom of the car as the wheel revolved and stopped it. The loss of many fingers and thumbs resulted from the use of sprags. Now the double brake designed first by John T. Pierce in 1868, and since much improved upon, is used where grades are heavy. An iron bar passes under the car and operates, as shown in the cut, a pair of wooden blocks between the wheels on each side of the car. The brake lever or handle is generally placed on the left hand facing the end gate of the car, so that the driver can handle the brake with his right hand. Wooden han-

dles are preferred by most operators, as they have more elasticity than iron.

The wheels revolve on their axles instead of with their axles, as the wheels of railroad cars do. Mines having steep gravity planes have a front board built above the gate ends to keep the coal in place when the cars are run down the planes.

#### IRREGULARITIES OF THE "BIG VEIN."

The thickness of the "Big Vein," as well as that of the smaller seams of coal is variable. In the same mine the coal bed is frequently found both considerably thicker and thinner than its normal size. It is a general rule that whenever the seam has an unusual thickness or thinness that there is an area nearby of thinner or thicker coal respectively, and the average height of the thickest and thinnest part of the seam is nearly the normal size of the coal bed.

Some inconvenience in mining is caused by the sudden changes in the pitch of the seam which sometimes upset prearranged plans for haulage and drainage.

Such a change of pitch occurs in mine No. 3 of the Georges Creek Coal and Iron Company near Lonaconing. In the trough of the basin rolls of the coal bed causing uneven grades are also found.

In the works of the Eckhart mine, or Ocean No. 3½, is a small knoll which dips in all directions.

The area of the Georges Creek Coal basin is parallel to the general trend of the strata of the Appalachian region, and has a course of about N. 35° E. The axis also generally inclines gently towards the northeast. The effect of the inclination of the axis is to produce a slightly different line of strike or water-level line of the coal beds on either side of the basin. These lines of strike generally diverge slightly from each other towards the northeast but are not uniform over any large extent of territory, and the differences are usually too slight to be noticeable. The northern inclination of the axis of the basin produces a fall of forty feet from the lowest point of the "Big Vein" at Midland to its lowest point near the foot of the Consolida-

tion Coal Company's pumping shaft, a distance of three miles. Between these two points, however, there is an antilinal ridge which crosses the axis of the basin and prevents the pumping shaft from draining the workings of Ocean No. 1. Faults, clay veins, and "horse-backs" are rarely found in the "Big Vein" mines of the Georges Creek region.

*Cleavage planes.*—The planes of cleavage of the bituminous coal beds known as the "butts" and "faces" are either not found at all or only imperfectly developed in the "Big Vein" of Georges Creek. The Upper Sewickley coal bed lying about 110 feet above the "Big Vein" in the central part of the region, however, has this cleavage well developed, and owing to its resemblance in that respect to the bituminous coals it received the name of the "Gas Coal Vein" in the early years of coal mining in the Georges Creek valley. This cleavage, which produces the cubical fracture of the gas coals, however, is the only point of resemblance that the Upper Sewickley coal bed bears to the bituminous gas-coal seams. Some portions of some of the coal beds have the cleavage while in other benches of the same seams it does not appear. The lower bench of the "Dirty Nine-foot Vein," or Franklin seam, in the Union Mining Company's mine near Barton, has no noticeable cubical fracture, in that respect resembling the "Big Vein." Near the top of the seam, however, a thin layer of coal is found, which has the cubical fracture well developed, thus strongly resembling the coal of the Upper Sewickley or Tyson seam.

#### SMALL VEINS.

Only within the last three or four years has the development of the smaller coal seams of the region received much attention, for only within the last few years have the conditions of labor and the state of the coal market allowed the operator to mine them at a profit. Probably no greater drawback to their earlier development has existed than the inability of the operator to find men to work them at a price per ton that would offset the freight differential that the railroad com-

panies have arbitrarily placed upon them for shipment to the seaboard. The coal of some of the smaller seams is usually of excellent quality and if properly operated is but slightly if at all inferior to the coal of the "Big Vein." All through the region from one end to the other the small seams are now being worked. The Consolidation Coal Company now has three mines in the Tyson or Upper Sewickley seam from which fuel is supplied to the engines of the Cumberland and Pennsylvania Railroad or to the boilers of their "Big Vein" plants. The Georges Creek Coal and Iron Company has just completed a washing plant to wash the slæk from its small vein mines by which a smithing coal of excellent quality is obtained, while the Union, American, New Central, and Cumberland Basin mines, operated at the southern end of the basin, are mining them extensively.

The coal beds other than the "Big Vein" worked are the "Six-foot" or Lower Kittanning, the Upper Freeport, the "Four-foot" or Bakerstown, the Franklin or "Dirty Nine-foot," and the Tyson, corresponding to the Upper Sewickley coal bed of Pennsylvania. Besides these the Brookville or Bluebaugh and Clarion or Parker seams lying below the "Six-foot" vein are mined at Barrellville, while the Waynesburg, 100 feet above the Tyson, is operated by the American Coal Company just south of Lonaconing. As far as the experience of operators in the region has gone, the "Six-foot" and Tyson seams are found to be subject to more or less irregularity of thickness and some "horse-backs." The Tyson coal bed is a split seam, the two benches of which are separated in the middle of the region, by about 18 feet of rock, mainly limestone.

Miners are paid by the ton of 2240 pounds. The present rates of the region are 60 cents for digging and loading the coal in rooms and 70 cents for heading drivers. All other labor connected with the mining of the coal is paid by the day. Miners are paid twice a month. The operators have no company stores in the State of Maryland and the men buy provisions where they please. Many of the larger companies own houses which they rent to their employees.



The miner's picks are usually sharpened and his tools kept in order by the blacksmith employed by the operator. One cent a ton is usually deducted from their earnings to cover this expense. The companies usually have an arrangement with their men by which one dollar a month is deducted from the wages of each miner to pay for medical attendance.

#### COAL OPERATIONS.

The following operators are engaged in mining the coals of Maryland for the general market:

Consolidation Coal Company.  
Union Mining Company.  
Georges Creek Coal and Iron Company.  
Maryland Coal Company.  
American Coal Company.  
New Central Coal Company.  
Cumberland Basin Coal Company.  
Georges Creek and Bald Knob Coal Company.  
Braddock Coal Company.  
Frostburg Coal Mining Company.  
Chapman Coal Mining Company.  
Piedmont and Georges Creek Coal Company.  
Midland Mining Company.  
Phoenix and Georges Creek Mining Company.  
Piedmont-Cumberland Coal Company.  
Moseow-Georges Creek Mining Company.  
Cumberland-Georges Creek Coal Company.  
Piedmont Mining Company.  
Lonaconing Coal Company.  
Coromandel Coal Company.  
G. C. Pattison.  
Monroe Coal Mining Company.  
Upper Potomac Mining Company.

Datesman Coal Company.  
Stoyer Run Coal Company.  
Blaine Mining Company.  
Garrett County Coal and Mining Company.  
Davis Coal and Coke Company.

THE CONSOLIDATION COAL COMPANY.

The Consolidation Coal Company operates the following mines in the Georges Creek region: Ocean No. 1 at Ocean, Ocean No. 2 at Frostburg, Ocean No. 3 at Hoffman, Ocean No. 3½ at Eckhart, Ocean No. 7 at Lord, Ocean No. 8 at Midland, Frost mine just north of Frostburg, two mines in the Upper Sewickley seam near Frostburg, and a mine in the Upper Sewickley at Lord or Ocean No. 7. These mines extend from the northern end of the town of Frostburg to Midland, and occupy the greater part of the northern half of the Georges Creek coal basin.

*Ocean No. 1.*—The plant and opening of Ocean mine No. 1 of the Consolidation Coal Company at Ocean Station on the Cumberland and Pennsylvania Railroad, lie a mile to the east of the center of the coal basin. The mine is entered by a slope and the coal from a large area of "Big Vein" lying in the center of the basin is brought to the surface through this opening. The average thickness of coal of this mine is about nine feet. The workings extend to the northeast nearly to the workings of the old Borden shaft. They join Ocean No. 7 to the west, the Georges Creek Coal and Iron Company's mines No. 1 and No. 4 on the south, and Ocean No. 8 on the southeast and east.

About 600 men were employed and 35 mules used in the underground operations of this mine in 1902, the maximum daily output of the mine for that year being about 2000 tons. The loaded mine cars in "trips" of 27 cars are hauled up a single-track incline to the surface and landed close to the tipple by an 18 x 36-inch double cylinder geared engine which operates two drums 3 x 8 feet. One

of these drums winds a haulage rope  $1\frac{1}{8}$  inch in diameter which pulls the "trip" up the incline. A full day's work at Ocean No. 1 consists of 31 "trips" of 27 cars each. The other drum winds a tail-rope  $\frac{3}{4}$  inch in diameter which is attached to the end of the "trip" (or train) of cars nearest the mine. The grade of the inclined plane at the mouth of the mine is 12 feet in 100 feet and is steep enough close to the entrance of the mine for the empty "trip" going in to

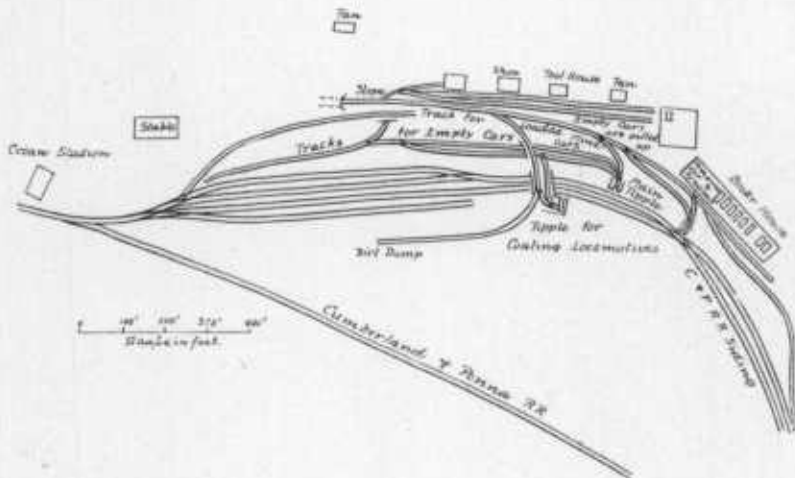

FIG. 36.—Sketch of Track Arrangement at Ocean No. 1, Consolidation Coal Company.

pull the haulage rope with it. As the inclined plane approaches the center of the coal basin the grades become less and finally are not sufficient for the mine cars to run by gravity so that a tail-rope is required to return the empty cars to the point in the main heading whence they are taken by a compressed-air locomotive weighing 30,000 pounds and distributed to the side entries. This locomotive is supplied with compressed air by a duplex three-stage Corliss compressor situated on the surface. The compressed air at a pressure

of 850 pounds per square inch is forced into the mine through pipes and the locomotive is charged from this pipe-line. One Ingersoll-Sergeant, one Sullivan, and two Harrison coal-mining machines were working in this mine in 1901, the power used to operate them being compressed air, which is supplied through pipes at a pressure of about 100 pounds to the square inch by a duplex Corliss air compressor 16 x 18½ x 36 inches stationed in the main power house on the surface. This air compressor also furnishes power to work two duplex Worthing pumps (12 x 14 x 10 inches), one Cameron pump 12 x 7 x 13 inches, and one duplex Jeanville pump 14 x 14 x 36 inches, all located within the mine. The plant includes a reserve straight line compressor 12 x 16½ x 36 inches for emergencies.

The ventilation of this mine as well as that of Ocean No. 8 is accomplished by two direct-connected Guibal fans with spiral casings. The larger of these fans has a diameter of 25 feet, the smaller 15 feet. A battery of eight return-tubular boilers (five of which are 60 inches in diameter and 16 feet long) supplies steam at a pressure of 100 pounds to the square inch to the tail-rope engine, the air compressor which charges the mine locomotive, the air compressor which supplies air to the pumps and mining machinery, and the two fans.

The coal is worked in this mine, as in nearly all of the mines of the Consolidation Coal Company, by the room and pillar system. A pillar of coal 50 feet thick is usually left between the parallel entries and the rooms are driven 12 to 14 feet wide, the point lines of the rooms being usually 55 feet apart so that a pillar of coal about 40 feet thick supports the rooms until the pillars are drawn. The length of rooms or the distance between each set of parallel side entries is usually about 500 feet. The mine cars used at Ocean No. 1 as well as Ocean No. 7 have a capacity of 5400 pounds of coal and weigh 1600 pounds when empty. The gauge of mine car track is 3 feet. The mine is mainly drained by the water tunnel which empties into Georges Creek three-fourths of a mile below the mouth of Ocean No. 1 and close to the entrance to the drift of Ocean No. 8.

*Ocean No. 2* of the Consolidation Coal Company is a drift on the western outcrops of the "Big Vein" and on the western edge of the town of Frostburg. The mine has no railroad connections and the coal is loaded into wagons for use as local domestic coal.

The capacity of the mine is 60 tons as a maximum. Ten men are employed, and three mules do the haulage of the mine. The coal is mined by pick-work exclusively. The ventilation is natural and the mine is drained by the other workings of the Consolidation Company that lie below it in the center of the basin. The gauge of mine car tracks is 3 feet and the cars weigh 1200 pounds empty and are loaded to contain a ton of coal.

*Ocean No. 3*, known also as the Hoffman mine of the Consolidation Coal Company, has its tippie on the end of the Eckhart branch of the Cumberland and Pennsylvania Railroad, a mile south of the Eckhart mine and like the latter is a slope on the eastern outcrop of the "Big Vein." Four hundred and sixty men and 23 mules were used in the operation of this mine in 1901 and the maximum daily output was 1500 tons of coal. A duplex stationary engine geared to a drum 6 feet in diameter winds a wire rope, which pulls the loaded mine cars up the slope and lands them on the surface. The empty cars return into the mine by gravity, pulling the rope in with them to the foot of the slope. Two compressed-air motors weighing 30,000 pounds each, bring the loaded cars to the foot of the slope and distribute the empties into the headings. Eleven compressed-air motors weighing 1000 pounds gather the cars in the rooms. The motors are supplied with air from the high-pressure compressor located at the Pumping Shaft. Eight pumps with an average capacity of 100 gallons per minute drain the mine and a direct-connected Guibal fan 20 feet in diameter constructed for either compressed or exhaustive ventilation furnishes it with air. Four return-tubular boilers 16 feet long and 60 inches in diameter supply steam to the fan pumps and stationary engine.

The usual pillar and room system is employed in this mine for

working the coal. Rooms are driven 12 to 14 feet wide. In the newer working of the mine the centers of the rooms are usually 100 feet apart, and 300 to 400 feet is left between each pair of parallel headings. In the older workings the rooms were driven with 35 feet between centers and the intervals between headings were greater. The coal is 9 feet thick and is mined exclusively by pick-work. The mine cars are loaded to contain 5400 pounds of coal and weigh 1600 pounds when empty. The gauge of tracks is 3 feet. The tippie consists of a balance eradle, the framework supporting it being of wood. A short tramway connects the mouth of the slope with the tippie.

*Ocean No. 3½.*—At Eckhart, 1½ miles east of Frostburg, the Consolidation Coal Company operate their Ocean mine No. 3½, a slope on the eastern outcrop of the "Big Vein." Ninety men are employed, three mules are used, and the daily output of the mine is 250 tons. A 14 x 30-inch double cylinder geared engine with a drum 6 feet in diameter and 3 feet wide pulls the loaded mine cars up an incline to the surface and drops the empty cars back into the mine. A tram road connects the opening of the mine with the tippie on the Eckhart branch of the Cumberland and Pennsylvania Railroad. The mine is supplied with air by a Guibal fan 16 feet in diameter with belt connection, constructed for either exhaustive or compressive ventilation. The haulage engine and fan are supplied with steam by two return-tubular boilers 15 feet long and 54 inches in diameter. No coal-mining machinery is used. The mine is drained by the pumps at the Pumping Shaft two miles southwest of the opening of the shaft. The workings of the Eckhart and the Hoffman mines join and frequently rooms are driven and the coal brought to the surface up the Hoffman slope while the coal from the pillars between the same rooms is shipped from the Eckhart tippie.

*Ocean No. 7.*—Ocean mine No. 7 of the Consolidation Coal Company is situated at the head of Woodland Run on a branch of the Cumberland and Pennsylvania Railroad about halfway between Frostburg and Lonaconing and a mile west of the center of the

Georges Creek coal basin. The coal operated is the "Big Vein," which in this mine is about 9 feet thick. In 1902 about 750 men were employed at this mine and 37 mules were used in the inside work. Three thousand eight hundred and eighty long tons of coal have been loaded at this mine in one day, over one tippie. The coal is mined from each side of the narrow valley or ravine in which the tippie and tracks are located. On the northwest side of the valley the coal is mined to the rise, a steam locomotive weighing 14,000

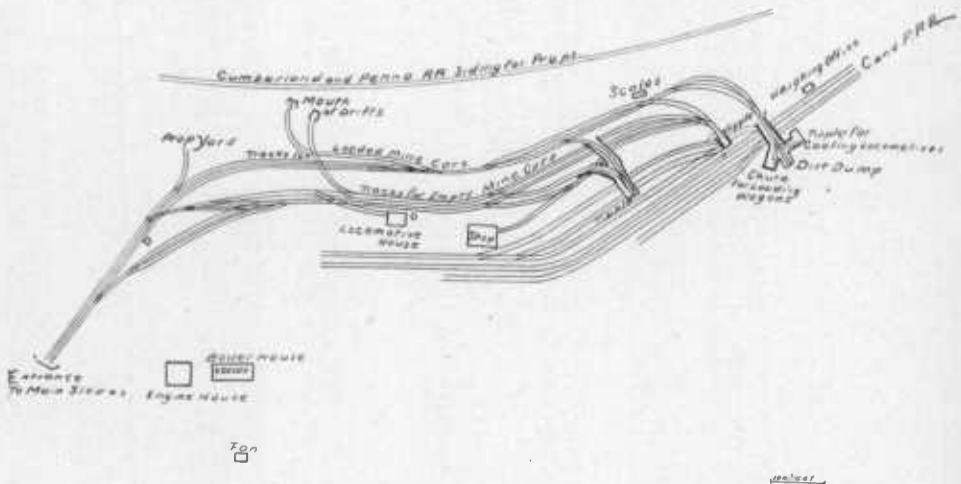

FIG. 37.—Sketch showing Track Arrangement, Ocean No. 7, Consolidation Coal Company.

pounds pushing the empty cars 1400 feet into the mine through one entry and the loaded coal cars running out to the tippie through another entry by gravity. The "Big Vein" coal that lies between these openings and the outcrop of the western edge of the coal basin is brought to the surface through these drifts. The main opening of this plant, however, is on the southwest side of the ravine and through it a large area of coal that lies to the dip is brought to the tipples. This main opening is made secure by a substantial brick arch of sufficient diameter for two mine car tracks to enter. A short dis-

tance inside of the mine the two tracks diverge, one passing under the other, descending in two directions to the south and southeast toward the workings of Ocean No. 1 and the center of the coal basin. The loaded ears are pulled in "trips" of 28 or 30 ears up the least steep of these slopes or inside ineline planes and landed just outside of the mouth of the mine, by an engine located on the surface operating a double drum and winding a  $1\frac{1}{8}$ -inch pulling rope. From the mouth of the mine the loaded ears run by gravity to the tipples. From the tipples the empty mine ears return towards the mine by gravity as far as they will run and then are taken in "trips" of 28 to 30 ears by a locomotive weighing 30,000 pounds up the grade to the mouth of the mine where a  $\frac{3}{4}$ -inch tail-rope is attached and the "trip" of ears is pulled into the mine and the cars hauled to the various headings, whence they are taken by the drivers with mules and distributed to the rooms. The loaded mine cars are brought up the steeper of the two inside slopes in "trips" of 17 or 18 ears and landed on the surface by another stationary engine operating a drum and winding a  $1\frac{1}{2}$ -inch rope. These loads are then hauled by the locomotive to a point where they will run by gravity to the tipples. From the tipples they are returned to the mines in the same manner as the cars from the other slope. The grade of the steeper inside slope is sufficiently heavy for the empty cars going down the slope to take the pulling rope in with them and a tail-rope is therefore unnecessary.

For ventilating the workings of Ocean No. 7 two direct-connected fans of the Guibal pattern with spiral casings are used, one having a diameter of 12 feet and the other 25 feet. They are constructed so that they can be used for either exhaustive or compressive ventilation. Steam is supplied to the stationary engines and fans by six return-tubular boilers, three of which are 50 inches in diameter and 14 feet long and three are 60 inches in diameter and 16 feet long. The mine is mainly self-draining through the water-level drainage tunnel that runs through the center of the coal basin and empties into Georges Creek below the mouth of Ocean No. 8 at Midland.



One pump only is used, having a capacity of 150 gallons of water per minute.

The coal from Ocean No. 7 is dumped into the railroad cars on the branch of the Cumberland and Pennsylvania Railroad over two

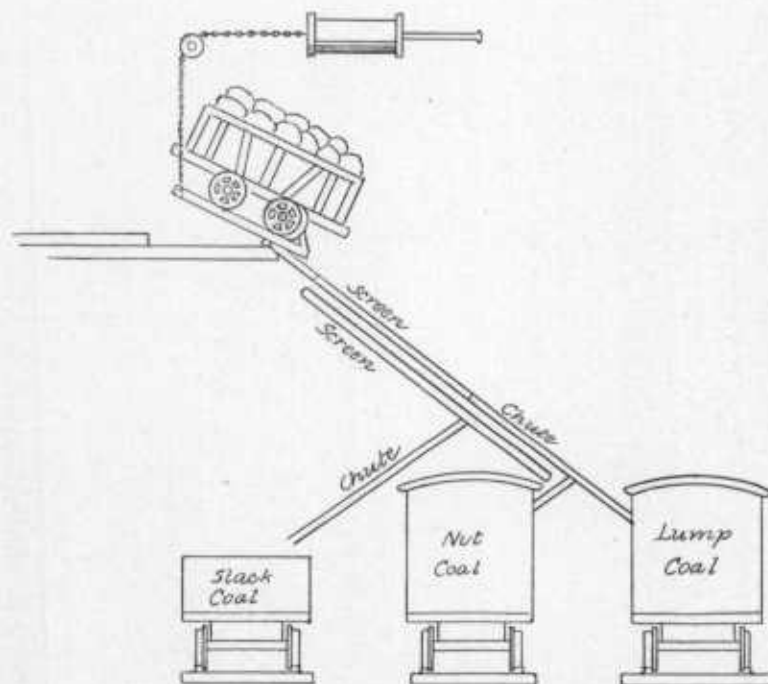

FIG. 38.—Sketch showing Main Tipple, Ocean No. 7, Consolidation Coal Company.

tipples, in addition to which the plant has a tipple for supplying locomotives with fuel as well as a tipple and chute for loading wagons with coal for local domestic use. The main tipple is constructed to screen the coal and load the lump and nut coal into two box cars at once, and the slack at the same time into a gondola or flat railroad car standing on a third track under the tipple.

The chute of this tippie is also furnished with folding steel iron flaps or doors which shut down and cover the screen when run of mine coal is to be loaded. When the screens are covered run of mine coal can be loaded into cars on either of the outside railroad tracks shown in the sketch but not onto cars on the middle track. The loaded mine cars are dumped at this tippie by means of a piston rod working in a cylinder operated by compressed air. To the end of the piston rod two chains are attached which pass over two pulleys or small sheaves and are fastened to each side of the hind end of the tippie. By this appliance the cars are raised and dumped onto the screen.

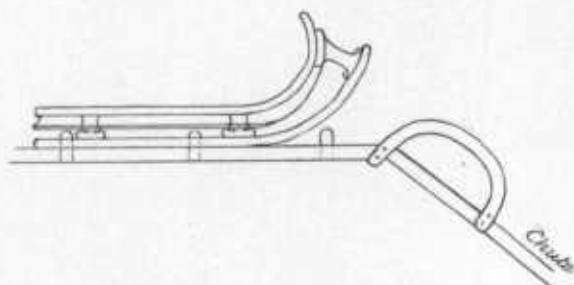

FIG. 39.—Sketch showing Rocker for Dumping Coal used by Consolidation Coal Company.

The three other tipples of this plant are of the rocker pattern, designed by Mr. B. S. Randolph, which is very simple in construction and effective in its action. The T-rails are bolted to two flat strap iron "rockers." As the car is run onto the tippie and strikes the horns, its momentum tips the rockers towards the chutes. The end gate of the mine car being latched by a lever projecting beyond the side of the car, the lever strikes an iron loop bolted to the side of the tippie. The end gate is unlatched and opens, allowing the coal to fall into the chute. The rocker is kept in place by iron pins in the frame, work underneath the rockers which fit into slots or notches in the rocker. The chute over which the run of mine coal is mainly loaded

is sprinkled with water from a pipe above to induce the coal to slide in it more freely.

The coal in Ocean No. 7 is mined both by pick and by coal-mining machines. Six machines were in use in this mine during the past year, all of them being the "puncher" type, one Harrison and five Fingersoll-Sergeant mining machines. Mine cars are of the pattern

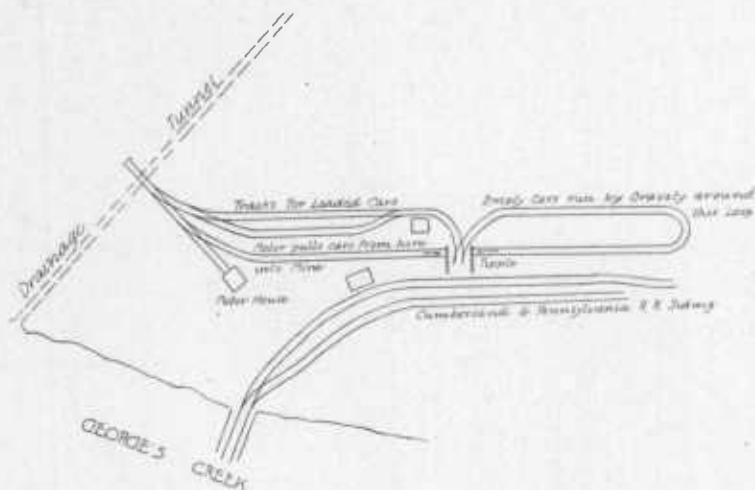

FIG. 40.—Sketch of Track Arrangement, Ocean No. 8, Consolidation Coal Company.

common to the Consolidation Coal Company, and the gauge of the mine tracks, as of all the plants of this company, is three feet. The rooms are usually driven in Ocean No. 7 with centers 65 feet apart.

*Ocean No. 8* of the Consolidation Coal Company has its tipples on a siding of the Cumberland and Pennsylvania Railroad on the west side of Georges Creek close to Midland station, the workings of this mine adjoining those of Ocean No. 1 and No. 4 of the Georges Creek Coal and Iron Company. The mouth of this mine is about three-fourths of a mile east of the middle of the coal basin and the main

heading, driven southwest nearly on the strike of the coal, takes out the coal that lies to the rise toward the east between it and the outcrop line formed by the erosion of the waters of Georges Creek. An area of coal adjoining this mine also on the east was formerly operated at this point by the Big Vein Coal Company. The present mine was opened and operated by the Consolidation Coal Company in May, 1902; in December of that year the daily capacity was 250 tons of coal. Fifty-three miners and twelve outside employees were engaged in mining and shipping this coal. A four-ton compressed-air motor is used to bring the coal from the interior of the mine to the tipple and the same motor is used to return the empty cars into the mine. The motor is supplied with air from the high-pressure compressor or locomotive charger stationed at the plant of Ocean No. 1. The mine is also ventilated by the fans of Ocean No. 1 and most of the water generated in the mine flows out through the workings of Ocean No. 1 into the main drainage tunnel which has its outlet to Georges Creek almost immediately underneath the entrance to the mine. The drainage tunnel was driven from Georges Creek at Midland about 700 feet through rock to tap and drain the "Big Vein" at the bottom of the coal basin. From the point where the drainage tunnel taps the "Big Vein" a water-level heading was driven through the basin and this heading now drains the Georges Creek Coal and Iron Company's mine No. 1 as well as Ocean Nos. 7 and 8 and the upper workings of Ocean No. 1.

*Frost mine.*—On the west side of the Cumberland and Pennsylvania Railroad at the head of the valley formed by Jennings Run and directly opposite Union mine No. 1 of the Union Mining Company, is the Frost mine of the Consolidation Coal Company. The tipple of this mine is within a few hundred feet of the lower end of the Y or switchback of the Cumberland and Pennsylvania Railroad and is located where the engines stop so that they can take on coal before switching into or from the Y. The tipple is chiefly constructed for the purpose of coaling engines. About 1000 feet of tram road con-

nect the mine with the tipple and horses or mules are used for haulage. Before coming upon the tipple the mine cars enter a long shed covered with corrugated iron and built upon trestle work. The cars are run into this shed and held in readiness for coaling locomotives. The coal mined is the "Big Vein" and is about 9 feet thick and the workings of the mine are in the direction of and partly under the town of Frostburg. Twenty men and three mules are employed and the daily capacity of the mine is 75 tons. The ventilation is natural and the mine is self-draining. The mine cars are of the style and capacity common to the Consolidation Coal Company.

*Upper Sewickley mines.*—At the upper end of the Y of the Cumberland and Pennsylvania Railroad a mile and a half northeast of Frostburg, the Consolidation Coal Company has opened a mine in the Upper Sewickley or Tyson coal seam for the purpose of coaling the locomotives of the Cumberland and Pennsylvania Railroad. Just south of Frostburg the company has an opening in the same seam to supply fuel to the town, and at Lord the boilers of the plant of Ocean No. 7 are fired by coal mined from an opening in the Upper Sewickley coal seam. The coal mined from these mines in the Upper Sewickley seam has proved very satisfactory for the purposes for which it is used but the company has not as yet put it on the market.

*Pumping station.*—In addition to the numerous mines it operates the Consolidation Coal Company maintains a pumping station for the purposes of draining portions of the company's mines which lie in the bottom of the basin. The pumping shaft is located at very nearly the axis of the basin, a mile and a half west of the mouth of Ocean mine No. 3 (Hoffman), the lower workings of which it drains. The shaft is sunk to the "Big Vein" and is about 250 feet deep. It has no railroad connections for shipping coal, although it is but a few hundred yards from the Cumberland and Pennsylvania Railroad. Only enough coal is mined and housed at the shaft to supply the boilers which operate the pumps and compressors located at this plant.

The coal from the shaft is shovelled from the mine cars into the

fire-boxes of the 6-ton return-tubular boilers 16 feet long and 60 inches in diameter with which this plant is equipped. About forty men are employed and two mules are used for haulage purposes. The equipment consists of a geared hoisting engine. One three-stage compound Norwalk air compressor, having a capacity of 500 cubic feet of air per minute, two straight-line compressors with capacities of 300 cubic feet per minute each and one duplex Corliss air compressor with a capacity of 1400 cubic feet per minute. The pumps installed at this plant are one duplex compound condensing pump with a capacity of 2500 gallons per minute, two duplex pumps with capacities of 1100 gallons per minute each, and one Cameron pump, the capacity of which is 300 gallons per minute.

UNION MINING COMPANY AND COMPANIES ASSOCIATED WITH IT.

The Union Mining Company, the New York Mining Company, the Barton and Georges Creek Valley Coal Company, and the Potomac Coal Company, for all of which the Black, Sheridan, and Wilson Company are the selling agents, operate the Union Mine No. 1, just north of Frostburg; Union Mine No. 2, a mile north of Frostburg; Carlos Mine No. 1, near Carlos; Carlos Mine No. 2, near Carlos; and the Potomac mine near Barton.

*Union No. 1.*—The plant of Union mine No. 1, operated by the Union Mining Company under lease from the Consolidation Coal Company, is situated on a siding of the Cumberland and Pennsylvania Railroad at the head of the valley of Jennings Run and on the northern limits of the town of Frostburg and not far from the northern end of the Georges Creek coal basin. The coal worked is the "Big Vein," which in this part of the region is ordinarily between 8 and 9 feet thick. In 1902 275 men were employed and 27 horses used for hauling, and the maximum daily output of the mine was 1150 tons of coal. The entrance to this mine is a drift a mile long through the old New Hope mine. A gravity plane 1200 feet long with 1½-inch rope is in operation in the mine, and tandem teams of

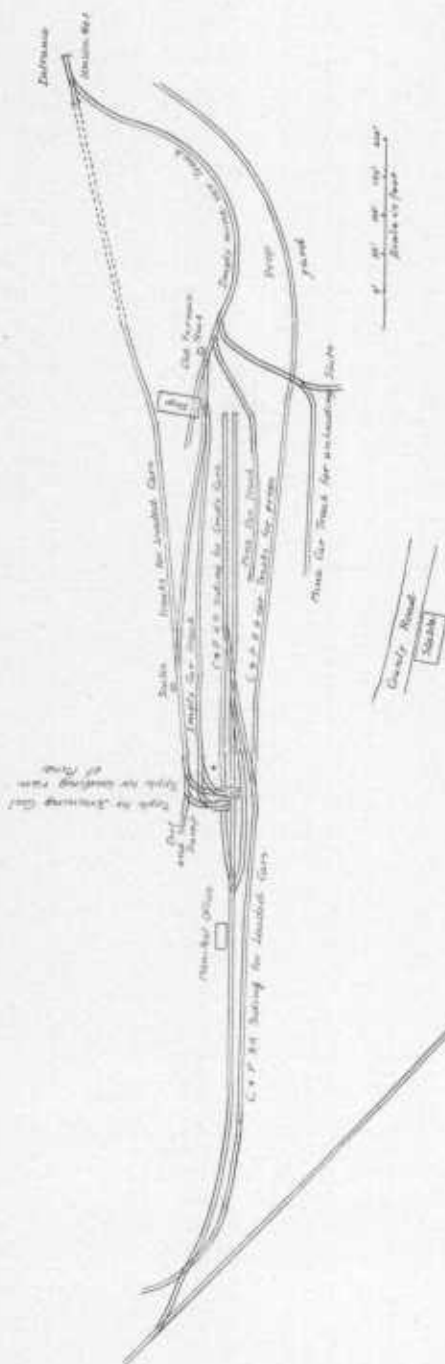

FIG. 41.—Sketch showing Track Arrangement, Union No. 1, Georges Creek Coal and Iron Company.

horses transfer the mine cars from the plane a mile inside of the mine mouth to the tipples and return the empty cars to the plane. Two tipples, side by side, load the coal into the railroad cars. One of these tipples dumps the coal onto a plain chute for shipping run of mine coal, the other passes the coal over a screen and separates the stock from the lump, loading the two grades of coal into separate railroad cars. Both tipples are of the ordinary T-rail pattern with back-balance weight attached, and at the tippie loading run-of-mine a Townsend pin-puller is used. The mine is self-draining and is ventilated by a fan 16 feet in diameter having a capacity of 18,000 cubic feet per minute and supplied by a 35-horsepower return-tubular boiler. The gauge of mine car tracks is 4 feet which is the greatest width of track used in the region. The mine cars weigh 2040 pounds empty and contain  $3\frac{1}{2}$  gross tons of coal when loaded. The coal is mined exclusively by pick-work.

*Union No. 2.*—On the east side of the Cumberland and Pennsylvania Railroad and the valley of Jennings Run, two miles northeast of Frostburg, the New York Mining Company operate their Union mine No. 2. In 1902 this mine was capable of producing 1400 tons of coal daily and employed over 400 men. The coal mined is the "Big Vein," about 8 feet thick with a slate band between the two benches, and is mined exclusively by pick-work. The mine has a double drift opening. Thirty-five horses are used for underground haulage and the coal is brought to the surface by tandem teams. The tippie, a Mitchell dump, on a siding or back switch of the Cumberland and Pennsylvania Railroad is close to the mouth of the mine. The drainage is natural. The mine is ventilated by two fans of 12 and 16 feet diameter, one supplying exhaustive and the other compressive ventilation. The gauge of mine track is 4 feet. The mine cars weigh 2040 pounds and are built to contain  $3\frac{1}{2}$  tons of coal.

*Carlos Nos. 1 and 2.*—At the end of the Carlos branch of the Cumberland and Pennsylvania Railroad a mile and a half west of the axis of the coal basin the Barton and Georges Creek Valley Coal Company operates Carlos mines Nos. 1 and 2, the entrance to which is



a slope in the "Big Vein" near the western edge of its outcrop. In 1902 the mines had a maximum daily output of 1100 tons of coal and 350 men were employed in operating them. The coal is brought to the surface up a slope 2400 feet long by a double 14 x 18-inch haulage engine winding a wire rope an inch in diameter on a drum (54 x 48 inches). A gravity plane 1200 feet long connects the mine with the tipple. For underground haulage two gravity planes 800 and 500 feet long respectively and 27 horses are required. No pumps are needed as the mines are naturally drained and no mining machinery is used. The ventilation is accomplished by two fans, which force air into the workings. The diameters of the fans are 16 and 10 feet respectively and their combined capacity is 3000 cubic feet of air per minute. The hoisting engine and fans are supplied with steam by three boilers, two of which are of a locomotive type and have a rated capacity of 50 horsepower each, and the third is upright and of 20 horsepower rated capacity. The gauge of mine car tracks is 4 feet and the mine cars weigh 2040 pounds when empty and hold 3½ tons of coal.

*Potomac mines.*—In 1903 the Potomac Coal Company opened a drift mine in the Franklin or "Dirty Nine-foot" vein on the south side of the valley of Moores Run, three-fourths of a mile east of Barton. The mine is developed to produce nearly 100 tons of coal per day and gives employment to about 25 men. Three mules are used. A short, steep gravity plane of three rails connects the entrance of the mine with its tipple on the Union Mining Company's (48-inch gauge) railroad. Over this tipple the small mine cars, holding about a ton of coal when topped, are dumped into larger cars containing about three tons of coal. The latter are run by a small locomotive to the tipple of the Union Mining Company's old Potomac and Barton "Big Vein" mines, on a siding of the Cumberland and Pennsylvania Railroad, one-quarter mile below Barton. The tipple is an old-fashioned rolling saddle that empties the tramway cars sidewise into the railroad cars by rolling the former over on their sides. In this mine the bottom bench of the "Dirty Nine-foot" seam is worked.

The bench varies from 22 to 36 inches in thickness. The mine is opened by a double-entry system. The rooms are intended to be 14 feet wide. In entries holes for shooting down the top are drilled in a thin layer of coal and the roof is blown down to give sufficient head room for men and mules.

Until the present year the Potomac Coal Company operated a mine in the Bakerstown or "Four-foot" vein on the south side of Moores Run just west of the mine just described. This mine in 1902 employed 75 men, worked 7 mules, and had a maximum output of 300 tons of coal daily. At present this mine is idle. A fan 20 feet in diameter, used compressively, ventilated the works and an 80-horsepower horizontal tubular boiler supplied the power to drive the fan. Small mine cars (1500 pounds capacity) were dumped over the tippie of the mine into the tram-road cars and transferred by the locomotive to the Potomac tippie. The mine lies just above the water-level of Moores Run and is naturally drained. The room and pillar system of mining is used. The rooms are 15 to 20 feet wide with a pillar of equal thickness between them.

#### THE GEORGES CREEK COAL AND IRON COMPANY.

The Georges Creek Coal and Iron Company now operate four drift mines in the Pittsburg seam or "Big Vein" and have lately opened two mines in the Upper Sewickley or Tyson seam. The "Big Vein" mines operated are Mines No. 1 and 4, a mile north of Lonaconing; Mine No. 3 or Pine Hill, one and a half miles northeast of Lonaconing; Mine No. 12, two miles northeast of Lonaconing; Mines No. 9 and 10 or Columbia, two and a half miles above Lonaconing. The Upper Sewickley mines are No. 16 and No. 17.

"*Big Vein*" Mines No. 1 and No. 4 of the Georges Creek Coal and Iron Company lie on the west side of the Georges Creek valley three-fourths of a mile north of the corporate limits of the town of Lonaconing. The entrances to the two mines are close together. No. 1 mine has connections with and tipples on both the Cumberland and

Pennsylvania and the west branch of the Georges Creek and Cumberland railroad. The coal from No. 4 mine is loaded only into railroad cars upon the tracks of the former road. In 1902 the daily capacity of mines No. 1 and No. 4 was 850 tons, and 170 men and 8 horses were employed. The coal is brought from the interior of the mines to the surface by a double tail-rope system operated by a stationary engine on the surface having four drums 6 feet in diameter and 3 feet wide and winding a  $\frac{7}{8}$ -inch hemp-center steel-wire rope. The engine is supplied by a 150-horsepower return-tubular boiler. At the mouth of the mines the tail-rope is disconnected and the loaded cars run themselves by gravity down an eight per cent grade to a landing near the tippie on the Cumberland and Pennsylvania Railroad, whence they are run by hand into the tippie. The empty cars, after being dumped, run from the tippie by gravity back towards the mines. The track on which they return is long enough to hold 30 empty cars at a time. This track is constructed with a sufficient grade so that the front car of each "trip" of 30 empty cars to be pulled into the mine will run to the place where the main pulling rope disconnected from the "trip" of loaded cars can be attached to it.

When mine cars from mine No. 1 are to be run to the tippie on the Georges Creek and Cumberland Railroad the tail-rope is disconnected from the front end of the "trip" of loaded cars when it reaches the mouth of the mine and in place of it one end of a "cut-off" rope or long link is attached to the front end of the "trip." The "cut-off" rope passes out the center of the track to a "bull wheel" near the tippie, around this wheel and returns along the side of the track to the mouth of the mine. The tail-rope, which is disconnected from the "trip," is attached to the other end of the "cut-off" rope, and the tail-rope then pulls the "trip" of cars to the tippie on the Georges Creek and Cumberland Railroad, taking the pulling-rope, which is still attached to the other end of the "trip," with it. When the "trip" of empty cars is brought back to the mouth of the mine by the pulling-rope, both ends of the "cut-off" rope are brought back to the mouth of the mine where it is disconnected from the

“trip” and tail-rope and the latter is replaced on the hind end of the “trip” going into the mine. The “cut-off” rope is thus left in position for connecting into the haulage system when needed. The main tippie of mines No. 1 and No. 4 on the Cumberland and Pennsylvania Railroad is a Mitchell tippie with an iron basket attachment. The coal is first dumped into the basket and then the basket

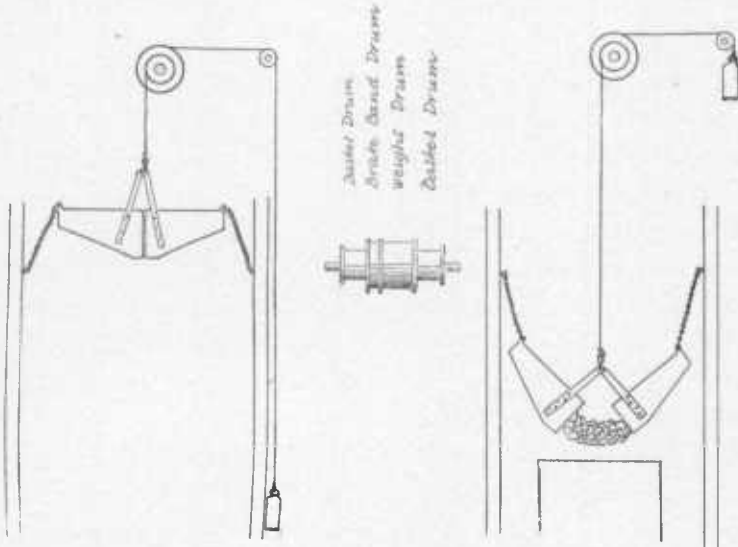

FIG. 42.—Sketch of Basket employed in Loading Cars by Georges Creek Coal and Iron Company.

containing the coal is lowered into the railroad cars, the main object of the basket being to prevent breakage of the coal and therefore obtain a greater percentage of lump coal. The basket is suspended by a wire rope wound around a drum. The weight of the coal from a mine car dumped into the iron basket causes the basket to descend, the drum is turned and another wire rope with a weight attached is wound upon a drum of larger diameter on the same shaft as the smaller drum. When the basket has been lowered to the desired height it is opened by chains which connect it with the framework

of the tippie. When the coal is emptied from the basket the weights attached to the rope of the larger drum wind the basket rope upon the smaller drum again and lift the basket up to the level of the floor of the tippie. The basket is controlled by a brake band on the larger drum which is operated by a lever. In addition to the Mitchell tippie the dump has also a chute for loading box cars. On the Georges Creek and Cumberland Railroad the tippie for loading the coal from mine No. 1 is of the ordinary frame back-balance pattern.

The entrances to mines No. 1 and No. 4 are close together and are very nearly at the center of the coal basin. Mine No. 1 reaches the coal that lies on the western slope of the basin and is self-draining while No. 4 is in that part of the "Big Vein" coal lying in the center of the basin and on its eastern slope. The grades in the latter mine are very irregular even on the general line of strike of the coal basin where one would expect to find a nearly uniform water-level grade. Mine No. 4 is partly drained by a connection with the Consolidation Coal Company's drainage tunnel and at present no pumps are needed for draining either of these mines.

Two fans of Guibal pattern of 12 and 20 feet diameter respectively furnish exhaustive ventilation to mines No. 1 and No. 4. The fans are supplied by steam from the same boiler that supplies the stationary haulage engines. The gauge of the mine car tracks used at these two mines is 3 feet and the cars weigh 1800 to 2000 pounds when empty and have a capacity of  $2\frac{1}{4}$  tons of coal. No coal-cutting or mining machinery is used in either of these mines or in any other of this company's mines in the Georges Creek region. The "Big Vein" coal is from 10 to 11 feet thick in these mines.

*Mines No. 9 and 10.*—On the east side of the Georges Creek valley between Midland Junction on the Georges Creek and Cumberland Railroad and the town of Midland is a series of drift openings known as mines No. 9 and 10 of the Georges Creek Coal and Iron Company. The capacity of the mines is 160 tons per day and 40 men are employed. The "Big Vein," about 10 feet thick, is mined from these drifts and the coal is shipped by the Georges Creek and Cum-

berland Railroad. The coal is brought to the tippie by two gravity planes 900 and 700 feet long. The main drift is at the extreme southern point of the coal outcrop on the hill above Midland Junction. The longer plane connects this opening with the tippie. The surplus power of the longer plane is utilized to bring loaded mine cars from two openings which are lower than the main opening up an incline to the top of the plane. A wire rope is connected with the rear end of the loaded "trip" going down the plane. The rope then passes around a bull-wheel and down the incline to the openings at the foot of the incline where the end of the rope is fastened to the ear to be brought up. The rope is carried down the incline by the empty ear, the rope acting as a brake to the ear in its descent down the incline. The shorter outside gravity plane is used to bring the coal from another drift close to the town of Midland to the tippie and a tram road 700 feet long connects the drift with the plane. The tram road has a grade of  $1\frac{1}{2}$  per cent in favor of the loads and the ears are hauled over it by horses.

The main mine has an inside gravity plane 900 feet long as well as an inside incline for lowering cars. The grade of the latter incline is not over 8 per cent and a single bull-wheel serves to run down the loaded ears and bring up the empty ones, the two being connected with a wire rope which passes around the wheel. A brakeman rides on each "trip" and the ears are controlled entirely by the brakes. Two ears are run in a "trip" on both the outside and inside planes and usually the same number of ears are run at once on the inside and outside inclines. The gauge of the mine ear tracks is 3 feet 6 inches and the mine ears weigh 1800 to 2000 pounds and are loaded to hold  $2\frac{1}{4}$  tons of coal. The drainage and ventilation are both natural. The coal is mined exclusively by pick-work. The usual room and pillar system of mining is used. The cover of the coal is not great and rooms are driven 14 feet wide with point lines 40 feet apart.

*Mine No. 3 or Pine Hill mine.*—Three-quarters of a mile to the east of the openings of mines No. 1 and No. 4 and on the opposite

side of the valley and railroads from them is mine No. 3 of the Georges Creek Coal and Iron Company, also known as Pine Hill mine. The coal worked is the "Big Vein," which is from 10 to 11 feet thick and has the same average section as the coal in mines No. 1 and No. 4. Seventy-five men and 7 horses are employed to produce a daily output of 250 tons of coal. At No. 3 mine the coal bed

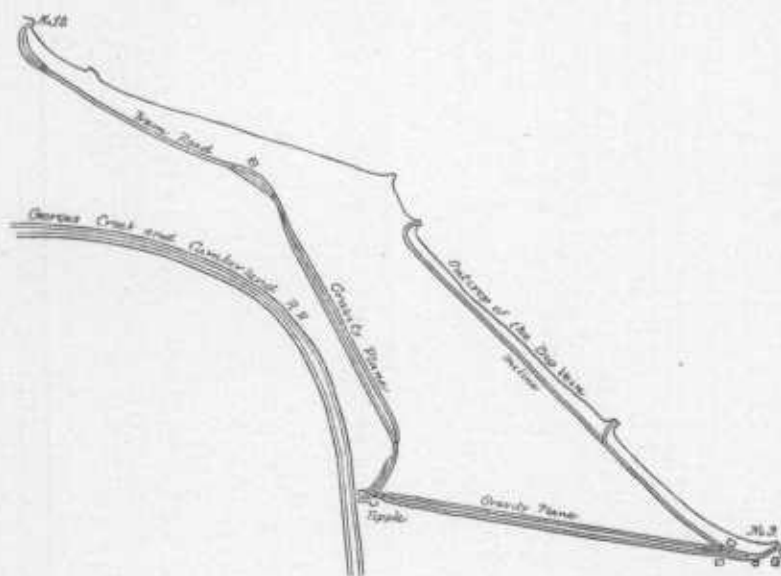

FIG. 43.—Sketch showing Track Arrangement, Union Nos. 9 and 10, Georges Creek Coal and Iron Company.

lies high up on the hill on the eastern rim of the coal basin and a rather steep gravity plane 1200 feet long connects the openings of the drifts with the tipple on the Cumberland and Pennsylvania Railroad. Two loaded ears descending bring two empty ones to the top of the plane. The grades of the coal bed within the mine are irregular and in many places, especially near the eastern outcrop, very steep and two inside gravity planes, one 600 feet long the other 1200 feet long are necessary to land the loaded mine ears inside of and near the mouth of the mines. From there they are transferred by

horses to the top of the outside plane. The drainage and ventilation are natural. The great difference in the elevations of the eastern outcrop and the western outcrop of the coal at the mouth of the drifts produces a natural draught more than sufficient for the requirements of the mine. The room and pillar system of mining is employed. The cover on the mine is not as heavy as of mines No. 1 and No. 4 and in mining smaller pillars are left between the rooms, the latter being 14 feet wide with centers 40 feet apart so that a pillar of coal of about 25 feet is left between them.

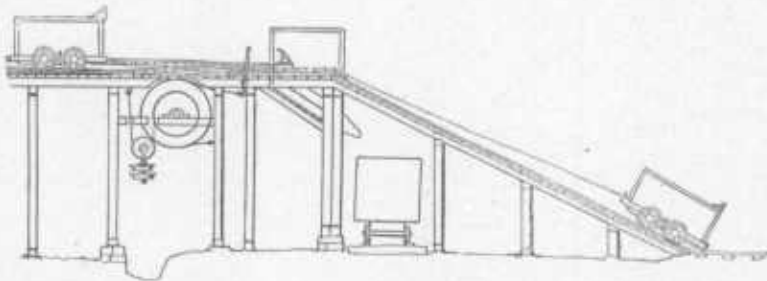

FIG. 44.—Sketch showing arrangement of Tipple and Prop-lift, Pine Hill, Georges Creek Coal and Iron Company.

In the workings of this mine along the eastern outcrop of the coal bed the grades are so steep that the loaded mine cars have sometimes to be let down to the headings with a wire-rope passing around a bull-wheel near the face of the room. The mine car tracks of this mine have a gauge of 3 feet 6 inches and the empty cars weigh 1800 to 2000 pounds and are loaded to carry  $2\frac{1}{2}$  tons of coal. The tippel is of the ordinary back-balance pattern with Townsend automatic pin-puller and dumps sidewise into the railroad cars.

The tippel has also an incline for raising props and mine timber, the surplus power of the loaded cars coming down the gravity plane being utilized to lift a mine car of props from the prop yard to the top of the tippel. This is accomplished by connecting the car to be raised by a wire-rope to the rear end of the empty "trip" going up



the plane. When the car of props or timber reaches the top of the tippie the "trip" is stopped, the rope disconnected both from the ear and the "trip." One end of the rope is then fastened to a double drum turning on one axle built beneath the tippie and the rope is wound back upon the drum by a weight which operates it. When the car is to be let down the short incline to be loaded with timber this rope is connected to it and the descent of the car is controlled by a brake band applied to the larger drum. As the car descends it winds the rope upon the smaller drum and lifts the weight that in its descent winds back the pulling rope upon the larger drum.

*Mine No. 12* of the Georges Creek Coal and Iron Company is a drift mine in a detached area of the "Big Vein" that lies on the east side of the Georges Creek valley near the eastern rim of the coal basin, midway between mines No. 3 and No. 9 of the same company. The mine is connected with the Georges Creek and Cumberland Railroad over which the coal from it is shipped, by a 4-rail gravity plane 2200 feet long. The tippie is of the usual plain chute type common to the region. This mine was opened and coal first shipped from it in 1903.

*Upper Sewickley or Tyson seam mines.*—*Mine No. 16* of the Georges Creek Coal and Iron Company is a drift opening in the upper half of the Upper Sewickley, Tyson, or "Three and a half-foot" seam on the hillside just above the opening of the drift of mine No. 1 ("Big Vein"). A retarding conveyor and washing plant for this mine has just been put in operation. The mine was opened in 1903 and the output is as yet limited. The plant of this mine, which has just been built, consists of three 150-horsepower horizontal tubular boilers. A 238-horsepower engine drives an electric generator, which in turn supplies the power for two stationary electric motors, one of which (of 40-horsepower) operates the endless rope of the retarding conveyor, the other a 30-horsepower motor runs the machinery that washes and elevates the washed coal from the washer to the storage bins.

The coal is brought from mine No. 16 to the tippie by the retard-

ing conveyor 1000 feet long. At the lower end of the conveyor the coal passes over a screen. The lump coal is loaded directly into the railroad cars and the screened coal is transferred by a screw conveyor to the washer. The washed coal is elevated into the storage bins from which it is loaded into cars on a siding of the Cumberland and Pennsylvania Railroad as it is needed for shipment. The electric generator also supplies power for a four-ton electric motor for haulage in mines No. 16 and No. 17. The mine will be equipped with a 12-foot Guibal fan, which will also ventilate mine No. 17.

*Mine No. 17* is a drift into the same coal bed as mine No. 16 and its entrance is on the hillside just above the mouth of the old drift of the Georges Creek Coal and Iron Company's "Big Vein" mine No. 4½. A short, steep gravity plane connects the mine with its tipple on the Georges Creek and Cumberland Railroad and a tramway 2200 feet long joins it with the retarding conveyor near mine No. 16. A four-ton electric motor transfers the coal from the mine to the conveyor over the tramway. The tipples of mines No. 16 and No. 17 are entirely independent of those used for loading coal from the "Big Vein" mines in their vicinity. A temporary wooden stack is used for ventilation. The interior workings of mines No. 16 and No. 17 will eventually meet and the haulage and ventilating systems of mine No. 16 will be extended into this mine.

A panel system of mining is employed in both mines No. 16 and No. 17. Rooms are driven in sets or panels of ten as the side entries advance. Each panel is separated from the next by a barrier pillar. The pillars between the rooms are drawn as soon as the rooms of each panel are up. After the pillars are drawn the haulage ways are retained by the necks of the rooms and a protecting stump which is left below the return airway of each set of entries.

The mine car tracks of mines No. 16 and No. 17 have a gauge of 42 inches and mine cars weighing 1000 pounds are used. Some of these are built entirely of iron but the bodies of the larger number of them are wooden.

## THE MARYLAND COAL COMPANY.

The Maryland Coal Company's mines are Kingsland, Appleton, New Detmold, and Patton, all of which are drifts on the western rise of the "Big Vein" near Lonaconing.

*Kingsland and Appleton mines.*—On the northwestern edge of the town of Lonaconing and on the west side of Koontz Run, which empties into Georges Creek at that town, are the Kingsland and Appleton mines of the Maryland Coal Company. The coal mined is the breast coal of the "Big Vein." One hundred and seventy-three turns or miners were employed in these two mines in 1902 and 42 other employees were engaged in hauling and handling the coal. The maximum daily output was 900 tons. The tippie on the west branch of the Georges Creek and Cumberland Railroad, close to the mouth of the Kingsland, serves for both the Kingsland and Appleton mines. A tram road (42-inch gauge) 2200 feet long connects the latter mine with the tippie. A long gravity plane inside of this mine lands the loaded mine cars in "trips" of 13 cars just outside of the Appleton mine, whence they are hauled by a locomotive weighing 10 tons to the tippie. A wire-rope of 1½-inch diameter is used in operating the gravity plane in the Appleton mine. The rope passes five times around a set of wheels of 6 feet and 4 inches diameter at the top of the plane and 13 loaded mine cars going down the incline lift 13 empty cars to the top of the plane. In the Kingsland mine horses alone are used for haulage. In both the Appleton and Kingsland mines the coal is mined to the "rise," the drainage of both is natural, and no pumping machinery is required. A Guibal fan 16 feet in diameter produces exhaust ventilation for the Appleton mine and a fan of the same pattern 12 feet in diameter ventilates Kingsland, a 40-horsepower boiler supplying steam for the former and a 10-horsepower boiler the latter. The main tippie loads endwise into the railroad cars while an auxiliary tippie close to the main one supplies coal to the locomotives of the Georges Creek and Cumberland Railroad.

The *New Detmold and Patton mines* of the Maryland Coal Com-



FIG. 45.—Sketch showing Track Arrangement at Appleton and Kingsland Mines, Maryland Coal Company.

pany are situated on the western side of the Georges Creek valley and of the coal basin, three-quarters of a mile southeast of Lonaconing. The tippie is at the end of the west branch of the Georges Creek and Cumberland Railroad and on the opposite side of the valley from the tippie of the Jackson mines of the American Coal Company. The coal from the Patton mine of the Maryland Coal Company is brought through the New Detmold mine to the New Detmold tippie. In 1902 180 miners and 40 other employees were engaged in mining and shipping coal from these two mines and 13 horses were used in hauling the coal, in addition to a tail-rope haulage system. The maximum daily output of the two mines was 1000 tons of coal. The coal operated

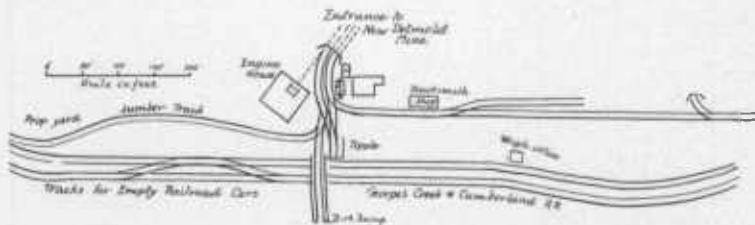

FIG. 46.—Sketch showing Track Arrangement, New Detmold Mine, Maryland Coal Company.

is the "Big Vein," which at this point of the Georges Creek valley lies high up on the hillside about the level of Georges Creek.

Only the breast coal is taken out of these mines and the props used are 8 feet long. The tail-rope system is operated by a 12 x 18-inch geared engine and 5-foot drum winding a  $\frac{3}{4}$ -inch wire-rope by which the mine cars are brought to and from the tippie in "trips" of 24 cars. The haulage engine is supplied with steam by an "Economic" boiler, both the engine and boiler being located in the engine-house close to the mouth of the mine and tippie. A Guibal fan having a diameter of 16 feet, driven by an "Economic" portable engine and situated about one-third of a mile northwest of the tippie and mouth of the New Detmold mine furnishes compressive ventilation to both the New Detmold and Patton mines. The coal is mined exclusively

by pick and no mining machinery is used. No pumps are required to drain the mines as they are self-draining. The mine car tracks at all the mines of the Maryland Coal Company have a gauge of 42 inches and the mine cars weigh 1600 pounds when empty and have a capacity of 500 pounds of coal. An ordinary back-balance tippie is used and an automatic pin-puller at the New Detmold mine. The tippie loads the coal sidewise into the railroad cars.

#### THE AMERICAN COAL COMPANY.

The American Coal Company operates the Jackson mine, near Lonaconing, and the Caledonia mine at Barton. At both of these plants the "Big Vein" is worked and at each of them one of the smaller seams overlying the "Big Vein" is mined, that at the Jackson mine being the Waynesburg, and that at the Caledonia mine the Upper Sewickley.

The *Jackson mines* of the American Coal Company are situated on the eastern side of the Georges Creek coal basin adjoining and southeast of Lonaconing. The main seam operated is the "Big Vein," which in the mines of this company is from 13 to 14 feet thick. The mine employed in 1902 about 260 men and 14 horses who are used to produce a daily output of 1000 tons of coal. A seam of coal lying above the "Big Vein" has also lately been opened and the coal taken from it now amounts to about 75 tons daily. In the main mine in the "Big Vein" a tail-rope system one mile and five-eighths long brings the coal to the mouth of the drift, whence it is conveyed by a 22-ton locomotive over a tram road one mile long to the main tippie at Lonaconing. The tail-rope employed consists of two drums 7 feet in diameter winding a  $\frac{1}{8}$ -inch haulage rope and a  $\frac{3}{4}$ -inch tail-rope. A Guibal fan 25 feet in diameter with a maximum speed of 90 revolutions per minute furnishes compressive ventilation for this "Big Vein" mine. The tail-rope engine as well as the fan engine are supplied with steam from two  $4\frac{1}{2}$  x 14-foot return-tubular boilers of 100 horsepower each. The mines, like all others

now operated in the Georges Creek basin south of Midland, are drifts. The drainage is natural and no pumps are required to dispose of the water. The coal is mined by pick and no mining machinery is used. In the "Big Vein" a mine car is used weighing when empty about 1850 pounds and holding about  $2\frac{3}{4}$  tons of coal when loaded. In the mine in the Waynesburg seam a mine ear containing about one ton of coal is used. The cars containing coal from the upper vein are let down by a gravity plane to the main tramway. The mine cars of this company differ from those generally used in the region in having a square body projecting over the wheels.

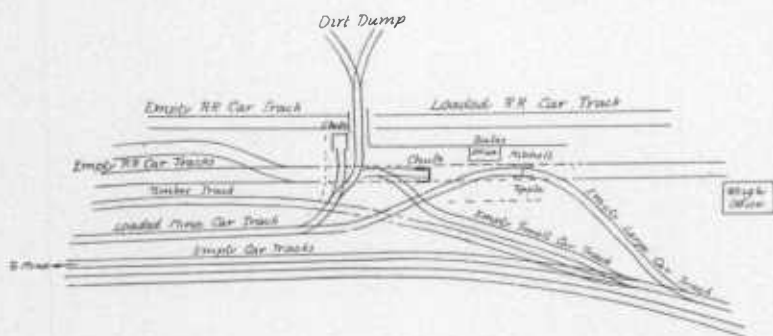

FIG. 47.—Sketch showing Tracks and Three-chute Tippie, Jackson Mine, American Coal Company.

The coal from the mine in the "Big Vein" is mainly dumped through a Mitchell tippie endwise into the ears on the siding of the Georges Creek and Cumberland Railroad. Some of it is, however, loaded sidewise and endwise into the railroad cars over two other plain chutes at the main Lonaconing tippie. The coal from the small vein is loaded into the railroad cars at the same tippie but is only dumped through the plain chutes and not over the Mitchell tippie. The coal seam at this mine is about 13 feet.

The *Caledonia mines*.—At Barton, four miles southwest of Lonaconing, the American Coal Company operate their Caledonia mines. Both the "Big Vein" and the Sewickley coal bed lying 110 feet

above it are worked by drift openings. The "Big Vein" lies high up on the hill on the west side of the Georges Creek valley and coal basin and a gravity plane 2700 feet long connects the main line with the tipple on the Cumberland and Pennsylvania Railroad and another plane 400 feet long lets down the coal from the mine in the Tyson or Sewiekley coal to the head of the main planes. The coal from both mines is lowered over the main plane and dumped over one tipple. A  $1\frac{1}{4}$ -inch wire-rope is used on the longer plane and a 1-inch rope on the shorter one. The thickness of the "Big Vein" at the mines, as given by Mr. J. H. Parrett, the general superintendent of the American Coal Company, is 13 feet 9 inches.

The maximum daily capacity of the "Big Vein" Caledonia mine for 1902 was 500 tons, 70 men and 6 horses being used in the production of the coal. The mine cars used weigh 1820 pounds when empty and contain when loaded  $2\frac{3}{4}$  tons of coal. The upper coal seam is about  $6\frac{1}{2}$  feet thick.

The greatest daily output of the mine in the Waynesburg coal bed is 150 tons of coal, and 34 men and 2 horses are employed. The mine cars used in the upper seam are very little smaller and lighter in weight than those used in the "Big Vein," the former having a capacity of two tons and weighing when empty 1780 pounds. The gauge of mine ear tracks is 3 feet. The ventilation and drainage of both mines is natural. No mine pumps, fans, or mining machinery are used or needed. The tipple is of the usual pattern, dumping sidewise into the railroad cars.

#### THE NEW CENTRAL COAL COMPANY.

*Koontz mine.*—The Koontz mine, operated by the New Central Coal Company, is situated a mile northwest of Lonaconing and has its tipple on a siding or spur of the west branch of the Georges Creek and Cumberland Railroad. Both the coals of the Pittsburg or "Big Vein" and of the Upper Sewiekley, lying 110 feet above it, are mined by drift openings on the east side of Koontz Run, opposite



and one-quarter of a mile above the Maryland Coal Company's Appleton mine. The coal from both beds is brought from the level of the mouth of the "Big Vein" to the tipple on the Georges Creek and Cumberland Railroad by a gravity plane 900 feet long. The main mine in the "Big Vein" is equipped with a tail-rope haulage system consisting of two return-tubular boilers 60 inches in diameter and 16 feet long, of 75 horsepower each. A double engine 14 inches by 24 inches geared  $3\frac{1}{2}$  to 1 is used to operate three drums, two of

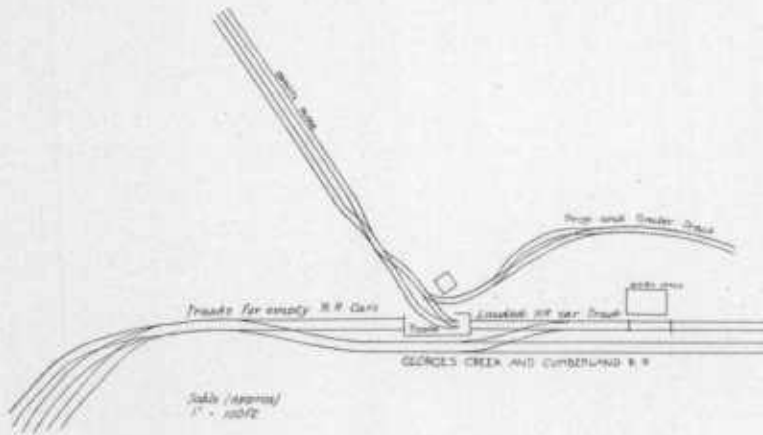

FIG. 48.—Sketch showing Tipple and Tracks, Koontz Mine, New Central Coal Company.

which are 4 feet in diameter and one 5 feet in diameter, which winds a main haulage rope of  $\frac{7}{8}$ -inch diameter and a tail-rope of  $\frac{3}{4}$ -inch diameter. The coal in the "Big Vein" averages  $9\frac{1}{2}$  feet thick and in the smaller vein above about 40 inches. The maximum daily capacity of the Koontz mine (in 1902) was 650 tons, and 140 men are employed in addition to 11 horses. The mines are ventilated by two fans of 20 and 10 feet diameters, having capacities respectively of 60,000 and 25,000 cubic feet of air pressure per minute.

Compressive ventilation is used. The mines are partly self-draining and partly are drained by the old workings of the Georges Creek

Coal and Iron Company which lie between this mine and the center of the coal basin. No pumps are used and no mining machinery, the coal being cut entirely by pick-work. The usual system of room and pillar work used throughout the region is employed for taking out the coal. Two sizes of mine cars are used, one for each coal bed mined. The cars in use in the "Big Vein" or main mine have a capacity of two tons five hundred weight of coal and weigh when empty 1700 pounds. The gauge of track of both mines is 42 inches. The tippie is of frame and the coal is dumped endwise into the railroad cars. The tippie has a plain chute furnished with an automatic and ingenious but rather complicated pin-puller. The Pittsburg coal seam at this mine is something over 12 feet.

Enough rock above the coal is taken down in the headings in the small vein to allow headroom for men and mules to pass under. In working rooms only the coal is taken out and the small empty cars are pushed by the miners from the heading to the working faces and when loaded are run by gravity to the headings. A tail-rope haulage system operated by a stationary engine, located on the outside, brings the mine cars from the side headings in the interior of the mine to the head of the outside gravity plane near the level of the drift mouths of the "Big Vein" mine.

#### THE CUMBERLAND BASIN COAL COMPANY.

At Barrellsville the Cumberland Basin Coal Company operates two mines in the lower Coal Measures. They also operate two mines across the State line in Somerset county, Pennsylvania. The latter mines are drifts in the "Rock Vein" and "Big Vein" coal beds. This company began opening these mines in 1902.

The *McGlone and Stafford mines*, as the mines in the lower Measures are called, are openings in the coal beds known locally as the Brookville or Bluebaugh and Clarion or Parker veins respectively, and are on the southeast side of the valley of the north branch of Jennings Run, half a mile northeast of Barrellsville. In these mines

is worked the coal of the two lowest workable coal beds known in the region. The mines are on the eastern rise of the Georges Creek coal basin syncline and close to the point where that syncline passes out of Maryland into Pennsylvania. The Stafford mine is a drift opening while the entrance of the McGlone mine is a short slope down from the level of the Clarion or Parker seam into the Brookville or Bluebaugh which is about 30 feet below the former seam at that locality. The slope strikes the Brookville coal bed just above the water-level line of the north branch of Jennings Run. The entrances of both mines pass through the workings of old mines which were worked many years ago before the "Big Vein" was commercially worked, and after passing through the old workings the development of the mine is by a series of double headings driven slightly to the rise of the line of strike of the coal beds. The coal from both mines is hauled by mules to a tipple which serves for the shipment of the output of both. The tipple is located across the north branch of Jennings Run from the mines on a siding of the Cumberland Basin Coal Company's railroad a half mile from the junction of the latter with the Cumberland and Pennsylvania Railroad. The mines are naturally drained into the north branch of Jennings Run and their ventilation is assisted by wooden stacks.

#### THE GEORGES CREEK AND BALD KNOB COAL COMPANY.

The Georges Creek and Bald Knob Coal Company during 1904 opened some drift mines in a detached area of "Big Vein" which formerly belonged to David Brailer. The mines of this company lie at the extreme northern end of the Georges Creek coal basin about two miles north of Mt. Savage. Three seams of coal have been opened and are ready for shipment. A steam locomotive delivers the loaded mine cars from the entrance of the mine to the head of a gravity plane down which they are run to the tipple situated on a spur of the Cumberland Basin Coal Company's railroad. The mines are naturally drained and ventilated.

## THE BORDEN MINING COMPANY.

Through their shaft at Borden Shaft station on the Cumberland and Pennsylvania Railroad the Borden Mining Company formerly operated a considerable area of the "Big Vein" which lay on the west side of the railroad, and in the center and on the western slope of the basin, while on its western outcrop the same company also worked the "Big Vein" through the drift of the Bowery mine.

The main "Big Vein" coal territory owned by this company in the vicinity of these two mines has been worked out and the company is not operating either of them now.

W. A. and Howard Hitchins lease from the Borden Mining Company and operate the *Borden mine*, a drift in the outcrop of the "Big Vein" at the northern end and western edge of the basin. The mine has its tipple on the Cumberland and Pennsylvania Railroad close to the tipple of the Frost mine and across the valley of Jennings Run and nearly opposite the tipples of Union mine No. 1. The coal is brought from the mine to the tipple over a long tram road and gravity plane.

## THE BRADDOCK COAL COMPANY.

The Braddock Coal Company in 1903 made an opening in the Rock Vein seam which is generally identified as the equivalent of the Upper Freeport coal. The opening is a double drift on the north side of Braddock's Run a short distance east of Clarysville. The tipple is on the Eckhart branch of the Cumberland and Pennsylvania Railroad and the coal is taken across the valley of Braddock's Run in buckets by an aerial tramway rope-haulage system. The loaded mine cars are first emptied into a storage bin near the mouth of the mine. From the bin the coal is loaded into buckets and transferred across the valley to the tipple as needed for shipment. The rope and bucket system is worked by an engine and boiler located near the mine. The mine has two entrances, one for loads to come out of the mine, the other for empty cars to return into it.

## THE FROSTBURG COAL MINING COMPANY.

The *Morrison mine*, now operated by the Frostburg Coal Mining Company, is situated at Morrison station of the Cumberland and

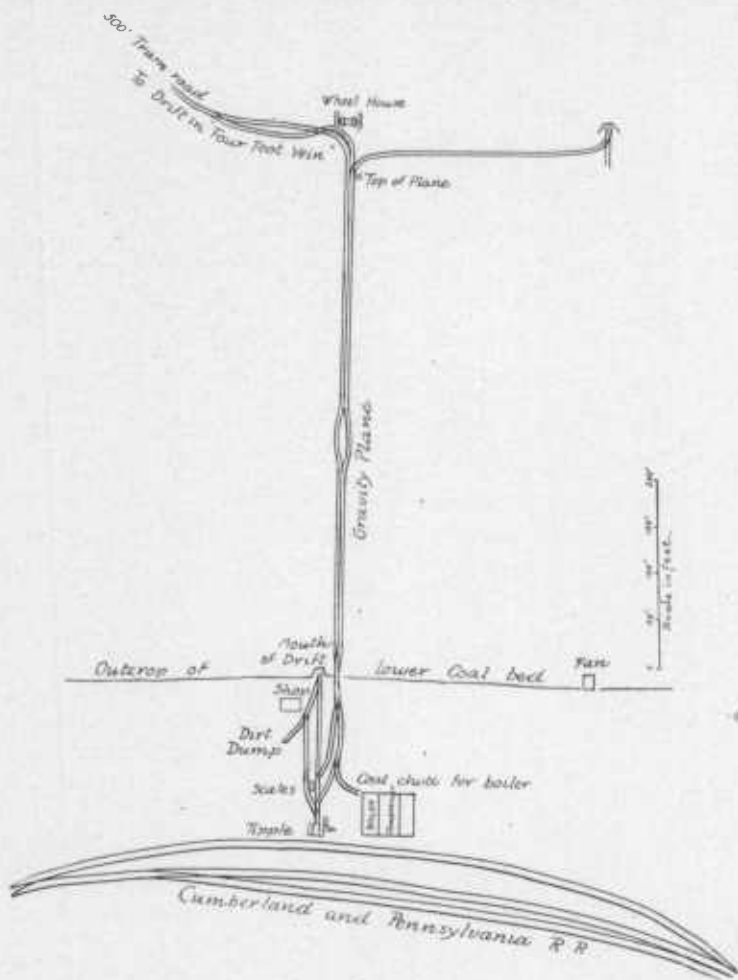

Fig. 49.—Sketch showing Tipple and Plane, Morrison Mine, Frostburg Coal Company.

Pennsylvania Railroad on the east side of the railroad and east of the axis of the coal basin. Two coal beds, the Upper Freeport and

Bakerstown, are worked by drifts and the coal brought to one tippie. The openings in the lower or Upper Freeport seam is 140 feet from the tippie and just high enough above it to afford an easy grade in favor of the loads from the mine to the tippie. In 1901 the maximum capacity of this mine was 100 tons of coal per day and 35 men were employed in it. In 1902 the upper coal bed was opened, and in 1903 the output was from both seams. A three-rail gravity plane connects the upper coal bed with the tippie. This upper coal bed is the one formerly worked by the Union Mining Company at their Potomac mine and in the mines of the Moscow-Georges Creek Coal Company at Barton, the lower coal bed passing under the level of Georges Creek between Barton and Morrison. The thickness of the upper coal bed varies in this mine from  $2\frac{1}{2}$  to 4 feet.

In these mines five Ingersoll-Sergeant coal-mining machines are used at times but usually only three of them are in operation at once. The coal-mining machines are operated by compressed air, which is supplied to them at a pressure of about 85 pounds to the square inch by an Ingersoll-Sergeant straight-line compressor with steam cylinder 22 x 24 inches and  $22\frac{1}{4}$  x  $24\frac{1}{4}$  air cylinder. The compressor is intended to run ten mining machines. The lower mine is ventilated by a fan 10 feet in diameter which forces the air into the mine. A 100-horsepower return-tubular boiler 16 feet long and 6 feet in diameter supplies steam to the air compressor and fan. The upper mine is naturally ventilated, assisted by a wooden stack at the opening on the north side of the wheel-house at the head of the plane. Both mines are naturally drained. The Deepwell pump (6 x 12 inches, capacity 500 gallons per hour) is used for cooling the compressor. The tippie is built of wood 20 feet high, of the pattern common to the region, with an additional chute beneath the main chute for loading box cars. When the lower chute is used the bottom of the upper or main chute is lifted out. The mine cars weigh 1000 pounds and have a capacity of 1900 pounds of coal. The gauge of mine car tracks is 42 inches.

## THE CHAPMAN COAL MINING COMPANY.

The *Swanton mine* at Barton, operated by the Chapman Coal Mining Company, is a drift opening in the Bakerstown or "Four-foot" coal bed, on the west side of the Georges Creek valley and coal basin. The tippie is on a siding of the Cumberland and Pennsylvania Railroad close to Barton station and about 600 feet north of the tippie of the American Coal Company's Caledonia mines. A short three-rail gravity plane connects the mine with the tippie. The coal worked in this mine is usually 26 to 28 inches thick, sometimes reaching to a thickness of 34 inches. The roof is good. The mine is naturally drained and ventilated. This company has also relaid the track of the old Swanton mine plane and reopened the "Big Vein" and is mining the coal near the outcrop which was not taken out by the Swanton Company.

## THE PIEDMONT AND GEORGES CREEK COAL COMPANY.

The Piedmont and Georges Creek Coal Company operates Washington mine No. 1, between Eckhart and Hoffman; Washington mine No. 2, at Eckhart; and the Tacoma mine, near Franklin.

*Washington mine No. 1* of the Piedmont and Georges Creek Coal Company is operated by the above company under a lease from the Consolidation Coal Company. The mine is a drift in the outcrop of the "Big Vein" on the south side of Braddock's Run between Eckhart and Clarysville.

*Washington mine No. 2* is operated by the same company under a lease from Charles Leatham (New York Mining Company?). The mine is a drift in the outcrop of the "Big Vein" at Eckhart.

The *Tacoma mine* of the Piedmont and Georges Creek Coal Company is a drift opening in the Lower Kittanning or "Six-foot" seam on the west side of the coal basin and of Georges Creek, on a lease from Mr. E. J. Roberts and others. The tippie is on a siding of the Cumberland and Pennsylvania Railroad a half-mile south of

Franklin station, just across the railroad from the tippie of the mines of the Cumberland and Piedmont Mining Company. The entrance to the drift is 104 feet from the tippie, a tram road connects the two and the elevation of the coal bed above the siding necessitates a chute 74 feet to the railroad to convey the coal from the tippie to the railroad. At the beginning of 1902 eighty-five men were employed and 6 mules were used in operating the mine, and the maximum daily output was 275 tons of coal.

The coal is mined by pick-work exclusively and the haulage effected by mules. A furnace ventilates the mine and a syphon of 2-inch pipe assists in draining it. The mule cars when empty weigh 1100 pounds and contain  $1\frac{1}{4}$  tons of coal. The gauge of mine car tracks is 42 inches. The coal in this mine is about 6 feet thick with a streak of bone coal a few inches thick near the top and a streak of sulphur in places near the middle of the seam with occasional rock faults and "clay veins." The usual room and pillar system of mining is employed. The rooms are driven 14 feet wide with pillars 25 to 30 feet wide between them.

#### THE MIDLAND MINING COMPANY.

The *Enterprise mine* on a spur of the Cumberland and Pennsylvania Railroad, a half-mile northeast of Midland, is operated by the Midland Mining Company (under a lease from the Consolidation Coal Company). The seam mined is the "Big Vein," which has about the same thickness as in the mines of Ocean No. 1. The coal is mined by two drift openings driven into the outcrop on the west side of Neff's Run. Seventy men and 7 horses were employed in the mine in 1902 and the maximum daily output of coal at that time was 240 tons. The loaded mine cars are hauled by horses from the mines to the tippie over a tramway 4000 feet long. The company is now installing a wire-rope haulage plant consisting of a single-drum 85-horsepower hoisting engine by which the loaded cars will be lifted to the surface up an incline 1200 feet long. The coal is mined by



hand pick-work. The mines are self-draining and no artificial appliances are used for ventilation. The gauge of mine tracks is 3 feet. The mine cars weigh when empty 1780 pounds and have a capacity of  $2\frac{1}{2}$  tons loaded. A plain tippie, having an iron T-rail back-balance, loads the coal sidewise into the railroad cars.

In 1903 the Midland Mining Company also opened a coal bed on Federal Hill a mile or more south of Mt. Savage on the Winfield Trumble tract. The coal in this mine is about four feet thick. This coal is claimed by some to be the lower bench of the Pittsburg bed, while others consider it to be one of the beds between the Pittsburg and the Franklin, or possibly the Franklin bed. Mules haul the coal over a tramway from the main opening to the head of a gravity plane, 1300 feet long, which delivers it to the tippie. The latter is on a siding of the Cumberland and Pennsylvania Railroad between Morantown and Mt. Savage.

#### THE PHOENIX AND GEORGES CREEK MINING COMPANY.

About a mile above Franklin station on the Cumberland and Pennsylvania Railroad on the west side of the railroad and of Georges Creek is the tippie of the Phoenix and Georges Creek Mining Company. This tippie is on a siding of the Cumberland and Pennsylvania Railroad. The siding branches from the main track and crosses Georges Creek one-quarter of a mile below the tippie. Both the "Big Vein" (Phoenix mine) and the "Four-foot" or Bakerstown coal beds (Eckhart mine, a new mine opened in 1904) are operated by this company with drift openings and the coal from both is brought to the one tippie. A three-rail gravity plane 800 feet long connects the opening in the Bakerstown coal bed with the tippie, and another three-rail gravity plane 1575 feet long brings the coal in "trips" of two cars from the "Big Vein" mine to the top of the lower plane, to which it is transferred and lowered, one car at a time, to the tippie. The improvements for this operation were put in in 1902. The coal is mined by the room and pillar system, the

rooms being 12 feet wide with 50 feet between points or centers. Props 11 feet long are used in the upper mine in the "Big Vein." No mining machinery is used. The coal beds operated by this company lie on the western pitch of the basin and the mines are naturally drained and ventilated. The cars used are of more modern construction and different from those common to the region. The sides are held together by strap-iron "binders" passing around the outside of the body of the car. The cars used in the "Big Vein" mine have a capacity of  $2\frac{1}{2}$  tons of coal and when empty weigh 1300 pounds. The gauge of tracks is 42 inches. The cars used in the Bakerstown seam are of similar construction to those used in the "Big Vein" mine. The tippie is the ordinary back-balance with frame trestle supports, and dumps the coal sidewise into the railroad cars.

#### THE PIEDMONT-CUMBERLAND COAL COMPANY.

This company operates two mines on the eastern side of the Georges Creek valley and coal basin. The coal from both mines is loaded over one tippie situated on a side-track of the Cumberland and Pennsylvania Railroad nearly a mile above the point where the Georges Creek empties into the north branch of the Potomac river. The "Big Vein" lying near the top of Hampshire Hill is worked at the Hampshire mine. The Lower Kittanning coal bed which lies not over 100 feet above the level of Georges Creek is also mined. A locomotive brings the coal over a long, narrow-gauge railroad from drift openings in the outcrop of the "Big Vein" on the northeastern side of Hampshire Hill to the top of a steep and long three-rail gravity plane down which it is run to the tippie. A short three-rail gravity plane parallel with the longer one connects the mine in the "Six-foot" seam with the tippie, the entrance to the latter mine being close to the top of the short plane.

#### THE MOSCOW-GEORGES CREEK MINING COMPANY.

The Moscow-Georges Creek Mining Company in 1902 opened and operated a drift mine in the Bakerstown or "Four-foot" coal bed on

the east side of the Georges Creek valley, a half-mile above Barton. The tippie of this mine, known as Moseow No. 2, adjoins the tippie of the Moscow mine of the Piedmont Mining Company and on the same set of sidings of the Cumberland and Pennsylvania Railroad as the latter. The ventilation and drainage are both natural. The coal is mined by pick-work. A short tramway connects the mine with the tippie. The coal bed lies slightly above the necessary tippie height, to overcome which the tippie has a long chute. The tippie is of the ordinary back-balance pattern and the tippie structure and

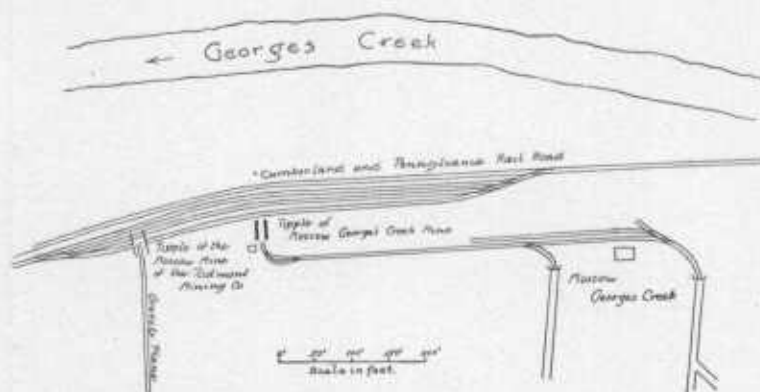

FIG. 50.—Sketch showing Track Arrangements and Tippie, Moscow Mines.

chute are of wood. The mine is at present idle on account of the workings going to the dip and the consequent inconvenience and expense of drainage.

The same company have also reopened the Pickell mine, renaming it Moscow No. 1, in the "Four-foot" seam on the west side of the Georges Creek valley immediately opposite the last-named mine. They have built a tippie but have not quite completed their connections with the Cumberland and Pennsylvania Railroad. The mine is now opened to ship 450 tons a day. The coal of the "Four-foot" bed in the mines of this company varies in thickness from 26 to 34 inches.

The Moscow-Georges Creek Company have also opened a drift into the outcrop of the old "Big Vein" Pickell mine, and connected it with their tippie on the west side of the valley by a gravity plane 1950 feet long. The company intends to build another plane from the top of the new plane to reach a knob of "Big Vein" that lies higher up on Pickell Hill.

#### THE CUMBERLAND-GEORGES CREEK COAL COMPANY.

On the west side of Georges Creek and of the coal basins one-half mile above Franklin station the Cumberland-Georges Creek Coal Company has a tippie on a siding of the Cumberland and Pennsylvania Railroad and operates the Penn mine, a drift in the Bakerstown or "Four-foot" coal bed. The thickness of the coal (in the mine) varies from  $2\frac{1}{2}$  to  $3\frac{1}{2}$  feet. A three-rail gravity plane 1300 feet long and a tram road from the top of the plane to the drift connects the mine with the tippie. In 1902 the mine employed about 50 men and shipped about 100 tons of coal per day. Two mules were used inside and on the outside tranway. An opening has also been made in the "Six-foot" bed close to the tippie and at, or slightly below, the water-level of Georges Creek, but this mine is not operated at the present time. It is the intention of the company to operate four mines over the one tippie. The one on the "Six-foot" coal bed at water-level to be called the Franklin mine, the one in the Upper Freeport or "Three-foot" seam next above called the Mooredale mine, the Penn mine which is now worked in the "Four-foot" seam, and the Ferndale mine in the Franklin or  $3\frac{1}{2}$ -foot seam above the "Four-foot." When in full operation it is expected that the daily capacity of the four mines, the coal from which will be dumped over this tippie, will be 1500 to 2000 tons. The coal in the drift now operated is mined by pick-work. The mine is self-draining and the ventilation is natural. A wooden air-stack without fire is used to produce a difference of level between the inlet and outlet of the air. The tippie is of framework covered with corrugated galvanized iron and

has two chutes loading the coal endwise. The sidings are long enough to contain 30 empty and 30 loaded railroad cars. The gauge of mine car tracks is 42 inches. The mine cars weigh when empty about 1200 pounds and hold one ton twelve hundred weight of coal.

#### THE PIEDMONT MINING COMPANY.

The Moscow mine of the Piedmont Mining Company is a drift opening in the outcrop of the "Big Vein" on the east side of Georges Creek and the coal basin. The tippie of the ordinary style of plain wooden structure, is on a side-track of the Cumberland and Pennsylvania Railroad, a half-mile above (northeast of) Barton. A gravity plane 1100 feet long connects the mine with the tippie. Fifty-one men were employed in 1902 and three horses used for haulage purposes to produce a maximum output of 500 tons per day. The drainage and ventilation are both natural and the coal is mined by pick-work exclusively. The gauge of mine car tracks used is 42 inches and the weight of cars averages 1817 pounds with a carrying capacity of 2 to 2½ tons of coal. The Bakerstown or "Four-foot" coal bed has also been opened but is not mined to any extent.

#### THE LONAONING COAL COMPANY.

The Lonaoning Coal Company operated the Shamrock mine in the "Big Vein" adjoining and just to the east of the town of Lonaoning. The coal of this mine is owned by the Consolidation Coal Company and leased by them on a royalty to the Lonaoning Coal Company. The Shamrock mine is in a knob high up on the extreme eastern edge of the Georges Creek coal basin. An outside inclined plane 1800 feet long connects the mine with the tippie on a siding of the Georges Creek and Cumberland Railroad. The grade of the coal seam being steep, the main heading of the mine for 1300 feet is a continuation of the outside incline plane. The total incline inside and out is 3100 feet of single track of 3½ feet gauge. A 75-horsepower double-cylinder engine with double-brake bands operates a

drum four feet in diameter which lets down 6 loaded cars at a time from the top of the inside plane to the tippie and lifts the same number of empty cars from the tippie to the top. Forty-four hundred feet of wire-rope  $\frac{7}{8}$ -inch thick is used to operate the haulage system of

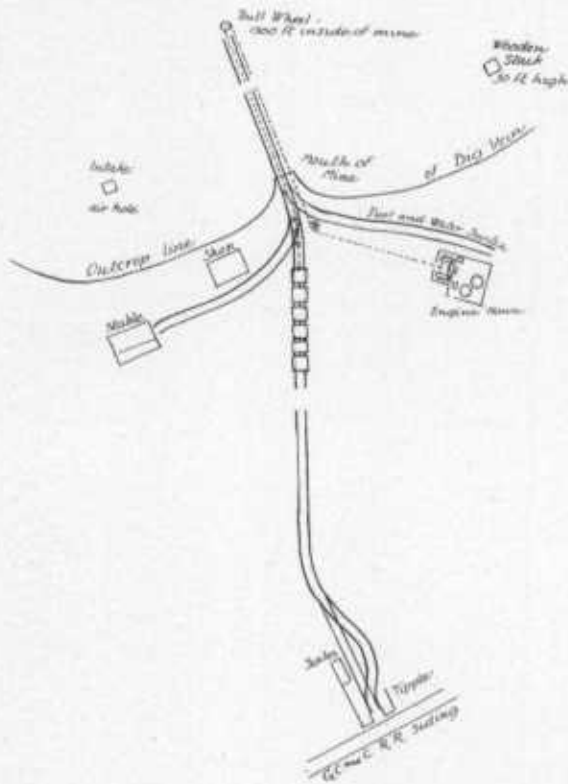

FIG. 51.—Sketch showing Plan of Haulage System, Shamrock Mine, Lonaconing Coal Company.

this mine. The steam for the haulage engine is supplied by two upright boilers of about 50-horsepower, one only of them being used at a time. The mine cars used at this mine are of the pattern most common in the region and weigh when empty about 1800 pounds and when loaded about  $2\frac{1}{2}$  tons. The average number of men em-

ployed in 1902 was 125 and the maximum daily output of coal 450 tons of 2240 pounds. Seven horses were used in hauling the coal to the top of the inside plane. The drainage and ventilation are both natural. For ventilating the workings a wooden stack 5 feet by 6 feet square and about 30 feet high produces a natural draught without the use of fire. No pumps are required. No coal-cutting machinery is used and the coal is all mined by pick-work. The tippie is side- and self-dumping with automatic pin-puller designed by George Townsend.

#### THE COROMANDEL COAL COMPANY.

The Coromandel Coal Company owns a drift mine in the outcrop of the "Big Vein" on the hill above and on the east side of the town of Lonaconing. The mine was formerly the "Big Vein" mine of the New Central Coal Company. The tippie on the east branch of the Georges Creek and Cumberland Railroad is close to the entrance to the mine. Twenty men and 3 horses were employed in 1901 and 1902 and the daily capacity of the mine was 120 tons. The ventilation and drainage are both natural and horsepower is used exclusively for haulage. The coal is mined by hand pick-work. The mine cars weigh 1760 pounds empty and hold two tons five hundred weight of coal. The gauge of tracks is 42 inches. The tippie is of frame, dumping sidewise into the railroad cars. At present this mine is idle.

#### G. C. PATTISON'S MINES.

On a siding on the main line of the Baltimore and Ohio Railroad a quarter of a mile west of Bloomington Mr. G. C. Pattison operates two mines under a lease from the Empire Coal Company and the Jones and Owens estates, and the coal from both is shipped over one tippie which has a separate chute for each mine. The opening in the Lower Kittanning or "Six-foot" bed is a drift 35 feet above the level of the Baltimore and Ohio Railroad and is connected with the tippie by a short tram road. Forty men were employed and 6 horses

used in this mine in 1902 and the maximum daily capacity was 200 tons of coal. The drainage is natural and the coal is mined exclusively by hand. The mine is ventilated by a small fan. Where the coal bed has its best development in this mine it shows a little over four feet. The roof is a fire-clay shale, varying in thickness from nothing to 18 inches, above this fire-clay is a strong sandstone. The bed is subject to squeezes in which the thickness of the coal is considerably reduced and a number of thin clay bands have been encountered in the workings of the mine.

The upper mine in the Bakerstown or "Four-foot" coal bed lies 410 feet immediately above the opening in the "Six-foot" bed, and is connected with the tippie by a gravity plane 1010 feet long. In this mine 25 men and 4 mules were worked in 1901 and its maximum daily capacity was 100 tons of coal. The thickness of the coal bed averages 28 inches with 15 inches of bone coal above it and about 5 inches of bone and shale below. The ventilation and drainage are natural and the coal is mined by pick-work. The mine car track gauge of both mines is  $3\frac{1}{2}$  feet. The mine cars weigh 1000 pounds when empty and contain  $1\frac{1}{2}$  tons of coal.

#### THE MONROE COAL MINING COMPANY.

On the opposite side of the Potomac river from Barnum station on the West Virginia Central Railroad, 8 miles above Westernport, the Monroe Coal Mining Company operates two drift mines on the western slope of the Potomac valley syncline. One of these mines is in the Lower Kittanning or "Six-foot" seam and was formerly known as the Barnum mine of the Watson-Loy Coal Company. The other mine is in the Bakerstown or "Four-foot" vein and was known until 1902 as the Loy mine of the last-named coal company. The river has been bridged and the coal from both mines is brought across to the tippie on the West Virginia Central Railroad on the West Virginia shore. The level of the opening in the "Six-foot" vein is just high enough to give a descending grade suitable for mule haulage



from the mine to the tippie. The "Four-foot" seam is high up on the hill above the river and required a gravity plane 1350 feet long and a tram road at the top of the plane to connect the mine with the tippie. Thirty men are employed in each mine, and four mules are used in each for haulage purposes, the maximum daily output of each being 150 tons of coal. The railroad siding has room for eight empty cars and will be extended to connect with the West Virginia Central Railroad above as well as below the tippie.

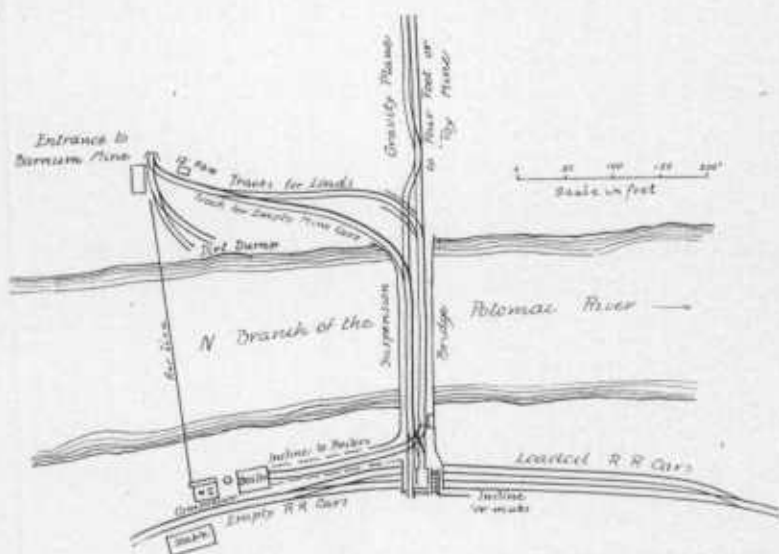

FIG. 52.—Tippie of the Barnum and Loy Mines, Monroe Mining Company.

The equipment of the Barnum mine consists of two horizontal boilers of 125 horsepower each. These supply an Ingersoll-Sergeant straight-line air compressor, which in turn operates five Harrison coal-cutting machines which are used in the mine in the lower "Six-foot" coal bed. The air compressor has a 24 x 36-inch steam chest and a capacity of 1400 cubic feet of air per minute. The boilers, compressor, and its receiver, the latter being 30 inches in diameter and 22 feet long, are located on the West Virginia shore near the

tipple, and the compressed air is conveyed across the Potomac river through a 6-inch pipe supported by a wire suspension bridge. The 6-inch pipe-line extends 500 feet into the mine in the lower "Six-foot" seam, where it is reduced to 4 inches diameter. Pipes 1½ inches in diameter lead into the rooms and supply air to work the coal-cutting machines. The coal in the upper or "Four-foot" seam is mined by pick-work. The coal for the boilers is run down a short incline from the tipple to the boiler house and the empty cars are hoisted up this incline and returned to the tipple by a small hoisting engine stationed in the boiler house. The engine winds a wire-rope which passes around a bull-wheel at the top of the incline.

Besides the main chute the tipple has an additional chute for loading wagons for local use. The main chute is constructed with a folding bottom which can be lifted or folded and the coal loaded into box cars on the second track of the railroad siding which passes under the tipple. In addition to the steps for the use of the men with which tipple structures are usually provided, the tipple of this company has an incline which is intended as a travelling way for mules to and from the mines.

The room and pillar system of mining is used in both of the mines of the Monroe Coal Mining Company. The main entries are 9 feet wide with pillars of coal 75 feet between the entry and the air courses. Branch entries are 15 feet wide with pillars of coal 30 feet wide between the parallel entries. Rooms are driven 45 feet wide with a track on each side of them and the slate and dirt is "gobbed" in the center of the rooms. The pillars between rooms are 45 feet wide.

The rooms are usually 300 feet long. Three hundred and forty feet is left between each pair of branch entries and a pillar of 40 feet is allowed to remain between the end of the rooms and the air courses to protect the latter until the pillars are drawn. In the "Six-foot" seam the height of the coal is sufficient to afford head room for men and mules without taking down the roof, while in the upper "Four-foot" seam two feet of the roof is taken down in headings. The coal seam in the Barnum mine is over five feet, with slaty part-

ings and some bony coal, while scarcely three feet of workable coal is found in the Bakerstown seam.

The workings of the "Six-foot" vein are ventilated by a fan 10 feet in diameter having a capacity of 40,000 cubic feet per minute. Compressive ventilation is used, the fan, however, is constructed to either exhaust the air from the mine or force it into it. A furnace and stack ventilate the mine in the upper "Four-foot" seam. Both mines have natural drainage. The gauge of mine car tracks is 42 inches. The cars used on the lower mine have a capacity of one ton fifteen hundred weight and weigh 1100 pounds when empty. Those used in the upper mine contain one ton four hundred weight and weigh when empty 900 pounds. The mine cars are constructed with four iron bands surrounding the body of the car. Those used in the lower or "Six-foot" bed have double brakes, those of the upper or "Four-foot" seam have single brakes.

#### THE UPPER POTOMAC MINING COMPANY.

The Upper Potomac Mining Company in 1902 made three drift openings in the Franklin or "Split-six" coal bed on the Maryland side of the north branch of the Potomac river. The tipple of these mines is on the West Virginia Central Railroad between Harrison and Schell stations. The coal is brought down a gravity plane and over the Potomac river by a bridge to the tipple. The latter has a plain wooden structure with the short chute characteristic of West Virginia Central operations, dumping endways into the railroad cars. The company have a number of miners' houses on the hill on the Maryland side of the river and mine from 20 to 25 tons of coal per day. The mines are naturally drained and ventilated.

#### THE DATESMAN COAL COMPANY.

At Stoyer station is a small operation (Alice No. 1 mine) belonging to the Datesman Coal Company. This is a drift in the Lower Kittanning or "Six-foot" seam. It is not worked continuously and was idle when visited.

## THE STOYER RUN COAL COMPANY.

*Stoyer No. 2 mine.*—A short distance up the West Virginia Central Railroad above the latter is Datesman mine which I believe belongs to the same company. This is likewise a drift in the Lower Kittanning or "Six-foot" seam which has a binder of some thickness in parts of the seam. It was worked some years ago but for the last ten years it has been idle more or less of the time. In 1904 it reported a daily output of 75 tons a day. The work is all pick-work, no machines being used.

## THE BLAINE MINING COMPANY AND GARRETT COUNTY COAL AND MINING COMPANY.

At Dill, between Blaine and Harrison, on the West Virginia Central Railroad, 19 miles southwest of Westernport, the Blaine Mining Company and the Garrett County Coal and Mining Company each operate a drift mine in the Lower Kittanning or "Six-foot" seam on the Maryland side of the Potomac river. The coal from these mines is run across a bridge over the Potomac river to a double siding on the West Virginia Central Railroad on the West Virginia shore. The bridge and tipple, although but one structure serving for the two mines, has double tracks, scales, and dumps so that the output of each can be weighed and loaded into separate cars on the railroad siding. The tipple structure is but 14 feet above the tracks of the railroad siding and has no chutes, the coal being dumped directly into the railroad cars. The sidings hold 8 empty and 8 loaded railroad cars for each mine.

The Blaine Mining Company's mine, lying about one-third of a mile west of the Potomac river, is connected with this tipple by a gravity plane 1125 feet long and a tram road 1100 feet in length, the latter being of easy grade and leading from the foot of the plane across the bridge to the tipple on the West Virginia side. At the landing at the foot of the plane the rope is disconnected from the

“trip” of four loaded cars and the “trip” is run into the tippie by gravity, controlled by a brakeman. The empty cars are returned to the bottom of the plane by a horse and driver. The drift opening

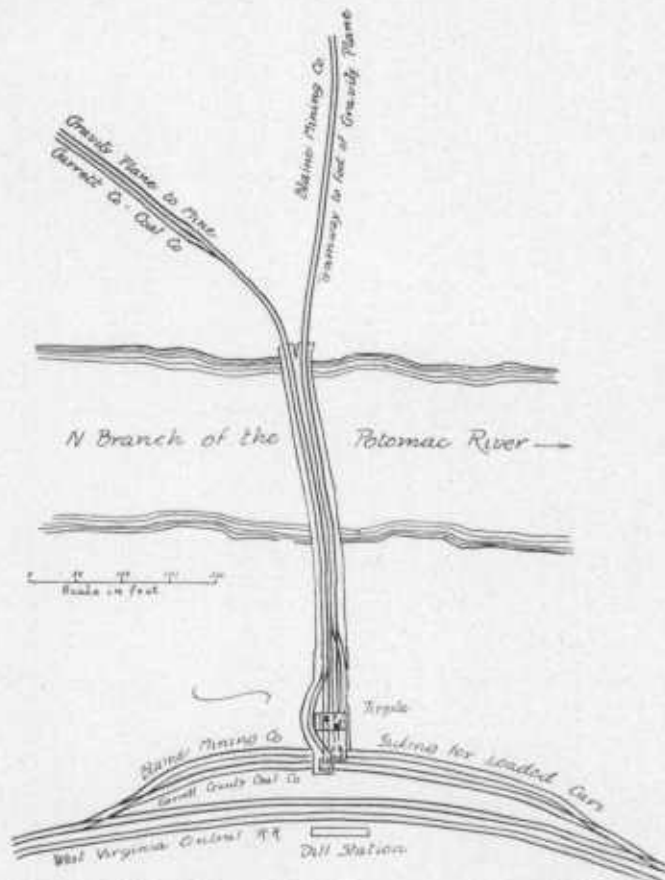

FIG. 53.—Tipples of the Blaine Mining Company and Garrett County Coal Company, at Dill.

is just far enough from the top of the plane to afford trackage room for cars. Sixty-five men and 6 horses are used in this operation to produce a maximum daily output of 200 tons of coal. The mine is a drift and the coal worked to the rise with entries and rooms in favor

of the loaded cars. The haulage is done by horses and the drainage is natural. Some heavy grades are encountered in the workings. The coal bed averages 5 feet in thickness with two slate partings about one inch thick dividing the coal bed into three nearly equal benches. The room and pillar system of mining is used. The double parallel entries have pillars 60 feet thick between them. The main heading is 10 feet wide. Branch headings are 16 feet wide and air courses 18 feet. Rooms are driven 18 feet wide and have pillars of 40 feet between them. The length of the rooms or the distance from one heading to the air courses of the heading is 300 feet.

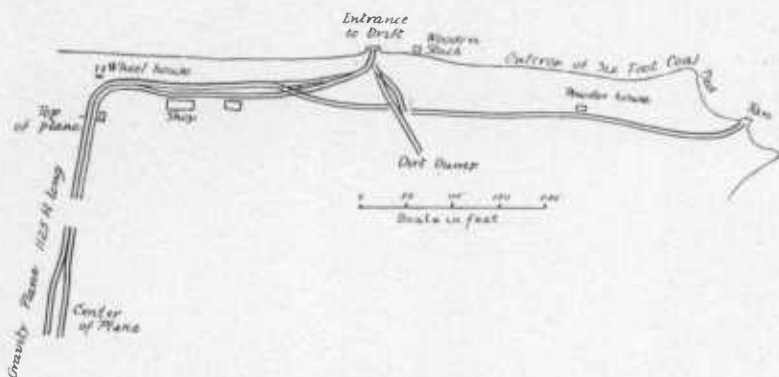

FIG. 54.—Track Arrangement of the Blaine Mining Company.

In the headings 12 to 15 inches of fire-clay rock above the coal bed is taken out and 10 to 12 inches of coal above the fire-clay so that the headings will average  $7\frac{1}{2}$  feet in height. The course of the main heading is  $N. 44^\circ W.$  That of butt entries to the right is  $N. 15^\circ E.$ , and of butt entries to the left  $S. 60^\circ W.$  The rooms are driven  $N. 44^\circ W.$  or parallel to the main entry. The coal is mined entirely by pick-work. The mine is ventilated naturally, assisted by a fan at the drift mouth 100 yards or more northeast of the main opening. The mine cars have a capacity of a ton and a half of coal each and weigh 1200 pounds when empty. They are constructed with three strap-iron binders, and most of them are furnished with double brakes, the bar

passing underneath and operating upon both wheels on each side of the car. The gauge of mine car tracks is three feet.

The Garrett County Coal and Mining Company's mine, known as Dill No. 1, is a drift opening in a tract of the Lower Kittanning or "Six-foot" seam, which lies along the frontage of the Maryland shore of the Potomac river. The mine is separated from the Blaine Mining Company's mine by a ravine which has cut out the coal bed and divided them into two distinct operations. A tram road leads from the drift to the top of the plane. The plane lands the loaded mine cars at the western end of the bridge alongside of the track of the Blaine Company, whence they are run over the bridge to the tippie by gravity and are returned to the bottom of the plane by horses. The plane has three rails and the gauge of the track is 3 feet. The coal bed is worked to the rise and the mine is therefore naturally drained and ventilated and the coal, which is of about the same thickness as that in the Blaine Company's mine, is cut by pick-work.

At Dodson, about a mile above Harrison on the West Virginia Central Railroad, the Garrett County Coal and Mining Company in 1902 operated a mine in the "Six-foot" seam on the Maryland side of the Potomac river where they have built a bridge across the river to bring the coal to a tippie on the West Virginia Central Railroad. The "Three-foot" or Upper Freeport seam at this locality shows 52 inches of coal and it is the intention of the company to operate it as well as the "Six-foot" seam. The company have built a number of miners' houses.

#### THE DAVIS COAL AND COKE COMPANY.

The Davis Coal and Coke Company operates a set of openings in the outcrop of the "Big Vein" on Franklin Hill, which lies between Georges Creek and Savage river. The openings are known as the Franklin, Scrap, and Buckhorn mines. The coal is brought to the tippie on the West Virginia Central Railroad about two miles above Piedmont, West Virginia, by a series of tram roads and gravity planes. The mine employed 80 men in 1902, and the maximum

daily production was 300 tons of coal. The thickness of the coal is 13 feet with a 2-inch slate parting about  $2\frac{1}{2}$  feet from the bottom of the coal bed. The mine is naturally drained and ventilated and the coal is mined exclusively by pick-work. Twelve horses are used for haulage purposes. The mine cars weigh when empty 1700 pounds and have a capacity of  $2\frac{1}{2}$  tons of coal. The gauge of mine car tracks is 42 inches.

The *Buxton mine*, operated by the Davis Coal and Coke Company, is a drift in the Lower Kittanning or "Six-foot" coal bed, on the east side of the north branch of the Potomac river at the mouth of Savage river, two miles above Westernport. The coal from both the Franklin and Buxton mines of the Davis Coal and Coke Company is brought across the Potomac river to the tipple on the West Virginia Central Railroad. From the Buxton mine the coal is lowered to the tipple and the empty cars raised to the mine over an inclined plane. The engine used for this purpose is supplied with steam by an 80-horsepower tubular boiler. The coal operated is about  $5\frac{1}{2}$  feet from the bottom of the coal bed with a streak of bony coal 4 to 6 inches thick about 8 inches from the roof. A "draw slate" from 2 to 4 inches lies immediately above the coal, above which there is a good roof.

One hundred and fifty men were employed in the Buxton mine in 1902 and the development of the mine was sufficient to produce 575 tons of coal, which is mined exclusively by pickwork. For underground haulage 18 mules were required. The mine cars weigh 1600 pounds when empty and have a capacity of  $1\frac{3}{4}$  tons of coal. The gauge of track used is 42 inches. For ventilation a fan, 10 feet in diameter, forces air into the workings. Two pumps, with capacities of 100 gallons per minute each, are used for drainage. The present daily output of the Buxton mine is nearly 1000 tons of coal.

At Henry, West Virginia, just across the Maryland line near the southeastern corner of Garrett county, the Davis Coal and Coke Company in 1901 and 1902 sank two shafts to the Thomas and the Davis coal beds, as the Upper Freeport or "Three-foot" and the Lower Kit-



tanning or "Six-foot" seams are respectively called by that corporation. An area of coal lying beneath the Maryland side of the Potomac river will eventually be worked from this plant, but as yet and for many years to come the workings of this mine will be confined to the coal which lies beneath the surface of the State of West Virginia. At this plant each of the above-named coal beds is opened to produce 500 tons of coal per day. When the mines in both seams are developed to their full capacity the company expect to hoist 4000 tons of coal daily from these shafts. At present only the upper or "Thomas" (Upper Freeport) coal bed is worked. The Upper Freeport coal bed at this mine has on an average 3 feet 3 inches of coal above which is a succession of thin strata of bone coal and soft coal to a total height of 5 feet from the bottom of the coal bed. Above this is a tough sand rock which makes an excellent roof. The Upper Freeport or "Thomas" coal lies 198 feet beneath the surface at the Twin Shaft (No. 2). It is reached and operated through two of the hoisting compartments of the Twin Shaft. The other two of the hoisting compartments of this shaft extend from the surface downward 419 feet to the Lower Kittanning or "Davis" coal bed. This coal bed has an average of 43 inches of coal in the lower bench and 30 inches in its upper bench. The two benches are separated by a binder of variable thickness.

No. 1 shaft has three compartments 7 x 12 feet, two hoistways, and one airway. The hoistways are used to raise and lower men and supplies to both seams. The shaft is 432 feet deep and is sunk 7 feet below the bottom of the Davis coal bed. Run-of-mine coal can be loaded on two railroad tracks from the tippie of Shaft No. 1. The latter is 100 feet from the shaft and is connected with the main boiler plant by a steel trestle. A lorrie, operated by a trolley, delivers coal over the trestle to the boilers. The boiler plant consists of six 150-horsepower steam tubular boilers and one Stilwell-Pierce and Smith-Vaile heater No. 5.

The power-house equipment is one Ingersoll-Sergeant straight-line compressor, 24 x 30 inches, which supplies air through a 6-inch pipe-

line to 11 Ingersoll-Sergeant coal-cutting machines. One Westinghouse generator, 75-horsepower, used for operating the conveying machinery of the tippie and for lighting the town. One Ballwood engine and a Bullock generator of 200 horsepower are used for running a 13-ton electric motor in mine. The hoisting engines of both shafts are run by steam, supplied from the boiler plant through 7-inch pipes which branch from the main 10-inch line. The hoisting engines of No. 1 shaft are geared and its winding drums are 7 feet in diameter and 3 feet wide. A geared clutch on one of these drums controls the length of rope and allows the engineer to lift at will from either seam with either cage. For shaft No. 2 of the main hoisting shaft, there are two sets of 24 x 36-inch direct-acting hoisting engines equipped with steam emergency brakes, safety hand brakes, and a steam reversing brake. The winding drums of shaft No. 2 are 7 feet in diameter and 8 feet long. At both shafts 1½-inch steel ropes are used for hoisting cages. Both mines are ventilated by a fan 13 feet 2 inches by 7 feet of Capell pattern. The fan is located at shaft No. 1, is driven by a 16 x 19-inch direct-connecting engine, and is constructed to either force or exhaust the air. The fan structure is of brick with a sheet-iron cover.

Two 16 x 9 x 18-inch Smith-Vaile pumps, operated by steam, lift the water from "sump" of the lower coal bed to the "sump" of the upper seam. One of these pumps is usually sufficient to keep the mine in the lower seam free from water. The second pump is only used in cases of emergency. At the "sump" of the upper seam, which is located close to shaft No. 1, two 24 x 12 x 30-inch Young pumps with 12-inch suction and 10-inch discharge are installed and lift the water of both mines to the surface. The capacities of each of the two last-named pumps is 600 gallons per minute, only one of them is now needed to keep the mine free from water.

The underground workings in both the Upper Freeport or "Thomas" and Lower Kittanning or "Davis" coal beds are developed upon the same plan. Near the shafts two sectional headings diverge 120° from each other. Off of the sectional headings butt

entries are driven with point lines 60 feet apart. Rooms are made 20 feet wide or the width of five cutting machine boards. A 13-ton electric motor is used for haulage in the mine in the Upper Freeport seam. The main underground motor tracks of this mine are laid with 56-pound T-iron and the mine cars are built to contain 1.7 tons of coal. The coal from the main hoisting shaft No. 2 first passes over a screen and is delivered into the picking tables where the slate is taken out by hand. The cleaned coal then is loaded into the railroad cars. The picking tables are run by electric motors at a slow speed. The slate taken from the coal on the picking tables is conveyed by belts to bins from which it is loaded into cars and taken to the slate dump.

# THE CHEMICAL AND HEAT-PRODUCING PROPERTIES OF MARYLAND COALS

BY

W. B. D. PENNIMAN AND ARTHUR L. BROWNE

---

## INTRODUCTORY.

It is the purpose of the present paper to give a brief outline of the investigations, whose results are tabulated in succeeding pages, and to give an explanation of the various terms employed in describing the chemical and heat-producing properties of the Maryland coals. The arrangement of the results by seams in each basin and the discussion of the samples in a geographic order from north to south was introduced to bring out whatever properties might be characteristic for a given seam or basin and to accentuate, if any such fact existed, the regularity of change in properties from one portion of a basin to another. A study of the tables shows that the coals of Maryland are remarkably similar whether they be considered by basins, seams, or geographic arrangement. Minor features have been noted, especially in the Pittsburg or "Big Vein" seam, but these changes across the basin have been so slight that local variations from single localities may obscure them and thereby render of no practical value the application of general changes.

## PREPARATION OF SAMPLES.

The preparation of samples for a testing of their chemical and heat-producing properties involves a careful selection of samples in the mines which shall represent the character of the seam as furnished to the market; and a thorough mixing and subdivision of the larger

samples to those suitable for laboratory tests in order that the results may represent average and not exceptional conditions. The samples were collected by geologists of the State Survey and prepared by the writers.

The method employed in obtaining the samples was as follows:

The visiting geologist had a groove cut from the top to the bottom of the seam, or part of the seam, from which a sample was desired. The material thus obtained by cutting such a groove was then sorted by hand, and the "bone" and "shale" usually rejected by the miner<sup>1</sup> was discarded. The rest of the material, representing the coal as prepared for the market, was then piled upon a clean floor, the large lumps were broken, and the whole well mixed and "quartered," two quarters being rejected. This mixing and "quartering" was repeated until there remained but a small bulk of coal. This was then placed in tight preserving jars, properly labelled, one jar being sent to the laboratory for examination, another jar being retained in the collections of the Survey as a record and protection against accidental loss of samples.

The samples thus furnished to the laboratory were prepared for final testing in the following manner: Each sample was put through a grinder and the crushed material was then thoroughly mixed and quartered until the coal was reduced to a quantity just sufficient for the various examinations.

#### ANALYSES.

The chemical properties of the coals were determined by analyses, which were classified as proximate and ultimate. The former give a close approximation of the heat-producing and commercial values of the coal, the latter the actual chemical constituents which go to make up the coal.

As the proximate analysis is the one employed in commercial transactions, all of the analyses made were of this type.

<sup>1</sup> This report, page 539.

## PROXIMATE ANALYSES.

The proximate analysis of coal is conducted in this country by an empirical method,<sup>2</sup> the following five determinations being made:

1. "*Moisture*," that is, the water present in the coal.
2. "*Volatile Carbon*," that is, the combustible material driven from the coal by heating to a red heat in a closed vessel.
3. "*Fixed Carbon*," that is, the combustible material which is not driven from the coal when it is heated to a red heat in a closed vessel.
4. "*Ash*," that is, the non-combustible mineral material remaining when the coal is completely burned.
5. "*Sulphur*," that is, the total amount of sulphur present in the coal.

These five determinations are made in the following manner:

1. A weighed amount of the prepared sample of coal is placed in an oven heated to a temperature of 220° F. to 225° F. and kept there one hour, during which time the moisture is driven off. The coal is then weighed, and the loss in weight, if any, is indicated as *moisture*. This moisture is indicated in the tables by the symbols " $H_2O$ ."

2. Another portion of the prepared sample of coal is weighed and placed in a weighed platinum crucible, which crucible has a closely fitting lid. This crucible, with the lid on, is heated to a red heat for seven minutes, during which the volatile gases are driven off, the sample and crucible are then cooled and weighed. The loss in weight is the moisture plus the volatile carbon; deducting from this loss in weight the moisture as determined above, the difference represents the *volatile carbon*. This is indicated in the tables by the symbols "V. C."

3. This same portion of coal after the moisture and volatile carbon have been expelled, is heated in the crucible, with the lid removed, until no more combustible material remains. The crucible is then weighed, the loss in weight representing the *fixed carbon*. This is indicated in the tables by the symbols "F. C."

<sup>2</sup> Report of the Committee on Coal Analysis, Jour. Amer. Chem. Soc., vol. xxi, No. 12, pp. 1116-1132, 1899.

4. From this last weight is deducted the weight of the crucible, the difference giving the weight of the *ash*. This is indicated in the tables by the symbol "A."

5. For the determination of the *sulphur* a third portion of the prepared sample of coal is weighed and mixed with sodium carbonate and magnesium oxide and burned to an ash. These chemicals retain all the sulphur in a condition readily estimated by suitable analytical methods. This sulphur is indicated in the tables by the symbol "S."

#### ULTIMATE ANALYSES.

The ultimate analysis of coal means the determination of the elements which enter into its composition. This is accomplished by burning the coal under suitable precautions for catching and measuring the various products formed and from the weights or volumes of these products the amount of each constituent is determined.

#### CALORIFIC OR HEATING VALUE.

The determination of the calorific or heating value of coal is made by burning a weighed amount of the prepared sample in a strong, closed vessel, called a "bomb," the latter being completely submerged in water. The heat produced by the burning of the coal is transferred to the water and the temperature of the water before and after the burning of the coal is then determined. The increase in temperature is a measure of the heat-producing power of the coal. This is a delicate operation, requiring complicated and expensive instruments.

The thermometers used in this work were standardized by the Physical Department of the Johns Hopkins University, using the hydrogen scale. All these determinations of heat values were made at room temperatures ( $15^{\circ}$  C. to  $25^{\circ}$  C.). The particular instrument used in these determinations was a calorimeter constructed for the Survey by Mr. Henry J. Williams of Boston.\*

\*New England Railway Club, meeting of Dec. 13th, 1898; Chas. L. Reese, Popular Science, Aug., 1899.

A brief description of this instrument and its use are set forth here. There are four principal parts to this instrument, which may be designated as follows: an outer double-walled vessel called the jacket, an inner metallic can called the calorimeter can, a revolving stirrer,

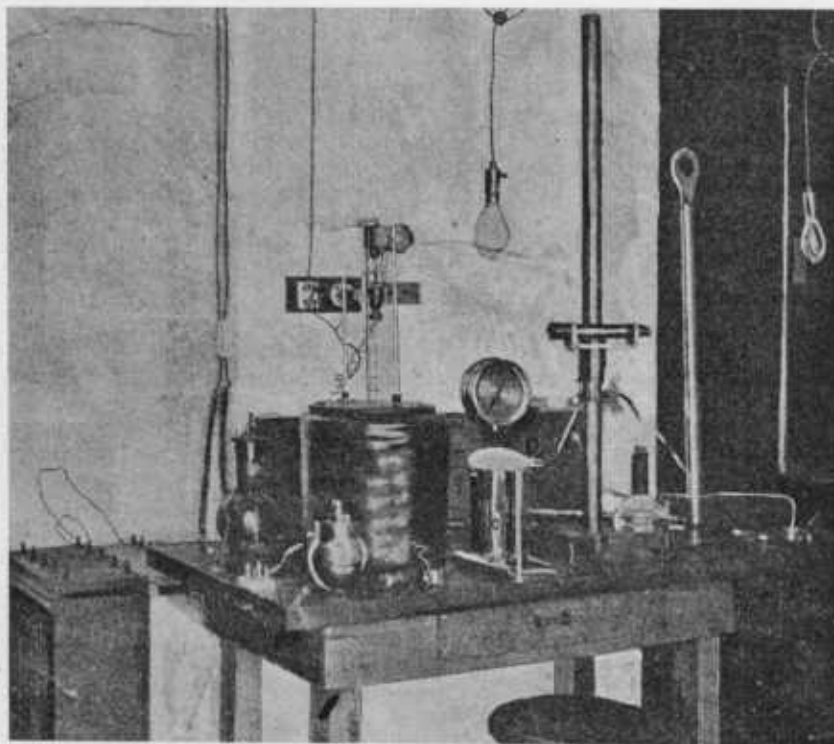

FIG. 55.—Williams' calorimeter and accessories used in testing the heating value of Maryland coals.

and the bomb. The outer double-walled vessel is about twelve inches in external diameter and seven inches inside diameter. It is covered externally by a layer of felt and oileloth, to guard against changes of temperature due to outside influences; there is a thickly padded top that fits over the whole. Between the walls of this vessel is water as a further protection against changes due to external influences.



The inner or calorimeter can is made of highly polished metal with a projection on one side to admit the stirrer. This can rests upon a tripod of non-conducting material, which lies within the jacket in such a way as to prevent contact between the calorimeter can and the outer vessel. The calorimeter can has a metallic lid, which, when placed upon it, leaves a space of about an inch between it and the inner wall of the jacket, thus giving to the contents of the can the further protection of this stratum of air.

The stirrer consists of two propellers placed upon a vertical shaft, rotated by an electric motor. This shaft passes down through the bottom of the cylinder, about five inches above an opening in the side of the cylinder. When the stirrer is set in motion the propellers lift the water from the bottom of the can and discharge it through the side opening of the cylinder, thus insuring thorough mixing.

The "bomb" is a hollow sphere, with a threaded neck, into which screws a top carrying a small check valve. This top is screwed into the neck of the bomb, upon a soft tin washer by a large lever wrench, until a gas-tight joint is made. The bomb is made of aluminium bronze to withstand high pressures, and lined on the inside with gold to prevent corrosion.

The use of this instrument in determining the calorific value of a coal is briefly as follows: A quantity of the prepared sample is compressed into a tablet, which is then accurately weighed and placed in a platinum crucible, a fine platinum wire being adjusted so as to touch this tablet of coal, when the crucible is suspended in the bomb. After the top of the bomb is screwed tight upon the tin washer, pure oxygen gas is admitted through the check-valve until the pressure of the gas inside the bomb reaches three hundred and fifty pounds per square inch. The bomb is then placed in the calorimeter can and a weighed amount of water poured around it. The stirrer is then adjusted and the covers of the can and jacket properly closed. A very sensitive, accurately standardized thermometer is passed through holes provided in the two covers, into the water in the calorimeter can, the stirrer is set in motion and the temperature of this

water is carefully taken, using a telescope to read the thermometer. Then by an electric current the fine platinum wire, which is in contact with the tablet of coal, is fused, thus igniting the coal. The heat due to the burning of this coal in the bomb causes an increase in the temperature of the water in the calorimeter can, which is accurately measured by reading the standardized thermometer. The amount of change in degrees multiplied by the quantity of water used plus the "water equivalent" of the instrument, which has been carefully determined by experiment, gives the calorific value of the coal when exactly one gram of coal is burned.

#### EXAMINATION OF THE ASH.

This is simply a chemical analysis of the ash giving its various mineral constituents. In the proximate analyses no detailed examination of the ash has been made, but the results of such examinations are given in the table of ultimate analyses.

#### RESULTS.

All the coals in Maryland of commercial value are *semi-bituminous* and are used for steaming and smithing purposes.\* They are all coking coals but, on account of their high value for steaming, are not used for making coke.

The ratio between the "fixed carbon" and the "volatile carbon" varies but slightly. The "moisture" is generally small, hence the value of the coal is almost entirely determined by the amounts of "ash" and "sulphur." The amounts of ash and sulphur are dependent to a large degree upon the care exercised in mining, though they vary in the different seams and in different parts of the same seam. The analyses furnish no data to explain these variations, nor can the part of the field from which the coal was taken be fixed by its analysis.

\*This report, page 239.

The calorific value (heating value) of a coal is expressed in calories, "C," or British thermal units, "B. T. U." A calorie is the amount of heat necessary to raise one gram of water one degree centigrade, the British thermal unit is the amount of heat necessary to raise one pound of water one degree Fahrenheit.

Therefore, in these tables when the heating value of a coal is given in calories it means that one gram of coal will heat that many grams of water one degree centigrade, while the "B. T. U." value means that one pound of coal will heat so many pounds of water one degree Fahrenheit.

The calorific value of a coal may be computed from its proximate analysis with sufficient accuracy for many commercial purposes by the following formula suggested by Goutal:<sup>5</sup>

$$P = 82C + AV.$$

In which *P* represents the calorific value.

*C* represents the percentage of fixed carbon.

*V* represents the percentage of volatile carbon, and

*A* represents a factor depending upon the proportion of volatile carbon in the coal.

These factors are given in the following table:

Coals containing Volatile Carbon . . . .	5%	10%	15%	20%	25%	30%	35%	38%	40%
Corresponding Value of <i>A</i> in Calories.	145	130	117	109	103	98	94	85	80

It has been found that the above formula is correct to within a few per cent in the majority of coals, but as it does not give correct results upon some coals, it is not, therefore, considered entirely reliable.

It will be noticed that the volatile carbon has a higher calorific value per unit than the fixed carbon except in the highly bituminous coals.

<sup>5</sup> Ann. de chim. Anal., 1903, vol., viii. 1-4. Reviewed in The Analyst, vol. xxviii, 1903, p. 128.

The value of a coal for raising steam in an ordinary boiler is not entirely determined by the total number of heat units set free during combustion but is dependent largely upon other factors, the chief of which is that in burning a highly bituminous coal there is a greater loss of heat due to a part of the volatile matter passing up the stack as smoke and unburned hydrocarbon gases than in a coal containing less volatile carbon. Furthermore, these highly bituminous coals are likely to cause a deposit of soot which reduces the efficiency of the heating surfaces. In consequence of these and other considerations the loss of heat, when using highly bituminous coals, will commonly reach forty-five per cent or more, while, when using the best anthracite, this loss approximates twenty per cent.

The use of anthracite has the additional advantage of freedom from smoke, but has some disadvantages, the chief of which probably is the greater amount of ash occurring in small sizes of anthracite used for steaming. The bituminous coal has the advantage of quicker combustion, thus enabling a quicker raising of steam, less ash, and a higher heating value per unit of combustible, which facts render it superior to anthracite when used under the boiler.

TABLE OF ANALYSES OF MARYLAND COALS.  
(ARRANGED BY BASINS, SEAMS, AND GEOGRAPHIC POSITION.)  
ANALYSES OF SIDELING HILL COALS.

*Pocono Coals.*

Mine	Collected by	See page	Chemical Composition					Calori- metric value calories	Calori- metric value B. T. U.
			H <sub>2</sub> O.	V. C.	F. C.	A.	S.		
Lonie Mizelle .....	Martin	...	0.92	8.73	35.73	54.63	.84	....	....
			1.10	7.10	45.00	45.90	.22	....	....

## ANALYSES OF GEORGES CREEK COALS.

*Upper Sharon Coals.*

Outcrop below Piedmont .....	Martin	323	.55	16.12	77.26	6.07	1.80	....	....
Outcrop 1 mile below Westernport .....	Martin	324	.38	16.16	70.73	12.73	5.68	....	....
Outcrop below Piedmont .....	Martin	...	.95	15.22	74.08	9.75	.59	....	....
Average composition .....			.55	16.12	77.26	6.07	2.52		

*Brookville Coals.*

Opening near Barrellville .....	Rutledge	328	1.15	15.93	72.77	10.15	2.21	....	....
Fairweather & Ladue, ½ mile S. Barrellville. Opening, Winters Run:	Rutledge	328	.85	17.71	71.60	9.84	1.16	....	....
(top) .....	Rowe	320	1.01	21.93	65.23	11.83	.83	7540	13,572
(breast) .....	Rowe	...	.85	22.44	67.44	9.27	1.08	7713	13,883
(bottom) .....	Rowe	...	.56	20.07	63.93	15.44	1.01	7260	13,068
Montell Tunnel, Loarville .....	Rutledge	330	.59	19.73	72.35	7.23	1.65	....	....
Opening, W. bank Warrior Run .....	Rutledge	331	1.10	22.55	70.70	5.65	1.86	....	....
Opening, W. bank Warrior Run .....	Rowe	331	.45	22.93	66.11	10.61	1.79	7783	14,009
Opening, W. bank Warrior Run .....	Rowe	331	1.45	21.74	65.97	10.84	1.43	7588	13,658
Opening, W. bank Warrior Run .....	Rowe	331	.87	22.98	70.43	5.72	.66	8089	14,560
Opening, W. bank Warrior Run .....	Rowe	331	1.21	23.36	70.67	4.76	.62	8135	14,643
Average composition .....			.91	21.04	68.83	9.22	1.80		
Average of those upon which calorimetric values were made .....			.91	22.02	67.12	9.77	1.06	7720	13,912

*Clarion Coals.*

Cumberland Basin Coal Co., Barrellville.....	Rutledge	332	.88	16.77	78.15	4.20	2.15	....	....
Cumberland Basin Coal Co., Barrellville.....	Rowe	332	.94	18.34	76.50	4.22	.95	8282	14,908
Cumberland Basin Coal Co., Barrellville.....	Rutledge	332	1.09	17.46	76.79	4.66	4.81	....	....
Opening J. O. J. Green, Westernport.....	Rutledge	332	.75	19.93	67.98	11.34	2.08	....	....
(top) .....	Rowe	332	.88	19.60	71.08	8.94	1.85	7918	14,252
(bottom) .....	Rowe	332	.36	20.09	72.94	6.61	1.28	8122	14,619
Opening Davis C. & C. Co., Westernport.....	Rutledge	332	.37	20.08	61.25	18.30	6.24	....	....
Average composition .....			.68	18.89	72.10	8.33	2.69	....	....
Av. of those determined calorimetrically.....			.56	19.34	73.51	6.59	1.19	8107	14,598

*"Split-Str" Coals.*

Opening old Gorman tipple, Franklin.....	Rutledge	333	1.40	15.84	71.18	11.58	2.77	....	....
Opening Piedmont & G. C. C. Co., Franklin..	Martin	333	.90	16.69	69.22	13.19	4.70	....	....
Opening Piedmont & G. C. C. Co., Franklin..	Dunn	333	1.72	17.80	69.42	11.06	4.31	....	....
Average composition .....			1.34	16.78	69.94	11.94	3.93	....	....

TABLE OF ANALYSES OF MARYLAND COALS.—Continued.  
ANALYSES OF GEORGES CREEK COALS.—Continued.  
*Lower Kittanning Coals.*

	Collected by	See page	Chemical Composition					Calori- metric value calories	Calori- metric value B. T. U.
			H <sub>2</sub> O.	V.C.	F.C.	A.	S.		
Opening 1 mile east Clarysville.....	Rutledge	335	1.37	18.26	64.64	15.73	0.62	....	....
"Franklin," Cumberland G.C.C.Co., Franklin	Rutledge	337	.78	16.90	59.69	22.63	2.71	....	....
"Franklin," Cumberland G.C.C.Co., Franklin	Dunn	337	.54	16.70	69.40	13.36	1.48	....	....
Piedmont-Cumberland C. Co., Franklin.....	Rutledge	337	.73	15.54	72.00	11.73	1.39	....	....
(breast) .....	Dunn	337	.78	15.54	75.43	8.25	1.10	7828	14,090
(bottom) .....	Dunn	337	.79	15.84	70.88	12.49	2.61	7463	13,433
"Tacoma," Piedmont & G.C.C.Co., Franklin	Rutledge	338	.65	17.31	68.82	13.22	1.37	....	....
(breast) .....	Dunn	338	.55	14.97	74.53	9.05	1.47	7536	13,305
(bottom) .....	Dunn	338	.57	19.73	69.99	9.71	2.49	....	....
Opening, J. O. J. Green, Westernport.....	Rutledge	339	1.60	17.55	71.53	9.32	1.28	....	....
(breast) .....	Rowe	339	.49	16.44	76.61	6.40	1.21	8109	14,590
(bottom) .....	Rowe	339	.46	16.55	73.30	9.69	0.88	7732	13,917
"Buxton," Davis C. & C. Co., Piedmont.....	Dunn	340	.59	15.80	75.85	7.76	1.22	7828	14,090
(top) .....	Rowe	340	.59	16.56	71.52	11.33	1.20	7625	13,725
(middle) .....	Rowe	340	.44	17.08	76.59	6.89	2.26	8061	14,510
(bottom) .....	Rowe	340	.42	18.89	65.65	15.04	1.03	7276	13,097
(floor) .....	.....	340	.56	15.50	70.92	12.93	1.12	7702	13,863
Average composition .....			.70	16.78	71.03	11.49	1.55	....	....
Av. of those determined calorimetrically.....			.57	16.58	72.14	10.71	1.33	7677	13,819

*Lower Freeport Coal.*

Opening, old Gorman Plane, Franklin.....	Rutledge	341	0.67	18.58	67.18	13.57	5.26	....	....
--	----------	-----	------	-------	-------	-------	------	------	------

*Upper Freeport Coals.*

"Brant," Braddock C. Co., Clarysville.....	Rutledge	342	.98	17.19	71.63	10.25	3.73	....	....
Opening, Buskirk Farm, Gilmore.....	Rutledge	343	1.49	17.71	62.59	13.21	2.36	....	....
"Morrison," Frostburg C. M. Co., Morrison..	Rutledge	343	.82	16.50	74.59	8.00	1.84	....	....
"Morrison," Frostburg C. M. Co., Morrison..	Dunn	343	.55	15.37	74.26	9.82	1.56	7712	13,881
(top) .....	Rowe	343	.46	10.73	71.49	11.32	1.20	7605	13,689
(bottom) .....	Rowe	343	.97	17.56	71.32	10.15	1.28	7806	14,051
Opening, old Gorman Plane, Franklin.....	.....	344	.72	19.23	60.18	19.87	2.72	....	....
Average composition .....			.85	17.18	69.44	12.53	2.09	....	....
Av. of those determined calorimetrically.....			.66	16.55	72.36	10.43	1.35	7707	13,862

*Brush Creek (Masontown) Coals.*

Opening, Coleman's, Lonaconing .....	Rutledge	346	1.08	19.47	62.64	16.51	2.26	....	....
Opening, J. Mowbray, Barton .....	Rutledge	347	1.07	16.44	70.78	11.71	2.88	....	....
Opening, H. Moore, Barton .....	Rutledge	347	.67	17.61	70.44	11.28	3.57	....	....
Opening, J. O. J. Green, Phoenix .....	Rutledge	348	.70	16.74	67.67	14.89	1.69	....	....
Opening, Wm. Neff, Phoenix .....	Rutledge	349	.00	16.75	72.75	9.60	1.54	....	....
Opening, Athey's, Phoenix .....	Rutledge	349	4.42	18.56	70.74	6.28	.63	....	....
"Morrison," Frostburg C. M. Co., Morrison..	.....	349	.57	15.60	68.50	15.33	2.60	....	....
Opening, S. Franklin .....	.....	350	.55	15.80	60.77	22.88	3.08	....	....
Average composition .....			1.24	17.12	68.04	13.60	2.28	....	....

TABLE OF ANALYSES OF MARYLAND COALS.—*Continued.*  
 ANALYSES OF GEORGES CREEK COALS.—*Continued.*
*Bakerstown Coals.*

Mine	Collected by	See page	Chemical Composition					Calorimetric value calories	Calorimetric value B. T. U.
			H <sub>2</sub> O.	V.C.	F.C.	A.	S.		
Opening, Mt. Savage .....	Rutledge	350	1.00	18.66	69.20	11.14	2.59	....	....
Opening, near Clarysville .....	Rutledge	352	.88	16.55	66.60	15.97	.60	....	....
Opening, near Loarville .....	Rutledge	353	.88	18.76	65.38	14.98	.83	....	....
Opening, Md. C. Co., Koontz .....	Rutledge	353	1.10	16.32	66.17	16.41	1.81	....	....
Opening, J. Wier, Lonaconing .....	Rutledge	354	1.59	20.62	68.86	8.03	0.86	....	....
Opening, J. Wier, Lonaconing .....	Martin	355	.92	18.44	62.17	18.47	1.74	....	....
Opening, Ifansell Farm, Lonaconing .....	Rutledge	356	.90	18.60	64.16	16.34	3.73	....	....
Opening, between Pekin and Moscow .....	Rutledge	358	.60	16.56	70.28	12.56	6.62	....	....
Opening, between Pekin and Moscow .....	Rutledge	358	.98	17.54	72.06	9.42	1.97	....	....
Opening, near Moscow Mills .....	Rutledge	358	1.16	17.74	73.10	8.00	2.09	....	....
Opening, A. B. Shaw, Barton .....	Rutledge	359	1.09	18.06	70.40	10.54	2.30	....	....
Opening, A. B. Shaw, Barton .....	Rutledge	359	.82	17.33	72.00	9.85	1.55	....	....
Opening, 3 m. n. w. Barton .....	Rutledge	359	1.95	18.25	76.25	3.55	.51	....	....
"Moscow No. 2," Moscow-G. C. M. Co., Barton .....	Rutledge	360	.68	17.01	68.39	13.92	4.58	....	....
"Moscow No. 2," Moscow-G. C. M. Co., Barton .....	Dunn	360	1.16	19.19	71.72	7.98	3.38	....	....
"Swanton," Chapman M. Co., Barton .....	Rutledge	360	.93	19.28	70.24	9.55	1.99	....	....
"Swanton," Chapman M. Co., Barton .....	Dunn	360	.41	16.66	68.87	14.06	1.01	....	....
Opening, M. N. Fazanbaker, Barton .....	Rutledge	360	1.72	19.60	67.48	11.20	1.79	....	....
"Potomac," Union M. Co., Barton .....	Rutledge	361	1.00	18.51	70.28	10.21	1.78	....	....
"Potomac," Union M. Co., Barton (top).....	Rowe	361	.64	17.02	72.42	9.02	1.84	7830	14,094
"Potomac," Union M. Co., Barton (bottom).	Rowe	361	.60	17.71	72.93	8.76	.59	7938	14,288
Opening, S. Ross, Barton .....	Rutledge	361	.79	17.42	73.87	7.92	1.51	....	....
Opening, Henry Moore, Barton .....	Rutledge	362	.75	18.91	72.05	8.29	3.05	....	....
Opening, Isabel Myer, Barton .....	Rutledge	362	.97	19.09	71.75	8.19	1.41	....	....
Opening, Ezra Michael, Phoenix .....	Rutledge	363	.98	17.12	73.30	8.60	2.11	....	....
Opening, T. P. Michael, Westernport .....	Rutledge	364	1.40	17.21	76.82	4.57	1.72	....	....
Opening, Fazanbaker, Westernport .....	Rutledge	364	.70	19.93	70.74	8.63	3.02	....	....
"Eckhart," Phoenix & G. C. M. Co., Morrison	Rutledge	365	.62	16.99	74.44	7.05	1.85	....	....
"Eckhart," Phoenix & G. C. M. Co., Morrison	Dunn	365	.59	17.18	73.50	8.73	1.29	7570	13,626
Morrison, Frostburg C. M. Co., Morrison.....	Rutledge	365	.72	16.47	72.80	10.01	2.48	....	....
Morrison, Frostburg C. M. Co., Morrison.....	Dunn	365	1.29	19.41	67.76	11.54	3.04	....	....
Opening, Cumberland & G. C. C. Co., Franklin	Rutledge	366	1.05	16.78	72.11	10.06	3.13	....	....
"Penn," Cumberland & G. C. C. Co., Frank- lin .....	Dunn	366	.72	17.95	73.11	8.22	1.77	7794	14,029
Opening, Jas. Grove, Westernport .....	Rutledge	367	.88	16.89	74.89	7.34	2.48	....	....
Opening, M. Gannon, Franklin .....	Rutledge	368	1.12	16.85	71.87	10.16	1.19	....	....
Opening, Piedmont G. C. C. Co., Franklin....	Rutledge	368	3.58	18.75	70.75	6.92	.65	....	....
Average composition .....			1.03	17.98	70.80	10.19	2.08	....	....
Av. of those determined calorimetrically.....			.64	17.69	72.99	8.68	1.38	7733	14,009

*Friendsville Coals.*

N. W. Mt. Savage .....	Dunn	...	.96	18.71	70.67	9.66	2.01	7776	13,997
Opening, near Clarysville .....	Rutledge	369	.86	17.55	69.70	11.89	1.85	....	....
			1.12	19.38	71.88	7.02	3.12	....	....
Average composition .....			.98	18.84	70.75	9.73	2.32	....	....

TABLE OF ANALYSES OF MARYLAND COALS.—Continued.  
ANALYSES OF GEORGES CREEK COALS.—Continued.

*Lanaconing Coals.*

Mine	Collected by	See page	Chemical Composition					Calori- metric value calories	Calori- metric value B. T. U.
			H <sub>2</sub> O.	V.C.	F.C.	A.	S.		
Opening, New Central C. Co., Koontz .....	Rutledge	370	.75	22.42	68.19	8.64	3.31	....	....
Opening, Georges Cr. C. & I. Co., Lanaconing	Rutledge	370	.78	18.05	64.34	16.83	3.33	....	....
Outcrop, Preble's, Lanaconing .....	Rutledge	371	.84	17.09	66.88	15.19	3.16	....	....
Opening, New Central C. Co., Lanaconing....	Rutledge	371	.65	18.26	70.32	10.77	3.74	....	....
Opening, Hohing's, Lanaconing .....	Rutledge	371	.61	17.16	63.10	19.07	3.27	....	....
Average composition .....			.73	18.59	66.58	14.10	3.36	....	....

*Franklin Coals.*

Opening, Georges Cr. C. & I. Co., Lanaconing	Rutledge	373	1.77	20.16	71.00	7.07	1.11	....	....
Opening, American C. Co., Barton .....	Rutledge	374	.92	17.38	67.14	14.56	2.83	....	....
Mine, Potomac C. Co., Barton .....	Rutledge	374	.69	20.18	69.11	10.02	2.33	....	....
Opening, Old Gorman Plane, Franklin.....	Rutledge	373	1.35	18.08	67.40	13.17	1.23	....	....
Old Franklin Plane, Franklin.....	Rowe	375	.74	18.13	60.88	20.25	2.76	6944	12,499
Old Franklin Plane, Franklin.....	Rowe	375	.79	18.51	70.72	9.98	3.01	7869	14,164
Old Franklin Plane, Franklin.....	Rowe	375	.72	19.77	65.53	13.98	5.13	7382	13,188
Potomac C. Co. ....	Dunn	...	.52	17.83	70.96	10.69	2.02	7776	13,997
Average composition .....			.94	18.70	67.84	12.46	2.55	....	....
Av. of those determined calorimetrically....			.69	18.56	67.02	13.73	3.23	7493	13,487

*Little Pittsburg Coals.*

"Bonney," New Castle C. Co., Lanaconing..	Rutledge	376	1.10	19.48	68.12	11.30	1.22	....	....
Opening, American C. Co., Pekin .....	Martin	377	.82	19.94	68.90	10.34	1.51	....	....
Opening, American C. Co., Pekin .....	Dunn	377	.63	19.75	71.84	7.78	1.49	7829	14,092
Opening, E. Michael, Franklin .....	Rutledge	378	1.27	21.24	68.33	9.10	1.21	....	....
Opening, O. C. Fazenbaker, Rock Church....	Rutledge	378	5.33	22.10	63.39	9.18	.76	....	....
Average composition .....			1.83	20.50	68.12	9.55	1.24	....	....

*Pittsburg Coals.*

Geo. Cr. Bald Knob C. Co., Mt. Savage.....	Dunn	379	.57	18.37	66.74	14.32	.94	7356	13,241
"Borden," B. G. C. V. C. Co., Carlos:									
(breast) .....	Dunn	595	.57	19.04	74.61	5.78	.71	8052	14,494
(bottom) .....	Dunn	595	.54	19.16	72.17	8.13	1.17	7890	14,094
"Union No. 1," Union M. Co., Frostburg:									
(breast) .....	Dunn	382	.58	18.34	74.51	6.57	.88	8002	14,404
(breast) .....	Reese	382	.70	17.94	74.11	7.19	.94	8008	14,405
(bottom) .....	Dunn	382	.73	18.44	70.22	10.61	1.83	7604	13,987
(bottom) .....	Reese	382	.99	17.82	71.63	9.56	2.05	7754	13,957
(bottom) .....	Reese	382	1.03	18.65	72.20	8.12	1.19	7709	13,876
"Washington," Piedmont & G. C. C. Co., Eckhart (breast) .....	Dunn	598	.69	18.12	73.48	7.71	1.69	....	....
(bottom) .....	Dunn	598	.71	17.60	75.96	5.83	.94	7969	14,342
"Hoffman," Consol. C. Co., Hoffman (breast)	Dunn	564	.73	17.75	74.07	7.45	.80	7836	14,105
"Pumping Shaft," Consol. C. Co., Borden:									
(breast) .....	Reese	572	.67	17.66	74.37	7.30	.87	7984	14,371
(ply) .....	Reese	572	.59	18.91	72.66	7.84	1.49	7977	14,359
(bottom) .....	Reese	572	1.24	18.10	71.01	9.65	1.20	7730	13,925



TABLE OF ANALYSES OF MARYLAND COALS.—Continued.  
 ANALYSES OF GEORGES CREEK COALS.—Continued.  
 Pittsburg Coals.—Continued.

Mine	Collected by	See page	Chemical Composition					Calorimetric value calories	Calorimetric value B. T. U.
			H <sub>2</sub> O.	V.C.	F.C.	A.	S.		
"Carlos No. 1," Barton & G. C. C. Co.,									
Carlos (breast) .....	Dunn	387	.73	18.83	74.96	5.48	.88	8057	14,503
Carlos (bottom) .....	Dunn	387	.72	19.00	71.49	8.79	1.07	7829	14,092
"Ocean No. 7," Consol. C. Co.:									
(breast) .....	Dunn	565	.64	19.23	72.26	7.87	.83	7732	13,917
(breast) .....	Reese	565	.28	19.52	73.41	6.79	.77	8046	14,483
(bottom) .....	Dunn	565	.96	19.19	71.92	8.23	1.07	7826	14,084
(bottom) .....	Reese	565	.81	19.57	70.73	8.89	1.26	7856	14,140
"Ocean No. 1," Consol. C. Co.:									
(breast) .....	Dunn	561	.67	18.10	72.41	8.73	.66	7788	14,018
(breast) .....	Reese	561	.73	20.38	72.83	6.06	.79	8142	14,056
(bottom) .....	Dunn	561	.72	18.64	70.42	10.22	1.71	7588	13,658
(bottom) .....	Reese	561	.81	19.90	70.98	8.36	1.38	7942	14,296
"Enterprise," Midland M. Co., Midland:									
(breast) .....	Dunn	598	.65	17.89	75.28	6.18	.60	8042	14,475
(bottom) .....	Dunn	598	.83	17.80	71.55	9.82	1.45	7599	13,078
Columbia No. 9, G. C. C. & I. Co., Lonaconing:									
(breast) .....	Dunn	580	.63	18.20	75.03	6.14	.66	7909	14,236
(bottom) .....	Dunn	580	.74	18.90	74.22	6.14	.66	7835	14,103
"Ocean No. 8," Consol. C. Co., Midland:									
(breast) .....	Dunn	571	.53	18.39	75.68	5.40	.78	8085	14,553
(bottom) .....	Dunn	571	.71	19.11	72.70	7.48	.82	7780	14,004
"Ocean No. 8," Consol. C. Co., Midland:									
(breast) .....	Dunn	570	.58	19.16	74.55	5.71	.79	8124	14,623
(bottom) .....	Dunn	570	.59	18.57	74.85	6.49	.78	7977	14,349
"Koontz," New Central C. Co., Koontz:									
(breast) .....	Dunn	591	.69	20.16	71.59	7.56	.55	7983	14,369
"No. 1," G. C. C. & I. Co., Lonaconing:									
(breast) .....	Dunn	577	.63	18.58	74.86	5.93	.74	8058	14,504
(breast) .....	Dunn	577	.69	18.44	68.99	11.88	1.03	.....	.....
(bottom) .....	Dunn	577	.74	19.37	72.11	7.78	1.83	7811	14,059
"Appleton," Md. C. Co., Lonaconing (breast)	Dunn	587	.45	19.77	74.76	5.02	.55	8123	14,621
"Pine Hill," G. C. C. & I. Co., Lonaconing:									
(breast) .....	Dunn	582	.51	19.28	73.99	6.22	.81	8048	14,486
(breast) .....	Dunn	582	.53	19.76	71.85	7.86	1.06	.....	.....
(bottom) .....	Dunn	582	.74	19.48	68.25	11.53	1.46	7441	13,394
Opening, Md. C. Co., Lonaconing (breast)....	Dunn	587	.65	20.12	71.81	7.42	.82	7922	14,260
"Shamrock," Lonaconing C. Co., Lonaconing:									
(breast) .....	Dunn	608	.72	18.61	75.06	5.61	.71	8144	14,659
(bottom) .....	Dunn	608	.45	19.68	72.07	7.80	.71	7816	14,069
"Jackson No. 5," American C. Co., Lonaconing (bottom) .....	.....	589	.75	19.57	70.84	8.84	1.18	7667	13,801
"Moscow," Piedmont M. Co., Barton (breast)	Dunn	603	.79	18.41	74.20	6.60	.72	7946	14,303
"Caledonia," American C. Co., Barton:									
(breast) .....	.....	590	.52	18.52	74.57	6.39	.64	8079	14,542
(bottom) .....	Dunn	590	.89	18.02	72.82	8.27	1.40	7775	13,995
"Excelsior," M. P. Gannon:									
(breast) .....	Dunn	396	.74	19.83	73.56	5.87	.55	8070	14,520
(bottom) .....	.....	396	.71	18.39	75.70	5.20	.68	8072	14,530
"Scrap No. 1," Davis C. & C. Co., Franklin:									
(breast) .....	Dunn	613	.67	18.89	71.94	8.50	2.29	7875	14,175
(bottom) .....	Dunn	613	.56	18.99	74.77	5.68	.64	8091	14,564

TABLE OF ANALYSES OF MARYLAND COALS.—Continued.  
ANALYSES OF GEORGES CREEK COALS.—Continued.

Pittsburg Coals.—Continued.

Mine	Collected by	See page	Chemical Composition					Calorimetric value calories	Calorimetric value B. T. U.
			H <sub>2</sub> O.	V.C.	F.C.	A.	S.		
Mt. Savage:									
(breast) .....	Dunn	...	.01	18.07	75.35	5.97	.76	7960	14,339
(bottom) .....	.....	...	.67	18.77	75.65	4.91	.75	8051	14,492
Average composition .....			.70	18.81	72.96	7.26	1.01	.....	.....
Av. of those determined calorimetrically.....			.68	18.81	72.97	7.24	1.01	7902	14,218

Lower Sewickley Coals.

Opening, Md. C. Co., Lonaconing.....	Rutledge	399	.79	19.98	67.74	11.49	2.22	.....	.....
Pumping Shaft, Consol. C. Co. ....	Reese	572	.98	18.61	74.68	5.78	1.18	8029	14,452
Average composition .....			.86	19.29	71.22	8.63	1.70	.....	.....

Upper Sewickley Coals.

Opening, Piedmont & G. C. C. Co., Eckhart.	Rutledge	400	.83	18.18	71.90	9.09	1.84	.....	.....
Opening, New Central C. Co., Koontz .....	Rutledge	401	1.28	20.06	72.89	5.77	1.10	.....	.....
Opening, New Central C. Co., Koontz .....	Dunn	401	.81	20.06	73.55	5.58	.92	8015	14,427
Opening, Md. C. Co., Lonaconing .....	Rutledge	401	2.09	22.21	64.57	11.13	1.05	.....	.....
Opening, Md. C. Co., Lonaconing .....	Rutledge	401	1.10	19.26	70.95	8.69	1.42	.....	.....
Opening, Md. C. Co., Lonaconing .....	Dunn	401	.65	21.20	69.49	8.60	1.44	7708	13,874
Opening, G. C. C. & I. Co., Lonaconing .....	Dunn	402	.81	20.18	70.24	8.77	1.23	7783	14,009
Opening, G. C. C. & I. Co., Lonaconing .....	Rutledge	402	.70	21.22	70.50	7.58	1.19	.....	.....
Opening, G. C. C. & I. Co., Lonaconing .....	.....	402	.83	20.05	73.59	5.58	1.01	.....	.....
Opening, Md. C. Co., Lonaconing .....	Dunn	402	.66	19.75	70.05	9.54	1.10	7688	13,838
Opening, Md. C. Co., Lonaconing .....	Rutledge	402	.83	20.93	71.02	7.32	1.65	.....	.....
"Caledonia," Amer. C. Co., Barton.....	Rutledge	403	.59	19.59	65.87	13.95	1.49	.....	.....
(breast) .....	Dunn	403	1.18	20.26	69.55	9.01	1.95	7596	13,672
(bottom) .....	.....	403	.48	19.22	69.97	10.33	1.09	7679	13,822
Davis C. & C. Co., Franklin:									
(top) .....	Rowe	404	.47	20.20	67.46	11.87	1.22	7585	13,658
(breast) .....	Rowe	404	.31	21.50	71.91	6.28	1.13	8164	14,695
(ply) .....	Rowe	404	.99	19.61	71.04	8.36	1.64	7983	13,909
(bottom) .....	Rowe	404	.38	20.50	67.11	12.01	2.26	7636	13,745
Average composition .....			.83	20.22	70.09	8.86	1.40	.....	.....
Av. of those determined calorimetrically.....			.67	20.25	70.04	9.04	1.40	7784	14,011

Uniontown Coal.

Opening, Amer. C. Co., Lonaconing .....	Rutledge	589	.65	18.76	63.77	16.82	4.98	.....	.....
---	----------	-----	-----	-------	-------	-------	------	-------	-------

Waynesburg Coals.

"Koontz," New Central C. Co., Koontz.....	Dunn	405	.92	21.15	70.08	7.85	1.57	7709	13,876
"Koontz," New Central C. Co., Koontz.....	Rutledge	405	1.65	19.30	67.36	11.69	1.65	.....	.....
Opening, G. C. C. & I. Co., Lonaconing.....	.....	577	.64	19.67	69.46	10.23	1.83	.....	.....
Opening, Amer. C. Co., Lonaconing .....	Rutledge	589	1.09	19.92	69.94	9.05	2.28	.....	.....
Opening, Amer. C. Co., Lonaconing .....	Dunn	589	.82	19.82	71.71	7.65	.92	7784	14,011
Pumping Shaft, Consol. C. Co. ....	Reese	572	2.21	19.53	68.25	10.01	0.80	7415	13,347
Average composition .....			1.22	19.89	69.47	9.42	1.51	.....	.....
Av. of those determined calorimetrically.....			1.32	20.16	70.01	8.51	1.09	7636	13,745

TABLE OF ANALYSES OF MARYLAND COALS.—Continued.  
ANALYSES OF POTOMAC BASIN COALS.*Lower Kittanning Coals.*

Mine	Collected by	See page	Chemical Composition					Calorimetric value calories	Calorimetric value B. T. U.
			H <sub>2</sub> O.	V C.	F. C.	A.	S.		
Opening near Windom .....	Martin	413	1.40	17.58	70.79	10.23	1.55	7532	13,557
"Barnum" Monroe C. M. Co., Barnum.....	.....	415	.52	14.76	74.03	10.69	1.17	7788	14,018
"Barnum" Monroe C. M. Co., Barnum.....	.....	415	.67	15.39	72.42	11.52	1.06	7691	13,844
(top) .....	Martin	418	1.24	16.96	72.44	9.36	1.06	7692	13,846
(top) .....	Martin	415	1.02	17.08	65.37	16.53	5.07	.....	.....
(bottom) .....	Martin	415	1.11	15.76	69.50	13.63	2.91	7241	13,034
Fahey's Mine, Blaine:									
(top) .....	Martin	419	3.61	17.86	69.52	9.01	.79	7438	13,388
(bottom) .....	Martin	419	3.32	22.43	63.18	11.07	.49	7280	13,104
Opening, Cosner, Wilson:									
(top) .....	Martin	424	2.13	22.75	62.56	12.56	4.35	.....	.....
(bottom) .....	.....	424	1.04	19.52	64.20	15.24	3.82	7132	12,838
Opening, Arnold, Dobbin:									
(top) .....	.....	425	2.46	25.35	64.76	7.43	1.53	7634	13,381
(bottom) .....	.....	425	1.26	24.01	60.51	14.22	2.02	7260	13,068
Average composition .....			1.65	19.12	67.44	11.79	2.15	.....	.....
Av. of those determined calorimetrically.....			1.66	18.96	68.14	11.24	1.64	7474	13,453

*Upper Kittanning Coals.*

Tasker's, near Swanton .....	Martin	430	.49	17.05	69.85	12.61	2.75	7625	13,725
Tasker's, near Swanton .....	Martin	430	.72	19.46	66.57	13.23	3.99	7399	13,318
Average composition .....			.60	18.27	68.21	12.92	3.37	7512	13,522

*Upper Freeport Coals.*

Tasker's, near Chaffee .....	Martin	431	1.02	17.07	77.04	4.87	.83	8149	14,668
Harvey's, near Gorman .....	Martin	435	.92	20.24	68.99	9.85	1.36	7652	13,774
Davis C. & C. Co., Thomas .....	Rowe	437	.71	17.61	75.70	5.98	.71	8168	14,702
Average composition .....			.88	18.31	73.91	6.90	.96	7990	14,382

*Brush Creek Coals.*

Tasker's, near Chaffee .....	Martin	439	.78	17.58	53.04	28.60	6.71	5947	10,705
------------------------------	--------	-----	-----	-------	-------	-------	------	------	--------

*Bakerstown Coals.*

G. C. Pattison, Bloomington .....	Martin	440	.82	17.38	70.33	11.47	2.56	.....	.....
Geo. W. Tichinel, near Chaffee .....	Martin	441	.91	18.18	72.57	8.34	3.05	7821	14,078
"Barnum" Monroe C. M. Co., Barnum.....	Martin	442	.29	16.93	73.07	9.71	1.14	7867	14,161
"Barnum" Monroe C. M. Co., Barnum.....	.....	442	.82	19.02	69.73	10.43	1.11	7742	13,935
"Sharpless," near Swanton .....	.....	442	.96	18.16	71.71	9.17	1.27	7784	14,011
"Sharpless," near Swanton .....	.....	442	.51	18.26	72.64	8.59	1.28	7871	14,168
"Tasker's," near Chaffee .....	Martin	443	1.77	18.96	70.55	8.72	3.01	7655	13,779
"Beckman's," near Blaine .....	Martin	444	1.11	17.30	72.83	8.76	.72	7737	13,026
Average composition .....			.90	18.02	71.68	9.40	1.77	.....	.....
Av. of those determined calorimetrically.....			.91	18.11	71.87	9.11	1.65	7782	14,008

*Friendsville Coal.*

"Harvey's," near Kelso Gap .....	Martin	449	.97	23.27	59.76	16.00	4.51	6943	12,497
----------------------------------	--------	-----	-----	-------	-------	-------	------	------	--------

TABLE OF ANALYSES OF MARYLAND COALS.—Continued.  
ANALYSES OF POTOMAC BASIN COALS.—Continued.

*Pittsburg Coals.*

Mine	Collected by	See page	Chemical Composition					Calori- metric value calories	Calori- metric value B. T. U.
			H <sub>2</sub> O.	V.C.	F.C.	A.	S.		
Opening, near Shaw .....	Martin	450	1.21	19.98	74.28	4.53	1.11	8145	14,061
Opening, near Shaw:									
(top) .....	Rowe	449	.89	17.89	75.30	5.92	1.12	8121	14,618
(middle) .....	Rowe	449	.59	18.29	75.50	5.62	1.41	8169	14,704
(bottom) .....	Rowe	449	.59	17.60	76.35	5.46	1.38	8166	14,699
Average composition .....			.82	18.44	75.36	5.38	1.25	8150	14,670

ANALYSES OF CASTLEMAN BASIN COALS.

*Clarion (?) Coal.*

Opening, Legeer, Bittinger .....	Martin	456	.61	26.94	57.24	14.91	4.69	7093	12,767
----------------------------------	--------	-----	-----	-------	-------	-------	------	------	--------

*Lower Freeport Coals.*

Opening, Trickey, near Bittinger .....	Martin	460	.63	24.08	67.03	8.26	0.91	7800	14,040
Opening, Breneman, near Bittinger .....	Martin	460	.78	24.02	66.50	8.70	1.96	7718	13,892
Average composition .....			.70	24.05	66.77	8.48	1.43	7759	13,966

*Grantsville Coal.*

Opening, Mogart, near Jennings Mills.....	Martin	...	2.23	21.21	63.78	12.78	2.55	7195	12,951
---	--------	-----	------	-------	-------	-------	------	------	--------

*Bakerstown Coals.*

"Durst," near Jennings Mills .....	Martin	471	1.96	21.31	63.67	13.06	4.40	7350	13,230
Opening, Mogart, near Jennings Mills .....	Martin	472	1.16	21.36	68.60	8.88	2.39	7780	14,004
Breneman & Stark, near Bittinger .....	Martin	473	3.63	23.52	63.26	9.59	1.48	7500	13,500
Joel Breneman, near Bittinger .....	Martin	473	2.01	22.40	68.72	6.87	1.37	7857	14,142
F. N. Bittinger, near Bittinger .....	Martin	474	1.64	21.25	71.49	5.62	1.62	8043	14,477
Average composition .....			2.08	21.97	67.15	8.80	2.27	7706	13,871

*Maynadter Coal.*

L. Youmer, near Jennings Mills .....	.....	475	.73	21.04	60.76	17.57	2.29	6900	12,420
--------------------------------------	-------	-----	-----	-------	-------	-------	------	------	--------

ANALYSES OF UPPER YOUGHIOGHENY COALS.

*Lower Kittanning Coals.*

Oakland C. & C. Co., Corinth .....	Martin	483	1.21	23.56	68.02	7.21	2.81	7769	13,984
Offut, near Crellin .....	Martin	484	1.11	22.70	64.04	12.15	4.71	7323	13,151
Guthrie, near Crellin .....	Martin	486	.76	24.89	64.05	10.30	1.29	7632	13,738
Ashby, near Crellin:									
(top) .....	Martin	487	1.12	23.13	64.94	10.81	1.44	7420	13,356
(bottom) .....	Martin	487	1.24	21.18	59.30	18.28	1.52	6746	12,143
Preston C. & L. Co., near Crellin .....	Martin	488	1.86	22.81	62.74	12.59	.89	7293	13,127
Average composition .....			1.22	23.04	63.85	11.89	2.11	7304	13,255

TABLE OF ANALYSES OF MARYLAND COALS.—*Continued.*  
ANALYSES OF UPPER YOUGHIOGHENY COALS.—*Continued.*

*Lower Freeport Coals.*

Mine	Collected by	See page	Chemical Composition					Calori- metric value calories	Calori- metric value B. T. U.
			H <sub>2</sub> O.	V.C.	F.C.	A.	S.		
Courrell, near Crellin .....	Martin	490	1.29	23.72	54.22	20.77	2.96	6460	11,628
Opening, Michler Line .....	Martin	490	10.64	21.80	45.94	21.62	.47	5505	9,909
Average composition .....			5.97	22.76	50.08	21.19	1.71	5982	10,767

*Upper Freeport Coal.*

Nethken, near Oakland .....	Martin	492	1.46	20.98	66.99	10.57	3.53	7594	13,669
-----------------------------	--------	-----	------	-------	-------	-------	------	------	--------

*Bakerstown Coal.*

Kimmel, near Swallow Falls .....	.....	495	.80	30.81	58.22	10.17	3.18	7748	13,946
----------------------------------	-------	-----	-----	-------	-------	-------	------	------	--------

## ANALYSES OF LOWER YOUGHIOGHENY COALS.

*Lower Kittanning Coals.*

Opening, near King .....	Martin	497	1.76	22.81	62.77	12.60	1.89	7442	13,390
Isaac Meyer, Friendsville (top) .....	Martin	499	4.47	22.74	53.72	19.07	3.27	6690	12,042
Isaac Meyer, Friendsville (bottom) .....	Martin	499	1.61	23.14	55.10	20.15	3.08	6880	12,384
Browning & Custer, Friendsville .....	Martin	498	2.26	23.40	62.80	11.54	3.52	7441	13,394
O. Friend, Friendsville .....	.....	499	1.07	23.31	64.49	11.13	5.53	7752	13,953
O. Friend, Friendsville .....	Martin	499	.98	23.55	62.58	12.89	3.71	7498	13,487
White Rock, Sang Run .....	.....	500	1.44	24.28	61.81	12.47	2.38	7587	13,657
White Rock, Sang Run (top) .....	.....	500	1.75	23.16	66.47	8.02	3.54	.....	.....
Average composition .....			1.92	23.30	61.22	13.56	3.36	.....	.....
Av. of those determined calorimetrically.....			1.94	23.32	60.47	14.27	3.33	7326	13,187

*Lower Freeport Coal.*

Taylor Friend, Friendsville .....	Martin	504	2.32	23.39	56.13	18.16	6.64	6752	12,154
-----------------------------------	--------	-----	------	-------	-------	-------	------	------	--------

*Upper Freeport Coal.*

II. Frazee, near Niles Mill .....	Martin	505	1.20	26.85	62.83	9.12	1.07	7712	13,882
II. Frazee, near Niles Mill .....	Martin	505	1.13	25.43	65.66	7.78	1.15	7806	14,051
C. Friend, Friendsville .....	Martin	507	4.58	24.22	64.59	6.61	.96	7442	13,395
Average composition .....			2.30	25.50	62.36	7.84	1.06	7058	13,775

*Mahoning Coals.*

II. Frazee, Solbysport .....	Martin	508	1.21	22.58	65.68	10.53	4.64	7631	13,736
Cobert, near Friendsville .....	Martin	509	1.42	23.34	59.79	15.45	3.37	7085	12,753
Average composition .....			1.31	22.96	62.74	12.99	4.00	7358	13,214

## INDEX

### A

Aaron Run, section of Bakerstown coal on, 364.  
Accident, horizontal intensity at, 87.  
magnetic inclination at, 77.  
magnetic station at, 45.  
anticline, 269.  
Accomac, Va., magnetic station at, 61.  
Administration of road funds, 148.  
Age of coal, geological, 227.  
Air compressors for haulage of coal, 543.  
Aiderson, W. Va., magnetic station at, 63.  
Alice No. 1, mine at Stoyer, 610.  
Allegheny coals, discussed, 326.  
of Castleman Basin, 453.  
of Georges Creek Basin, 326.  
of Lower Youghiogheny Basin, 496.  
of Potomac Basin, 409.  
of Upper Youghiogheny Basin, 479.  
Allegheny county, road expenditures in, 155.  
road improvement in, 162.  
Allegheny-Garrett boundary survey, 101-141.  
Allegheny epoch, 281.  
Allegheny formations, 243, 319.  
columnar sections of, 297.  
composition and relations of, 297.  
discussed, 246.  
sections in, 248, 250.  
Allegheny Mining Co., 517, 521.  
Ames coal, 252.  
Ames limestone, 307.  
American Coal Co., 251, 521, 559, 589.  
section of Franklin coal on property of, 374.  
Little Pittsburg coal on property of, 377.  
Pittsburg coal on property of, 391, 393.  
Upper Sewickley coal on property of, 402, 403.  
Waynesburg coal in mine of, 405, 406.  
Analyses of coal, 620.  
proximate, 621.  
table of, 628.  
ultimate, 622.

Anderson, Jake, section of Upper Freeport coal on property of, 436.  
Annapolis, horizontal intensity at, 85.  
magnetic inclination at, 75.  
magnetic station at, 45, 46.  
Anne Arundel county, road expenditures in, 155.  
Anthracite coal in Maryland, 318.  
Anticlines and synclines of coal district, map showing, 260.  
Anticline at Deer Park, 265.  
Appalachian coal field discussed, 232.  
development of, 223.  
Appleton mine, 586.  
Arnold, Washington, section of Lower Kittanning coal in mine of, 425.  
Arnold's Run, section of Lower Kittanning on, 486, 488.  
Ash, definition of, 621.  
determination of, 622.  
examination of, 625.  
Ashby, C. A., 104.  
Ashby's mine, section of Lower Kittanning coal in, 487.  
Asher glade, section of Upper Freeport coal near, 506, 507.  
Aspinwall, Wm. H., 519.  
Athey farm, section of Brush Creek coal on, 349.  
Atkinson, Gordon T., v.  
Atlantic and Georges Creek Coal Co., 521.  
Azimuth of observations, 139.

### B

Backbone Mountain, horizontal intensity at, 86.  
magnetic inclination at, 76.  
magnetic station at, 60.  
Bakerstown coal, 252, 304, 305, 319, 320, 322.  
discussed, 350, 440, 468, 494, 510.  
sections of, 350-368, 440-448, 469-474, 495, 510.  
Baltimore, horizontal intensity at, 85.  
magnetic inclination at, 75.  
magnetic station at, 46.  
Baltimore county, road expenditures in, 155.  
road improvement in, 165.

- Barnum,  
 section of Bakerstown coal near, 442.  
 Lower Freeport coal near, 431.  
 Lower Kittanning coal near, 415.  
 Barnum mine, 607.  
 sections of Lower Kittanning coal in,  
 415.
- Barrellville,  
 sections of Bakerstown coal near, 351.  
 Brookville coal near, 328, 329.  
 Brush Creek coal near, 346.  
 Clarion coal near, 332.  
 Lower Freeport coal near, 340.
- Bartlett Run, section of Bakerstown  
 coal on, 357.
- Barton coal, 305, 319, 320.  
 discussed, 350, 440.
- Barton Coal Co., 521.
- Barton Mining Company, section of  
 Upper Sewickley coal on property  
 of, 408.
- Barton,  
 sections of Bakerstown coal near, 356,  
 357, 359, 360, 361, 362, 363.  
 Brush Creek coal near, 347.  
 Conemaugh formation at, 251.  
 Franklin coal near, 374.  
 Little Pittsburg coal near, 378.  
 Mahoning Coal near, 345.  
 Pittsburg Coal near, 393, 394.  
 Upper Sewickley coal near, 403.
- Barton and Georges Creek Valley Coal  
 Co., 573, 575.  
 section of Pittsburg coal at mine of,  
 386, 387.
- Bauer, L. A., 25, 101.
- Bayard,  
 section of Allegheny formation at,  
 249.  
 Bakerstown coal near, 447.
- Bay Ridge, magnetic inclination at, 76.  
 magnetic station at, 46.
- "Beachy" coal, 304.
- Beachey's, Aaron, section of Grantsville  
 coal in mine of, 465.
- Beachwood, section of Lower Kittanning  
 coal near, 426.
- Beall, L. L., 104.
- Beaman sawmill, section of Bakerstown  
 coal near, 353.
- Bear Creek Lumber Co., section of  
 Lower Kittanning coal on prop-  
 erty of, 498.
- Beckman, Rudolph, section of Bakers-  
 town coal on property of, 444.
- Bedford road, improvement of, 164.
- Belzel, Henry, section of Friendsville  
 coal in mine of, 476.
- Belair, horizontal intensity at, 85.  
 magnetic inclination at, 75.  
 magnetic station at, 46.
- Belair-Churchville road, improvements  
 to, 173.
- Belcamp, horizontal intensity at, 85.  
 magnetic inclination at, 75.  
 magnetic station at, 46.
- Bender, Joel, sections of Lower Kittan-  
 ning coal in opening of, 458.
- Bender coal discussed, 456.
- Benwood limestone, 311.
- Berlin, horizontal intensity at, 85.  
 magnetic inclination at, 75.  
 magnetic station at, 46.
- Better roads, movement toward, 146.
- Betterton, horizontal intensity at, 87.  
 magnetic inclination at, 77.  
 magnetic station at, 47.
- Bevan, Creg, section of Bakerstown coal  
 in mine of, 470.
- Bevansville,  
 section of Friendsville coal near, 476.  
 Grantsville coal near, 466, 467.
- Beverly, W. Va., magnetic station at, 63.
- Big Savage fire-clay tunnel,  
 section of Allegheny formation in,  
 250.  
 Pottsville formation in, 245.
- Big Shade Run,  
 section of Friendsville coal on, 476.  
 Grantsville coal on, 464.
- "Big Vein" coal, 310, 322, 529.  
 discussed, 380.  
 irregularities of, 557.  
 thickness of, 531.  
 working of, 532.
- Big Vein Hill, section of Lonaconing coal  
 on, 371.
- Bittinger,  
 sections of Bakerstown coal near, 472-  
 474.  
 Clarion coal at, 456.  
 Friendsville coal near, 476.  
 Grantsville coal near, 468.  
 Lower Freeport coal near, 460.  
 Mahoning coal near, 462.
- Bittinger, F. N., section of Bakerstown  
 coal in mine of, 474.
- Bittinger, Jake, section of Grantsville  
 coal in mine of, 468.
- Black Bear mine, section of Clarion coal  
 near, 412.
- Black, Sheridan and Wilson Co., 573.
- Blackston, G. P., 104.
- Blaen Avon Coal Co., 521.
- Blaine,  
 sections of Bakerstown coal near, 444.  
 Brush Creek coal near, 440.  
 Clarion coal near, 412.  
 Conemaugh formation near, 252.  
 Upper Freeport coal near, 432-434.  
 Lower Kittanning coal near, 417-  
 419.

- Blaine,  
Pottsville formation at, 247.
- Blaine Mining Co., 611.  
section of Lower Kittanning coal on property of, 418.
- Block coal, 240.
- Bloomington,  
section of Bakerstown coal near, 440.  
Lower Kittanning coal near, 338.
- Bloomington coal, 319, 320, 324.
- Bluebaugh coal discussed, 319, 320, 328, 409, 455.
- Bolden, C., 126.
- Bole, Johnny, section of Lower Kittanning coal in mine of, 481.
- Bolivar fire-clay, 300.
- Bombay Hook, Del., magnetic station at, 61.
- Bonic, Henry, section of Grantsville coal in mine of, 464.
- Bonney mine, section of Little Pittsburg coal in, 376.
- Borden mine, 595.
- Borden Mining Co., 518, 521, 595.  
section of Pittsburg coal on property of, 385.
- Borden shaft, section of Monongahela formation at, 255.
- Boundary line, length of, 140.  
manner of marking, 128.
- Bowery mine, section of Pittsburg coal in, 385.
- Bracket, F. E., 135.
- Braddock Coal Co., 595.  
section of Upper Freeport coal on property of, 342.
- Braddock Run, section of Upper Freeport coal on, 342.
- Bradshaw, horizontal intensity at, 86.  
magnetic inclination at, 76.  
magnetic station at, 47.
- Braller, David, 594.
- Brandywine, magnetic inclination at, 75.  
magnetic station at, 47.
- Brant mine, section of Upper Freeport in, 342.
- Brant Run, section of Lower Kittanning coal near, 336.  
section of Upper Freeport coal near, 342.
- "Break-throughs" in coal mines, 534.
- Breneman and Stark's mine, section of Bakerstown coal in, 473.
- Breneman, John, section of Lower Freeport coal on property of, 460.
- Brew, George, section of Bakerstown coal in mine of, 472.
- Brookville coal discussed, 247, 298, 319, 320, 328, 409, 455.  
sections of, 328-331, 454.  
sections near Barrellville, 328.
- Brown, E. Ward, 171.
- Brown, W. McCulloh, 104.
- Browne, A. L., 219.
- Browning and Custer mine, section of Lower Kittanning coal in, 498.
- Brush Creek coal, 252, 303.  
discussed, 346, 439, 463, 509.  
sections of, 345-350, 439-440, 463, 509.
- Buckhannon, W. Va., magnetic station at, 63.
- Buffalo Run,  
section of Lower Freeport coal on, 504.  
Lower Kittanning coal on, 499.
- Buffalo sandstone, 252, 304.
- Burrell, J. L. A., 104.
- Buskirk farm,  
section of Lower Kittanning coal on, 336.  
Upper Freeport coal on, 343.
- Butler, Hampton, section of Bakerstown coal in mine of, 472.
- Buxton mine, 615.  
section of Lower Kittanning coal in, 340.

## C

- Caledonia mines, 590.
- Caledonia mine,  
section of Pittsburg coal at, 393.  
Upper Sewickley coal in, 403.
- Caloric or heating values, 622.  
tables of, 628.
- Calorimeter, description of, 623.
- Calorimetric tests, 622.
- Calvert, horizontal intensity at, 87.  
magnetic inclination at, 77.  
magnetic station at, 47.
- Calvert county, road expenditures in, 155.
- Cambridge, horizontal intensity at, 86.  
magnetic inclination at, 76.  
magnetic station at, 47.
- Camp Fairfax, horizontal intensity at, 86.  
magnetic station at, 60.
- Camp Potomac, magnetic station at, 60.
- Campbell, M. R., 303.
- Cannel coal, 240.
- Carbonaceous shales, 318.
- Carboniferous or Mississippian period, 275.
- Carboniferous strata of Nova Scotia, 226.



- Cardiff, horizontal intensity at, 86.  
magnetic inclination at, 75, 76.  
magnetic station at, 47.
- Carlos, 139.
- Carlos mines, 575.
- Carlos, sections of Pittsburg coal at, 386, 387.
- Caroline county, road expenditures in, 155.
- Carroll county, road expenditures in, 155.
- Castleman Basin, 317.  
discussed, 452.  
Allegheny coals of, 453.  
Conemaugh coals of, 461.  
Pottsville coals of, 452.
- Castleman River,  
section of Bakerstown coal in R. R. cut on, 469, 470.  
Mahoning coal on, 462.  
Maynadler coal in R. R. cut on, 474.
- Castleman syncline, position of, 265.
- Castleman Valley, section of Conemaugh formation in, 253.
- Castle Run, section of Bakerstown coal on, 353.
- Cecil county, road expenditures in, 156.  
road improvements in, 170.
- Cement, tensile strength of, 195.
- Cement, tests, 194.
- Cenozoic era, 289.
- Central avenue, improvements to, 183.
- Central Coal M. & M. Co., 521.
- Centerville, horizontal intensity at, 85.  
magnetic inclination at, 75.  
magnetic station at, 48.
- Centerville-Chestertown road, improvements to, 184.
- Chaffee,  
sections of Bakerstown coal near, 441, 443.  
Brush Creek coal near, 439.  
Clarion coal near, 411.  
Lower Kittanning coal near, 417.  
Mahoning coal near, 439.  
Upper Freeport coal near, 431.
- Chapman Coal Mining Co., 599.
- Chapman opening, section of Barton coal in, 360.
- Character of coal and its uses, 238.
- Character of the rocks of the coal district, 271.
- Charles county, road expenditures in, 156.
- Charlottesville, Va., magnetic station at, 62.
- Cheltenham, magnetic station at, 48.
- Chemical and heat producing properties of Maryland Coals, 619.
- Cherrydale, Va., magnetic station at, 62.
- Chesapeake Coal Co., 518.
- Chesapeake Junction road, improvements to, 184.
- Chestertown, horizontal intensity at, 86.  
magnetic inclination at, 76.  
magnetic station at, 48.
- Chisholm's boundary line, 105, 139.
- Christiansburg, Va., magnetic station at, 62.
- Churchville, horizontal intensity at, 86.  
magnetic inclination at, 76.  
magnetic station at, 49.
- Churchville-Havre de Grace road, improvements to, 173.
- Clarion coal discussed, 298, 319, 320, 324, 331, 409, 455, 479.  
sections of, 332, 410-412, 455, 456, 479.
- Clarion sandstone, 247, 298.
- Clark, Wm. Bullock, 103, 219, 221, 291, 317.
- Clark's opening in Lower Kittanning coal, 423.
- Clarksburg, W. Va., magnetic station at, 63.
- Clarkshurg limestone, 307.
- Clarysville,  
section of Bakerstown coal near, 352.  
Friendsville coal near, 369.  
Lower Kittanning coal near, 335, 336.  
Upper Freeport coal near, 342.
- Cleavage planes in Georges Creek coal, 558.
- Coal 8b, 306.  
analyses of, 628.  
culling the, 539.  
distribution and production of, 228.  
from mine to tippie, method of conveying, 551.  
early use of, 222, 223.  
geological age of, 227.  
history of the use of, 222.  
its character and uses, 238.  
origin of, 224.  
prices for mining, 541.  
production in United States, 232.  
Northern Appalachian, 234-237.  
prospecting for in lower beds, 322.  
position of, 221.  
table showing world's production of, 229.
- Coal basins in Maryland, map showing 318.  
beds, distribution and character of, 317.  
general relations, 317.  
cars in mines, 555, 556.
- Coal companies consolidate, 519.

- Coal-cutting machine, 540.  
 Coal deposits, position of, 221.  
 Coal district of Maryland,  
   geology of, 241.  
   stratigraphy of, 241.  
 Coal measures, geological structure of,  
   259.  
 Coal measures of Maryland, section  
   showing, 243.  
 Coal mine, first, 513.  
 Coal mines of Maryland, 529.  
 Coal mines, drainage of, 549.  
   lighting of, 549.  
   signals in, 552.  
   ventilation in, 545.  
 Coal mining, prices paid for, 559.  
   sketch showing method of, 544.  
 Coal region history of, 513.  
 Coal samples, preparation of, 619.  
 Coal seams of commercial value, table  
   showing, 319.  
 Coal seams, generalized section showing,  
   319.  
   naming of, 321.  
   table showing correlation of, 320.  
 Coals of Maryland, report on, 219.  
 Cobert's mine, section of Mahoning coal  
   in, 509.  
 Cockeysville, horizontal intensity at, 85.  
   magnetic inclination at, 75.  
   magnetic station at, 49.  
 Coking yards, 517.  
 Columnar sections of Allegheny forma-  
   tion, 297.  
   Conemaugh formation, 302.  
   Dunkard formation, 313.  
   Monongahela formation, 309.  
   Pottsville formation, 293.  
 Compton, Ross, section of Bakerstown  
   coal in mine of, 470.  
 Concrete bars, tests on, 194.  
 Conemaugh coals discussed, 344.  
   of Castleman Basin, 461.  
   of Georges Creek Basin, 344.  
   of Lower Youghiogheny Basin, 506.  
   of Potomac Basin, 438.  
   of Upper Youghiogheny Basin, 493.  
 Conemaugh epoch, 283.  
 Conemaugh formation discussed, 243,  
   251, 319.  
   columnar sections of, 302.  
   composition and relations of, 301.  
   sections in, 251-254.  
 Connell, T. A., section of Lower Free-  
   port coal in mine of, 490.  
 Connellsville sandstone, 252, 308.  
 Consolidation of coal companies, 519.  
 Consolidation Coal Co., 514, 518, 521,  
   559.  
 Consolidation Coal Co.,  
   mines of, 561.  
   section of Pittsburg coal on property  
     of, 383, 384.  
   Uniontown coal in Pumping shaft,  
     404.  
   system of mining, 533.  
 Contents, 21.  
 Corinth, section of Lower Kittanning  
   coal near, 483.  
 Coromandel Coal Co., 606.  
 Correlation table of coal seams, 320.  
 Correlation of the formations and mem-  
   bers, 291.  
 Cornnna, horizontal intensity at, 86.  
   magnetic inclination at, 76.  
   magnetic station at, 49.  
 Cosner, W. H., opening in Lower Kittan-  
   ning coal, 424.  
 County road expenditures, 153.  
 County road law, outline of, 149.  
 Crane's mine, section of Lower Kittan-  
   ning coal in, 484.  
 Cranesville anticline, 269.  
 "Crazy Vein," section of Lower Kittan-  
   ning coal in, 497.  
 Crellin,  
   section of Clarion coal near, 479.  
   Lower Freeport coal near, 490.  
   Lower Kittanning coal near, 484-  
     489.  
 Creswell, magnetic inclination at, 75.  
   magnetic station at, 49.  
 Crinoidal coal discussed, 306, 319, 320,  
   368, 448, 475, 510.  
 Crinoidal limestone, 307.  
 Crisfield, horizontal intensity at, 86.  
   magnetic inclination at, 76.  
   magnetic station at, 49.  
 Crosby, W. W., 165.  
 Cross Roads, horizontal intensity at, 88.  
   magnetic inclination at, 78.  
   magnetic station at, 49.  
 Cross mine, section of Upper Freeport  
   coal in, 493.  
 Culling the coal, 539.  
 Culpeper, Va., magnetic station at, 62.  
 Cumberland, horizontal intensity at, 85.  
   magnetic inclination at, 75.  
   magnetic station at, 49.  
 Cumberland Basin Coal Co., 593.  
   sections of Clarion coal in mine of,  
     332.  
 Cumberland coal, 530.  
 Cumberland-Georges Creek Coal Co., 603.  
   section of Bakerstown coal on prop-  
     erty of, 366.  
   Lower Kittanning coal in mine of,  
     337.  
 Cumberland Coal and Iron Co., 518, 521.

## D

- Dagsboro, Del., magnetic station at, 61.
- Damascus, horizontal intensity at, 86.  
magnetic inclination at, 76.  
magnetic station at, 49.
- Dans Mountain, section of Brookville coal on, 331.
- Darton, N. H., 259, 261, 262.
- Datesman Coal Company, 610.
- Davis, Wm., 175, 176.
- Davis Coal and Coke Company, 414, 437, 438, 449, 614.  
section of Clarion coal on property of, 332.  
Lower Kittanning coal in mine of, 340, 426-428.  
Pittsburg coal in mine of, 397.  
Upper Sewickley coal on property of, 404.  
Upper Freeport coal in, 437, 438.
- Davis coal discussed, 248, 319, 320, 334, 413.  
section of, 427, 428.
- Davis and Ricman, 521.
- Dawson, J. W., 226.
- "Deal mine," section of Upper Freeport coal in, 494.
- Deep Creek, section of Lower Kittanning coal near, 480.
- Deer Park anticline, 265.
- Deer Creek Farmer's Club, 146.
- Delaware, magnetic stations in, 61.
- Denton, magnetic station at, 49.
- Derwood, magnetic declination at, 44.  
horizontal intensity at, 88.  
magnetic inclination at, 75.  
magnetic station at, 50.
- Detmold Hill,  
section of Bakerstown coal on, 355.  
Lonaconing coal on, 371.  
Upper Sewickley coal on, 401.
- Devecmon's mine, section of Upper Freeport coal in, 492.
- Dickerson, horizontal intensity at, 85.  
magnetic inclination at, 75.  
magnetic station at, 50.
- Dickerson road, improvements to, 179.
- Dill No. 1 mine, 614.
- "Dirty nine-foot" coal discussed, 252, 308, 371.
- Distribution of magnetic inclination or dip for January, 1900, 64.  
magnetic declination in Maryland for January 1, 1900, 28.
- Distribution and character of Maryland coal beds, 317.
- Distribution and production of coal, 228.
- Diurnal variation, horizontal intensity, 66, 67, 80.  
magnetic dip, 70.  
vertical intensity, 68, 69.
- Dobbin, section of Lower Kittanning coal near, 425.
- Dog Town, section of Bakerstown coal near, 361.
- Dorchester county, road expenditures in, 156.
- Dorrey test, 200.
- Dorsey, Albert, 178.
- Drainage of coal mines, 549.
- "Drawing pillars," 536.
- Dublin, horizontal intensity at, 86.  
magnetic inclination at, 76.  
magnetic station at, 50.
- "Dug Hill," section of Dunkard formation on, 258.
- Dunkard coals discussed, 406.  
of the Georges Creek Basin, 406.
- Dunkard epoch, 289.
- Dunkard formation, 243, 319.  
columnar sections of, 258, 313.  
composition and relations, 312.  
discussed, 258.
- Durst, J. L., section of Bakerstown coal in mine of, 471.

## E

- Eastern avenue, improvement of, 166.
- Easton, horizontal intensity at, 85.  
magnetic inclination at, 75.  
magnetic station at, 50.
- Eckhart mine, Consolidation Coal Co., 600.  
section of Pittsburg coal in, 383.  
Bakerstown coal near, 352.  
Brookville coal, 329.  
Upper Sewickley coal at, 400.
- Elkridge, M. O., 185.
- Elk garden, 252.  
section of Pittsburg coal at, 451.
- Elk garden coal discussed, 319, 320, 380.
- Elk garden formation, 309.
- Elklick coal discussed, 307, 319, 320, 369.
- Elklick Run,  
section of Lower Kittanning coal on, 416.  
Upper Freeport coal on, 343.
- Elkton, horizontal intensity at, 85.  
magnetic inclination at, 75.  
magnetic station at, 50.
- Elkton-Blue Ball road, improvement to, 172.
- Ellicott City, horizontal intensity at, 85.  
magnetic inclination at, 75.  
magnetic station at, 50.
- Empire, section of Clarion coal near, 410.
- Enterprise mine, 599.
- Equal magnetic declination, map of, 44.

Excelsior mine, No. 2, section of Pittsburg coal in, 396.  
Expenditures on roads in counties, 153-158.

## F

- Fahey's mine,  
section of Clarion coal on, 412.  
Lower Kittanning coal in, 419.  
Fairfax, Va., magnetic station at, 62.  
Fairfax Camp, magnetic inclination at, 76.  
Fairfax formation, 307.  
Fairfax meridian line, magnetic stations along, 60.  
Fairfax stone, horizontal intensity at, 86.  
magnetic station at, 60.  
magnetic inclination at, 76.  
Fair Haven, horizontal intensity at, 86.  
magnetic inclination at, 76.  
magnetic station at, 51.  
Fairweather and Ladue, opening of, 329.  
Fallston road, improvements to, 174.  
Farmington coal, 303.  
Fazembaker, M. N., section of Bakerstown coal in opening of, 360, 364.  
Fazembaker, O. C., section of Little Pittsburg coal in opening of, 378.  
Fearer, section of Lower Freeport coal near, 504.  
Ferndale mine, 603.  
Ferriferous limestone, 298.  
Field work of Highway Division, 160.  
Fike, Chris., section of Lower Freeport coal in mine of, 504.  
Fike's Hill, horizontal intensity at, 87.  
magnetic inclination at, 77.  
magnetic station at, 60, 61.  
Fire Clay Hill, 139.  
Fire-damp, 548.  
Fixed Carbon, definition of, 621.  
determination of, 628.  
Fleming, J. A., 30, 74, 77, 98.  
Fodge, Jas. W., section of Lower Kittanning coal in opening of, 481.  
Foley Mountain, horizontal intensity at, 86.  
magnetic station at, 61.  
Forest Glen, horizontal intensity at, 85.  
Forest Glen, magnetic inclination at, 76.  
magnetic station at, 51.  
Forest Hill, horizontal intensity at, 86.  
magnetic inclination at, 76.  
magnetic station at, 51.  
Forest Hill road, improvements to, 174.  
Formations and members correlated, 291.  
Fort McHenry, magnetic station at, 46.  
Fountain Green, magnetic inclination at, 75.  
magnetic station at, 51.  
"Four-foot" coal discussed, 305, 350, 440, 497, 504.  
"Fourteen-foot" coal, 310, 529.  
Franklin,  
sections of Bakerstown coal near, 366, 367, 368.  
Brush Creek coal near, 350.  
Franklin coal near, 373, 375, 376.  
Little Pittsburg coal near, 378.  
Lower Freeport coal near, 341.  
Lower Kittanning coal at, 337.  
Pittsburg coal near, 396.  
"Split-six" coal near, 333.  
Upper Freeport coal near, 344.  
Upper Sewickley coal near, 404.  
Franklin coal discussed, 252, 308, 319, 320, 371, 511.  
sections of, 372-376, 511.  
Franklin Coal Co., 521, 523.  
Franklin Hill,  
section of Pittsburg coal on, 397, 398.  
Upper Sewickley coal on, 404.  
Franklin mine, 603.  
Franklin plane,  
section of Bakerstown coal near, 367, 368.  
Franklin coal on, 375, 376.  
Frazee, Albert, section of Lower Freeport coal in mine of, 504.  
Frazee, H. M., sections of Mahoning coal in mine of, 508.  
Frazee, Hiram, section of Upper Freeport coal in mine of, 505.  
Frazee, Lucien, section of Franklin coal in mine of, 511.  
Frazee's lower seam, section of Upper Freeport coal in, 505.  
Frazee's upper seam, section of Mahoning coal in, 508.  
Frederick, horizontal intensity at, 85.  
magnetic inclination at, 75.  
magnetic station at, 51.  
Frederick county, road expenditures in, 156.  
Freeport coals, 248.  
Freight rate on coal in early days, 517.  
Frickey, Willard, section of Lower Freeport coal on property of, 460.  
Friend, Capt., section of Bakerstown coal in mine of, 510.  
Friend, C., section of Upper Freeport coal in mine of, 507.  
Friend, Oscar, section of Lower Kittanning coal in mine of, 499, 500.  
Friend, Taylor, section of Lower Freeport coal in mine of, 504.

- Friendsville,  
   section of Mahoning coal near, 509.  
   Brush Creek coal near, 509.  
   Conemaugh formation near, 254.  
   Friendsville coal near, 511.  
   Little Pittsburg coal near, 512.  
   Lower Freeport coal near, 504.  
   Lower Kittanning coal near, 497-500.  
   Upper Freeport coal near, 507.  
 Friendsville coal discussed, 252, 306, 319, 320, 368, 448, 475, 476.  
   sections of, 369, 448, 449, 476, 510, 511.  
 Frost mIne, 571.  
 Frostburg, discovery of coal at, 223.  
   Monongahela formation near, 255.  
 Frostburg, Mt. Savage coal, 327.  
   Pittsburg coal near, 382.  
   Unlontown coal at, 404.  
   Washington coal near, 407.  
 Frostburg Coal Mining Co., 517, 596.  
   section of Bakerstown coal on property of, 365.  
   Brush Creek coal on property of, 349.  
   Upper Freeport coal on property of, 343.  
 Frostburg formation, 313.  
 Frostburg Mining Co., 518.  
 Frostburg section of Lower Kittanning coal near, 334.
- G**
- Gaithersburg, horizontal intensity at, 87, 88.  
   magnetic inclination at, 77, 78.  
   magnetic disturbance at, 44.  
   magnetic station at, 51.  
 Gannon, M. P.,  
   section of Bakerstown coal in opening of, 368.  
   Pittsburg coal in opening of, 396.  
 Gannon's prospect, section of Lower Kittanning at, 337.  
 Garrett county, road expenditures in, 156.  
   road improvements in, 172.  
 Garrett County Coal and Mining Company, 611, 614.  
 Garrett property, section of Upper Freeport coal on, 493.  
 Garrison road, improvement of, 165.  
 "Gas" coal, 311, 399, 558.  
 Gases in coal mines, 548.  
 Geologic history of coal measures, 274.  
 Geological age of coal, 227.  
 Geological structure of Maryland coal measures, 259.  
 Geology of Maryland coal district, 241.  
 Georges Creek Basin discussed, 317, 321.  
   Allegheny coals of, 326.  
   Dunkard coals of, 406.  
   Monongahela coals of, 379.  
   Pottsville coals of, 323.  
 Georges Creek-Upper Potomac Basin, 529.  
 Georges Creek-Upper Potomac syncline, position of, 260.  
 Georges Creek and Bald Knob Coal Company, 504.  
 Georges Creek and Bald Knob Coal Co., section of Pittsburg coal on property of, 379.  
   Redstone coal on property of, 399.  
 Georges Creek Coal and Iron Co., 518, 521, 559, 577.  
   diagram showing system of mining, 532.  
   section of Franklin coal on property of, 373.  
   Lonaconing coal in mine of, 370.  
   Lower Kittanning coal on property of, 338.  
   Upper Sewickley coal on property of, 402.  
   track arrangement of, 574.  
 Georges Creek Mining Co., 521.  
 Georges Creek syncline described, 262.  
 Gilmore,  
   section of Lower Kittanning coal near, 336.  
   Upper Freeport coal near, 343.  
 Glse, section of Franklin coal near, 511.  
 Gorman Plane,  
   section of Bakerstown coal near, 368.  
   Franklin coal near, 373.  
   Lower Freeport coal at, 341.  
   Upper Freeport coal near, 344.  
 Gorman tippie, section of "Split-six" coal at, 333.  
 Gorman, sections of Upper Freeport coal near, 435, 436.  
 Gormanla, section of Upper Freeport coal near, 437.  
 Grafton, W. Va., magnetic station at, 63.  
 Grantsville, horizontal intensity at, 87.  
   magnetic inclination at, 77.  
   magnetic station at, 51.  
   section of Bakerstown coal near, 469.  
   Friendsville coal near, 476.  
   Grantsville coal near, 464, 465.  
   Monongahela formation near, 257.  
 Grantsville coal discussed, 304, 319, 320, 463.  
   sections of 464-468.  
 "Great" limestone, 311.

- Greenbrier epoch, 277.  
 Green Spring avenue, improvement of, 169.  
 "Green County Group," 313.  
 Green, J. O. J., fire-coal mine of, 332.  
   section of Brush Creek coal on property of, 348.  
   Clarion coal on property of, 332, 339.  
 Grove, James, section of Bakerstown coal in opening of, 367.  
 Guthrie's mine, section of Lower Kittanning coal in, 486.
- H**
- Hagerstown, horizontal intensity at, 85.  
 magnetic inclination at, 75.  
 magnetic station at, 52.  
 Hallofield road, improvements to, 175.  
 Hamil's opening in Bakerstown coal, 444.  
   Brush Creek coal, 440.  
   Lower Kittanning coal, 417.  
 Hamilton avenue, improvement of, 166.  
 Hampshire and Balto. Coal Company, 521.  
 Hampshire mine, 601.  
 Hancock, horizontal intensity at, 86.  
 magnetic inclination at, 76.  
 magnetic station at, 63.  
 Handwerk, J., section of Bakerstown coal in mine of, 471.  
 Hansell, Phillip, section of Bakerstown coal on farm of, 356.  
 Harding, H. H., 177.  
 Harford Furnace, magnetic inclination at, 75.  
 magnetic station at, 52.  
 Harford county, road expenditures in, 156.  
   road improvements in, 173.  
 Harned's boundary line, 106.  
 Harrington, Del., magnetic station at, 61.  
 Harris, J. M., 104.  
 Harrison, C. T., 163  
 Harrison, W. Va.,  
   section of Allegheny formation at, 249.  
   Clarion coal near, 412.  
   Lower Kittanning coal near, 420, 422.  
   Upper Freeport coal near, 434.  
   Upper Kittanning near, 430.  
 Harvey, Benj., section of Upper Freeport coal in mine of, 435.  
 Harvey, Jas., section of Friendsville coal in mine of, 449.  
 Harvey, N. B., section of Bakerstown coal in mine of, 445.  
 Hantage of coal, 542.  
 Havre de Grace, horizontal intensity at, 87.  
   magnetic inclination at, 77.  
   magnetic station at, 52.  
 Hendricks, W. Va., magnetic station at, 63.  
 Henry,  
   section of Allegheny formation at, 248.  
   Bakerstown coal at, 448.  
   Lower Kittanning coal at, 427.  
   Pottsville formation at, 247.  
 Herring, David, section of Friendsville coal in mine of, 511.  
 Herrington Creek, section of Lower Kittanning coal in test hole on, 482.  
 Hickory, magnetic inclination at, 76.  
 magnetic station at, 52.  
 Highland, magnetic inclination at, 76.  
 magnetic station at, 52.  
 Highland mines, horizontal intensity, 86.  
 Highway Division, form of specifications and bond used by, 203.  
 Highway operations in 1902 and 1903, 159.  
 Highway report, 145.  
 Hill Run, section of Brush Creek coal near, 346.  
 Hillen road, improvement of, 169.  
 History of Maryland coal region, 513.  
 History of the use of coal, 222.  
 Hitchins, H. & W. A., 595.  
 Hixenbaugh tract, 521.  
 Hodge, J. T., 520.  
 Hodgkins, W. C., 127.  
 Hoffman, section of Pittsburg coal at, 384.  
 Hoffman mine, 564.  
 Hohing, section of Lonaconing coal on property of, 371.  
 Homewood sandstone, 244, 247.  
 Homewood sandstone described, 206.  
 "Honeycomb" coal discussed, 304, 305, 468.  
 Hood's Mill road, improvement to, 178.  
 Horizontal intensity at various stations, 85.  
   distribution of, 78.  
   diurnal variation of, 66, 67.  
   mean diurnal variation, 80.  
   values of, 84.  
 Howard county, road expenditures in, 157.  
   road improvements in, 174.  
 Hoy tracts, 521.  
 Humbertson tract, 521.

Hunting Hill, horizontal intensity at, 88.  
 magnetic inclination at, 78.  
 magnetic station at, 52.  
 Hurlock, horizontal intensity at, 85.  
 magnetic inclination at, 75.  
 magnetic station at, 52.  
 Hyde's, horizontal intensity at, 86.  
 magnetic inclination at, 76.  
 magnetic station at, 52.

## J

Jackson mines, 589.  
 Jackson mine,  
 section of Monongahela formation near, 257.  
 Pittsburg coal at, 391.  
 Jackson Hill, section of Upper Sewickley coal on, 402.  
 Jacobs tract, 521.  
 Jennings Bros., R. R., 452.  
 Jennings Mill, 253.  
 bore-hole at, 302, 452, 461.  
 section of Allegheny formation at, 250.  
 Bakerstown coal near, 470-472.  
 Brush Creek coal at, 463.  
 Grantsville coal near, 466, 467, 468.  
 Lower Freeport coal at, 459.  
 Maynadler coal near, 475.  
 Johnson, A. N., 145.  
 Johnson (Shaw), 521.  
 Jollytown coal, 314, 319, 320.  
 limestone, 314.  
 Joppa road, improvement of, 168.

## K

Kearney, section of Bakerstown coal near, 445.  
 Kelso Gap, section of Friendsville coal near, 449.  
 Kent county, road expenditures in, 157.  
 Kent Island, horizontal intensity at, 86.  
 magnetic inclination on, 76.  
 magnetic station at, 52, 53.  
 Keyser, W. Va., magnetic station at, 63.  
 Kingsland mine, 586.  
 section of Monongahela formation above, 257.  
 Upper Sewickley coal near, 402.  
 Kinsinger's mine, section of Bakerstown coal in, 469.  
 Kite tract, 521.  
 Kittanning sandstone described, 299.  
 Kittanning seam, 248.  
 Kimmel, Chauncey, section of Bakerstown coal in mine of, 495.  
 Kitzmiller mine, section of Lower Kittanning coal in, 418.

Koontz, 521.  
 section of Bakerstown coal near, 353.  
 Lonaconing coal near, 370.  
 Monongahela formation at, 256.  
 Pittsburg coal at, 388.  
 Upper Sewickley coal near, 401.  
 Koontz coal discussed, 312, 404.  
 Koontz mine, 591.  
 Krug,  
 sections of Lower Kittanning coal near, 501, 502.  
 "Split-six" coal near, 497.

## L

Labor, history of, in coal region, 523.  
 Laboratory work of Highway Division, 187.  
 La Plata, horizontal intensity at, 85.  
 magnetic inclination at, 75.  
 magnetic station at, 53.  
 Later Carboniferous or Pennsylvania period, 278.  
 Latitudes and longitudes, 141.  
 Laugan, George, section of Bakerstown coal in opening of, 357.  
 Laurel, horizontal intensity at, 86.  
 magnetic inclination at, 76.  
 magnetic station at, 54.  
 Laurel Run,  
 section of Bakerstown coal near, 355, 358, 359.  
 Clarion coal on, 410.  
 Lower Kittanning coal on, 425, 484, 501, 502.  
 Upper Freeport coal on, 507.  
 Laws of Maryland relating to boundary line between Allegany and Garrett counties, 101.  
 Leatham, Chas., 598.  
 Leesburg, Va., magnetic station at, 62.  
 Legeer, M., section of Clarion coal on property of, 456.  
 Leonardtown, horizontal intensity at, 85.  
 magnetic inclination at, 75.  
 magnetic station at, 53.  
 Leonardtown square, improvement to, 186.  
 Lesley, J. P., 294, 310.  
 Letter of transmittal, ix.  
 Lewis, Daniel, section of Upper Freeport coal in mine of, 491.  
 Liberty, horizontal intensity at, 87.  
 magnetic inclination at, 77.  
 magnetic station at, 54.  
 Lighting of coal mines, 549.  
 Linden, horizontal intensity at, 86.  
 magnetic inclination at, 76.  
 magnetic station at, 54.



- Little Allegany,  
 section of Pittsburg coal near, 380,  
 381.  
 Upper Sewickley coal near, 400.
- Little Clarkshurg coal discussed, 308,  
 319, 320, 371, 511.
- Little Laurel Run, section of Lower  
 Freeport coal on, 459.
- Little Pittsburg coal discussed, 252, 308,  
 319, 320, 376, 511.  
 sections of, 376-378, 512.
- Lisbon, horizontal intensity at, 87.  
 magnetic inclination at, 77.  
 magnetic station at, 54.
- Loarville,  
 section of Bakerstown coal near, 353.  
 Brookville coal near, 330, 331.
- Location of first coal mine, 513.
- Lohr, Peter, section of Bakerstown coal  
 in mine of, 473.
- Lonaconing, horizontal intensity at, 87.  
 magnetic inclination at, 77.  
 magnetic station at, 54.  
 sections of Bakerstown coal near, 354,  
 355, 356.  
 Brush Creek coal near, 346.  
 Dunkard formation near, 258.  
 Franklin coal near, 373.  
 Lonaconing coal near, 370, 371.  
 Little Pittsburg coal near, 376.  
 Pittsburg coal near, 389.  
 Lower Sewickley coal at, 399.  
 Monongahela formation at, 256,  
 257.  
 Upper Freeport coal near, 343.  
 Upper Sewickley coal near, 402.  
 Waynesburg coal near, 405.
- Lonaconing coal discussed, 252, 307, 319,  
 320, 369.  
 sections of, 369-371.
- Lonaconing Coal Co., 604.
- Lostland Run, sections of Lower Kittan-  
 ning coal on, 420, 421.
- Lower Barren measures, 301, 344.
- Lower Cambridge limestone, 304.
- Lower Connoquenessing sandstone de-  
 scribed, 295.
- Lower Freeport coal discussed, 300, 319,  
 320, 340, 431, 459, 489, 503.  
 sections of 340, 341, 459, 460, 489,  
 490, 503, 504.
- Lower Freeport limestone, 300.
- Lower Freeport sandstone, 300.
- Lower Hill, horizontal intensity at, 87.  
 magnetic station at, 60.
- Lower (and Middle) Kittanning coal  
 discussed, 299, 322, 334, 413,  
 456, 497.  
 sections of, 319, 320, 334-340, 413-  
 429, 457, 458, 480-489, 497-503.
- Lower Mahoning sandstone, 301.
- Lower Mercer coal, 296, 319, 320, 325.
- Lower Pittsburg coal, 308.
- Lower red shales, 305.
- Lower Sewickley coal discussed, 256,  
 311, 319, 320, 399.  
 section of, 399.
- Lower Sharon coal, sections of, 319, 320,  
 323.
- Lower Youghiogheny Basin discussed,  
 317, 494.  
 Allegheny coals of, 496.  
 Conemaugh coals of, 506.  
 Pottsville coals of, 496.
- Lower Youghiogheny syncline, 270.
- Luke, section of Mount Savage coal  
 opposite, 327.
- Lyell, Sir Chas., 307.

## M

- Macadam materials, tests of, 187.
- Magnetic components in Maryland,  
 table showing, 91-95.
- Magnetic declinations along county  
 boundary line, 136.  
 map of equal, 44.  
 observations, 34-43.  
 observed at Linden, 1896 to 1901, 30.  
 observed at various stations in Mary-  
 land, 1896 to 1899, 31.  
 observed by Western Boundary Survey  
 in 1897, 33.
- Magnetic dip, diurnal variation of, 70.
- Magnetic elements in Maryland, table  
 showing, 91-95.
- Magnetic inclinations, Linden station,  
 74.  
 Maryland stations, 75-77.
- Magnetic observatory at Cheltenham, 28.
- Magnetic readings along county bound-  
 ary line, 134.
- Magnetic report, introduction to, 25.
- Magnetic stations along "Fairfax"  
 meridian line, 60.  
 description of, 45.  
 in Delaware, 61.  
 in Maryland, 45-64.  
 in West Virginia, 63, 64.
- Magnetic Survey of Holland compared  
 to that of Maryland, 26.
- Magnetic work done in connection with  
 county boundary line, 133.
- Mahoning coal discussed, 303, 319, 320,  
 344, 438, 462, 507, 508.  
 sections of 344, 345, 439, 462, 508,  
 509.
- Mahoning limestone, 301.
- Mahoning sandstone, 247, 251.



- Manchester, horizontal intensity at, 87.  
magnetic inclination at, 77.  
magnetic station at, 54.
- Map showing anticlines and synclines of coal district, 260.
- Martin, Geo. C., 219, 241, 291, 317.
- Maryland coal beds, distribution and character of, 317.
- Maryland Coal Co., 586.  
section of Bakerstown coal on property of, 353.  
Lower Sewickley on property of, 399.  
Pittsburg coal on property of, 389.  
Upper Sewickley coal on property of, 401, 402.
- Maryland coal district, geology of, 241.
- Maryland coal measures, section showing, 243.  
stratigraphy of, 241.
- Maryland or Savage Mt. Coal Co., 521.
- Maryland magnetic stations, 45-61.
- Maryland Mining Co., 516.
- Maryland Heights, horizontal intensity at, 86.  
magnetic inclination at, 76.  
magnetic station at, 54.
- Maryland, road expenditures in, 158.
- Mason and Dixon Line, horizontal intensity on, 87.  
magnetic inclination at, 77.  
magnetic station on, 60.
- Masontown coal discussed, 303, 319, 320, 345, 439, 463.
- Massey, horizontal intensity at, 85.  
magnetic inclination at, 75.  
magnetic station at, 55.
- Mauch Chunk epoch, 278.
- Maynadier coal discussed, 252, 306, 319, 320, 474.  
sections of, 474, 475.
- Maynadier tract,  
section of Bakerstown coal on, 472.  
Maynadier coal on, 475.
- McChesney, E. E., 181.
- McGlone mine, 593.
- McHenry, horizontal intensity at, 87.  
magnetic inclination at, 77.  
magnetic station at, 55.  
sections of Lower Kittanning coal near, 458.
- McMullen, section of Bakerstown coal near house of, 355.
- McNell's mine, section of Upper Freeport coal in, 494.
- Mechanicsville, horizontal intensity at, 85.  
magnetic inclination at, 75.  
magnetic station at, 55.
- Mercer coals, 244.
- Mesozoic era, 289.
- Method of conveying coal from mines to tipples, 551.
- Methods of observing and reducing magnetic declination, 28.
- Meyer, Isaac, section of Lower Kittanning coal in mine of, 499.
- Meyer, Isabel, section of Bakerstown coal on property of, 362.
- Meyer's house, section of Bakerstown coal near, 358.
- Michael, Ezra,  
section of Bakerstown coal near house of, 363.  
Little Pittsburg near house of, 378.
- Michaels Run, section of Bakerstown coal on, 363.
- Michael, Peter, section of Upper Freeport coal on property of, 343.
- Michael, T. P., section of Bakerstown coal near house of, 364.
- Miehler monument, 141.
- Middlebrook, horizontal intensity at, 88.  
magnetic inclination at, 78.  
magnetic station at, 55.
- Middle Kittanning coal discussed, 299, 319, 320, 334, 413, 456.
- Midland Mining Co., 599.
- Midlothian Coal and Iron Co., 521.
- Midlothian, section of Pittsburg coal at, 385.
- Mier, James, section of Bakerstown coal near house of, 354, 355.
- Mileage of Maryland roads, 153.
- Mill Run,  
section of Bakerstown coal on, 360, 362.  
Brush Creek coal on, 348, 349.  
Upper Freeport on, 343.
- Miller, John, section of Bakerstown coal in mine of, 471.
- Miller Run, section of Upper Freeport coal on, 494.
- Millstone Hollow, section of Brookville coal at, 329.
- Mine cars, 555, 556.
- Mine tracks, 544.
- Mine No. 1 of G. C. C. & I. Co., 577.
- Minefield, horizontal intensity at, 86.  
magnetic inclination at, 76.  
magnetic station at, 55.
- Mineral Spring, section of Upper Freeport coal near, 505.
- Mining, methods of, 530.
- Mississippian period, 275.
- Molsture, definition of, 621.  
determination of, 621.
- Monongahela coals discussed, 379.  
of Georges Creek Basin, 379.  
of Potomac Basin, 449.

- Monongahela epoch, 287.  
 Monongahela formation, 243, 255, 319.  
 Monongahela formation, columnar sections of, 309.  
     composition and relations of, 308.  
     sections in, 255-257.  
 "Monongahela Series," 309.  
 Monroc Coal Mining Co., 607.  
     sections of Bakerstown coal in mines of, 442.  
 Montell Tunnel, section of Brookville coal at, 330.  
 Montgomery county, road expenditures in, 157.  
     road improvements in, 179.  
 Moon Ridge, section of Upper Freeport coal at, 436.  
 Moore, Henry.  
     section of Bakerstown coal in opening of, 362.  
     Brush Creek coal near house of, 347.  
 Moore, Isabel, section of Mahoning coal on property of, 345.  
 Moores Run,  
     section of Bakerstown coal on, 361, 362.  
     Brush Creek coal on, 347.  
     Mahoning coal near, 345.  
 Mooredale mine, 603.  
 Morantown, section of Lonaconing coal near, 369.  
 Morgantown limestone, 307.  
 Morgantown sandstone, 252.  
 Morgart's tract,  
     section of Maynadier coal on, 475.  
     Bakerstown coal on, 472.  
 Morrison mine, 596.  
     section of Brush Creek coal at, 349.  
     Freeport coal at, 343.  
 Moscow, sections of Bakerstown coal near, 358.  
 Moscow-Georges Creek Mining Co., 601.  
     section of Bakerstown coal on property of, 360.  
 Moscow Mills,  
     section of Bakerstown coal near, 358.  
     Little Pittsburg near, 377.  
 Moscow mines, 602, 604.  
     Pittsburg coal near, 390, 392.  
 Mount Savage,  
     sections of Bakerstown coal near, 350, 351.  
     Brush Creek coal near, 345, 346.  
     Franklin coal near, 372.  
     Lonaconing coal near, 369, 370, 372.  
     Mahoning coal near, 344.  
     Mt. Savage coal near, 326.  
 Mount Savage,  
     sections of Bakerstown coal near,  
         Pittsburg coal near, 379.  
         Redstone coal near, 399.  
         Upper Freeport coal near, 341.  
 Mount Savage or Upper Mercer coal, described, 296, 324.  
 Mt. Savage coal discussed, 319, 320, 453, 478.  
     sections of, 326, 327, 453, 478.  
 Mt. Savage fire-clay, 296, 325.  
 Mt. Savage Iron Co., 518.  
 Mt. Savage plane, section of Bakerstown coal near, 351.  
 Mt. Zion Church,  
     section of Friendsville coal near, 448.  
     Lower Kittanning coal near, 416.  
 Mowbray, John, section of Brush Creek on property of, 347.  
 Mullen, Joseph, 175, 178.  
 Musselman farm, 514.
- N**
- Naming of coal seams, 321.  
 National Coal Co., 521.  
 National Road, 139, 253.  
     improvement of, 162, 163.  
     section of Bakerstown coal near, 469.  
     Grantsville coal near, 465.  
     Maynadler coal near, 474.  
 Naval Observatory, 28.  
 Neat, Noah, section of Bakerstown coal in fire-coal opening of, 357.  
 Neff, Wm., section of Brush Creek coal on property of, 349.  
 Neighborhood Improvement Club, 146.  
 Nethken, F. R., section of Upper Freeport coal in mine of, 492, 493.  
 Newark, Del., magnetic station at, 61.  
 Newberry, J. S., 240.  
 New Central Coal Co., 591.  
     sections of Lonaconing coal on property of, 370, 371.  
     Little Pittsburg coal on property of, 376.  
     Pittsburg coal on property of, 388.  
     Upper Sewickley coal on property of, 401.  
     Waynesburg coal on property of, 405.  
 New Detmold mine, 586.  
     section of Pittsburg coal in, 389.  
 New Germany, horizontal intensity at, 87.  
     magnetic inclination at, 77.  
     magnetic station at, 55.  
 New York Mining Co., 516, 573, 521.  
     section of Pittsburg coal on property of, 381.

- Niles Mill,  
sections of Mahoning coal near, 508.  
Upper Freeport coal near, 505.
- North Potomac syncline described, 261.
- Northern Appalachian coal field, 234.
- Northern Appalachian field, production of coal in, 234, 235, 236, 237.
- Nova Scotia, Carboniferous strata of, 226.
- Noy and Al. Frazee's mine, section of Friendsville coal in, 511.
- Nydecker Run, section of Upper Freeport coal on, 435.
- O**
- Oakland, horizontal intensity at, 85.  
magnetic inclination at, 75.  
magnetic station at, 55.  
sections of Lower Kittanning coal near, 481, 482.  
Lower Freeport coal near, 489.  
Upper Freeport coal near, 492, 494.
- Oakland-Mt. Lake Park road, improvements to, 172.
- Oakland Coal and Coke Co., section of Lower Kittanning coal in mine of, 483.
- Oak Shoals, section of Lower Kittanning coal in mine near, 482.
- Ocean City, horizontal intensity at, 85.  
magnetic inclination at, 75.  
magnetic station at, 55.
- Ocean mines, 561-571.
- Ocean Steam Coal Co., 518.
- Offut's mine, section of Lower Kittanning coal in, 484.
- O'Harra, C. C., 261, 262.
- O'Haver, Jos., section of Upper Freeport coal in mine of, 435.
- Old Frederick road, improvements to, 176.
- Old Union No. 2, section of Bakerstown coal at, 351.
- Orcendorff, John, section of Brush Creek coal on property of, 346.
- Origin of coal, 224.
- Oxford, horizontal intensity at, 86.  
magnetic inclination at, 76.  
magnetic station at, 55.
- P**
- Pacific coast, development of coal on, 224.
- Paleozoic periods, history of, 274.
- Parker coal discussed, 319, 320, 331, 332, 455.
- Parker Vein Coal Co., 518.
- Park Heights avenue, improvement of, 168, 170.
- Parkton, horizontal intensity at, 87.  
magnetic inclination at, 77.  
magnetic station at, 55.
- Parrett, J. H., 591.
- Parsonsborg, horizontal intensity at, 85.  
magnetic inclination at, 75.  
magnetic station at, 55.
- Pattison, G. C., mines of, 606.  
section of Bakerstown coal in, 440.
- Patton mine, 586.
- Paving brick tests, 188, 189, 190.
- Paw Paw, W. Va., horizontal intensity at, 87.  
magnetic inclination at, 77.  
magnetic station at, 63.
- Peeble, Thos., section of Lonaconing coal in out-crop near, 371.
- Pekin,  
sections of Bakerstown coal near, 358.  
Little Pittsburg coal near, 377.  
Pittsburg coal near, 391, 392.
- Penn mine, 603.
- Penniman, W. B. D., 219, 619.
- Pennsylvanian period, 278.
- Permian period, 289.
- Percy tract, 521.
- Phillippi, W. Va., magnetic station at, 64.
- Phoenix,  
section of Bakerstown coal near, 363, 365.  
Brush Creek coal near, 349.  
Pittsburg coal near, 395.  
Upper Freeport coal near, 343.
- Phoenix and Georges Creek Mining Co., 600.  
section of Bakerstown coal on property of, 365.
- Phoenix mine, 600.  
section of Pittsburg coal in, 395.  
Lower Kittanning coal on, 339.  
Quakertown coal near, 325.
- Pickell mine, 602.
- Pickell tract, section of Pittsburg coal on, 390.
- Pickens, W. Va., magnetic station at, 64.
- Piedmont,  
section of Lower Sharon coal near, 323.  
Upper Sharon coal near, 324.
- Piedmont coal, 530.
- Piedmont Coal and Iron Co., 521.
- Piedmont Mining Co., 604.
- Piedmont-Cumberland Coal Co., 601.  
section of Lower Kittanning coal on property of, 337, 338.
- Piedmont and Georges Creek Coal Co., 598.  
section in mine of, 333.  
Bakerstown coal near, 368.

- Piedmont and Georges Creek Coal Co.,  
 section in mine of,  
 Brush Creek coal near, 350.  
 "Split-Six" coal in mine of, 333.  
 Upper Sewickley coal on property  
 of, 400.
- Pierce, John T., 556.
- Pincher's opening in Bakerstown coal,  
 352.
- Piney Mountain, section of Brookville  
 coal on, 329.
- Piney Run,  
 section of Brookville coal on, 454.  
 Clarion coal on, 455.  
 Lower Kittanning coal on, 457.  
 Mt. Savage coal on, 453.  
 "Pine Hill mine," 581.
- Pin-puller used in Maryland, 554.
- Pittsburg coal discussed, 255, 310, 319,  
 320, 380, 529, 530.  
 sections of, 379-398, 450, 451.  
 thickness of, 531.
- Platt coal, 306.
- Platt, Franklin, 301.
- Pleasant Valley Run, section of Friends-  
 ville coal on, 476.
- Pocomoke City, horizontal intensity at,  
 85.  
 magnetic inclination at, 75.  
 magnetic station at, 56.
- Pocono epoch, 275.
- Pocono formation, 318.
- Point of Rocks, horizontal intensity at,  
 85.  
 magnetic inclination at, 75.  
 magnetic station at, 56.
- Pompey Smash, 514.
- Position of beds in Maryland Coal  
 Measures, 243.
- Potomac Basin discussed, 317, 407.  
 Conemaugh coals of, 438.  
 Monongahela coals of, 449.
- Potomac Coal Co., 521, 573, 576.  
 section of Franklin coal on property  
 of, 374.  
 Little Pittsburg coal on property  
 of, 377.
- Potomac meridian line, magnetic sta-  
 tions along, 60, 61.
- Potomac mine, 576.  
 section of Bakerstown coal in, 361.  
 Pittsburg coal in, 394.
- Pottsville coals of Castleman Basin,  
 452.  
 Georges Creek Basin, 323.  
 Lower Youghiogheny Basin, 496.  
 Upper Potomac Basin, 408.  
 Upper Youghiogheny Basin discussed,  
 477.
- Pottsville epoch, 279.
- Pottsville formation discussed, 243, 244,  
 319.  
 columnar sections of, 293.  
 composition and relations of, 293.  
 sections in, 245-247.
- Preface, 19.
- Pre-Quaternary periods, 289.
- Preston Coal and Lumber Co.,  
 section of Clarion coal on property of,  
 479.  
 Lower Kittanning coal in mine of,  
 488, 489.
- Prices for coal in early days, 516.
- Prices for mining coal, 559.
- Princess Anne, horizontal intensity at,  
 85.  
 magnetic inclination at, 75.  
 magnetic station at, 56.
- Prince Frederick, magnetic inclination  
 at, 75.  
 magnetic station at, 56.  
 horizontal intensity at, 85.
- Prince George's county, road expendi-  
 tures in, 157.  
 road improvements in, 180.
- Production and distribution of coal, 228.
- Production of coal in Northern Appa-  
 lachian field, table, 234, 235, 236,  
 237.
- Production of coal in United States, 232.
- Production of coal in the world, 229.
- Props in coal mines, 534.
- Proximate analyses, tables of, 628.
- Pumping shaft, 543.  
 section of Dunkard formation near,  
 258.  
 Monongahela formation in, 255.  
 Uniontown coal in, 404.  
 Washington coal near, 407.
- "Punching machine," 540.
- Putnam, G. R., 79.

## Q

- Quakertown coal discussed, 244, 295,  
 319, 320, 324.  
 section of, 325.  
 section near Old Phoenix Mine, 325.  
 section near Westernport, 325.
- Quaternary Period, 290.
- Queen Anne's county, road expenditures  
 in, 157.  
 road improvements in, 184.
- Queen, Samuel, 182.
- Quince Orchard, horizontal intensity at,  
 88.  
 magnetic inclination at, 78.  
 magnetic station at, 56.

## R

"Railroad seam," 324, 325, 332, 410.  
 Randolph, B. S., 219, 513, 569.  
 Rankin, Robt. G., 517.  
 Rattler tests, 190, 191.  
 Redland, horizontal intensity at, 88.  
   magnetic inclination at, 78.  
   magnetic station at, 56.  
 Redstone coal, 256, 310, 319, 320.  
   section of, 399.  
 Redstone limestone, 310.  
 Reisterstown, horizontal intensity at,  
   87.  
   magnetic inclination at, 77.  
   magnetic station at, 56.  
 Remsen, Ira, v.  
 "Repeat stations," 26.  
 Richmond basin, coal of, 224.  
 Richmond, Va., magnetic station at, 62.  
 Ridgeley Hill, section of Grantsville coal  
   on, 466.  
 Ridgely, horizontal intensity at, 85.  
   magnetic inclination at, 75.  
   magnetic station at, 56.  
 Ridgley's mine, sections of Grantsville  
   coal in, 466, 467.  
 Riggs road, improvements to, 181.  
 Rising Sun, horizontal intensity at, 87.  
   magnetic inclination at, 77.  
   magnetic station at, 56.  
 Rising Sun-Farmington road, improve-  
   ments to, 170.  
 River road, improvements to, 176.  
 Road accounts, 151.  
   administration, 148.  
   appropriations, 150.  
   districts, 150.  
   engineer, 149.  
   expenditures, 153-155.  
   machinery, 152.  
   mileage in Maryland by counties, 153.  
   statistics, 152.  
   supervisors, 150.  
 Roaring Creek sandstone, 300.  
 Roaring Hill, 139.  
 Robertson, Albert, section of Upper  
   Freeport coal in mine of, 506.  
 Rockburn Branch road, improvements  
   to, 179.  
 Rock Church, section of Little Pittsburg  
   coal near, 378.  
 Rockville, magnetic inclination at, 76.  
   magnetic station at, 56.  
 Rogers, H. D., 297, 309, 314.  
 Roman Nose,  
   section of Lower Kittanning coal on  
   west side of, 481.  
   Upper Freeport coal near, 492.  
 Roof coal, 534.

Room and pillar system, 532.  
 Ross, Samuel, section of Bakerstown coal  
   in fire-coal opening of, 361.  
 Round Hill, Va., magnetic station at, 62.  
 Rumbaugh, Harry, sections of Little  
   Pittsburg coal in mine of, 512.  
 Russell, Archie, section of Bakerstown  
   coal on farm of, 356.  
 Rutledge, J. J., 219, 317.

## S

St. Mary's county, road expenditures in,  
   157.  
   road improvements in, 186.  
 Saltsburg, horizontal intensity at, 85.  
   magnetic inclination at, 75.  
   magnetic station at, 57.  
 Saltsburg sandstone, 252, 305.  
 Salt Block Mountain, section of Bakers-  
   town coal on, 470.  
 "Sandrock" coal discussed, 491, 504.  
 Sand Run, section of Lower Kittanning  
   coal on, 424.  
 Sang Run, section of Lower Kittanning  
   coal near, 509, 503.  
 Savage, Grant, section of Upper Free-  
   port coal in mine of, 507.  
 Savage Mountain Fire Brick Works, sec-  
   tion of Mt. Savage coal at, 327.  
 Scarborough, magnetic inclination at, 76.  
   magnetic station at, 57.  
 Schaldt, John, 106.  
 Schill,  
   section of Lower Kittanning coal near,  
   422.  
   Upper Freeport coal near, 435.  
 Seaford, Del., magnetic station at, 61.  
 Section of Allegheny formation in Big  
   Savage fire-clay tunnel, 250.  
   Allegheny formation at Harrison, W.  
   Va., 249.  
   Allegheny formation at Borehole No.  
   1, Henry, 248.  
   Allegheny formation at Jennings Mill,  
   250.  
 Bakerstown coal, 350-368, 440-448,  
   469-474, 495, 510.  
 Brookville coal, 328-331, 454.  
 Brush Creek coal, 345-350, 439, 440,  
   463, 509.  
 Clarion coal, 332, 410-412, 455, 456,  
   479.  
 Conemaugh formation, 251-254.  
 Dunkard formation, 258.  
 Franklin coal, 372-376, 511.  
 Friendsville coal, 369, 448, 449, 476,  
   511.  
 Grantsville coal, 464-468.  
 Little Pittsburg coal, 376, 512.

- Section of Allegheny formation in Big  
Savage fire-clay tunnel, 250.
- Lonaconing coal, 369-371.
- Lower Freeport coal, 340, 459, 460,  
489, 490, 504.
- Lower and Middle Kittanning coal,  
413-429.
- Lower Kittanning coal, 334-340, 457,  
458, 480-489, 497-503.
- Lower Sewickley coal, 399.
- Lower Sharon coal, 323.
- Mahoning coals, 344-345, 439, 462,  
508.
- Maynadier coal, 474, 475.
- Monongahela formation at Borden  
shaft, 255.
- Monongahela formation near Frost-  
burg, 255.
- Monongahela formation near Jackson  
mine at Lonaconing, 257.
- Monongahela formation at Koontz,  
256.
- Monongahela formation at Lonacon-  
ing, 256.
- Mt. Savage coal, 326, 327, 453, 478.
- Pittsburg coal, 379-398.
- Pottsville formation in, 245-247.
- Quakertown coal, 325.
- Redstone coal, 399.
- "Split-six" coal, 333, 497.
- Upper Freeport coal, 341-344, 431-  
438, 461, 491-493, 505-507.
- Upper Kittanning coal, 430.
- Upper Sewickley coal, 400-404.
- Upper Sharon coal, 324.
- Uniontown coal, 404.
- Washington coal, 407.
- Waynesburg coal, 405.
- Section showing Maryland coal measures,  
243.
- Selbysport,  
section of Brush Creek coal near, 509.  
Mahoning coal at, 508.
- Seminary avenue, improvement of, 167.
- Seneca, horizontal intensity at, 86.  
magnetic inclination at, 78.  
magnetic inclination at, 76.  
magnetic station at, 57.
- Sewickley limestone, 311.
- Sewickley sandstone, 311.
- Shamrock mine, 604.
- Sharon coal discussed, 244, 295, 319,  
320, 323.
- Sharon sandstone, described, 295.
- Sharpless mine, section of Bakerstown  
coal in, 442.
- Shaw, A. B.,  
section of Bakerstown coal in opening  
of, 359.
- Shaw,  
section of Bakerstown coal near, 443.  
Lower Kittanning coal near, 416.  
Pittsburg coal near, 450.
- Sherwood bridge, 169.
- Short Gap Run, section of Lower Free-  
port coal near, 340, 342.
- Signals in coal mines, 552.
- Silvester, R. W., v.
- Sinclair, C. H., 141.
- Sine, W. T., section of Upper Freeport  
coal in mine of, 491.
- "Six-foot" coal discussed, 334, 413.
- Sixth District Road League, 146.
- Skipper, Thomas, section of Lower Kit-  
tanning coal in mine of, 480.
- Slag road, estimates on, 186.
- Slips, danger from, 534.
- Small vein coals discussed, 559.
- Smith, John, section of Upper Freeport  
coal on property of, 341.
- Smith, R. A.,  
section of Lower Kittanning coal in  
mine of, 419.  
Upper Freeport coal in mine of, 433.
- Smith, S. P., 521.
- Snaggy Mountain, horizontal intensity  
at, 87.  
magnetic station at, 60.  
section of Lower Kittanning coal on,  
481.
- Snow Hill, horizontal intensity at, 85.  
magnetic inclination at, 75.  
magnetic station at, 57.
- "Soldiers Lots," 513.
- Somerset county, road expenditures in,  
158.
- Special road improvement, 162.
- Specifications used by Highway Division,  
161, 203.
- Spiker Run, section of Bakerstown coal  
on, 469.
- Spint coal, 240.
- "Split-six" seam, 248, 299, 319, 320,  
333, 496.  
sections of, 333, 497.
- Stabler, magnetic inclination at, 76.  
magnetic station at, 58.
- Stafford mine, 593.
- Stanton, W., section of Bakerstown coal  
in mine of, 469.
- Stanton mine, section of Grantsville coal  
in, 466.
- Steele, Wm., section of Lower Kittanning  
coal in mine of, 497.
- Stevenson, J. J., 294, 305, 314.
- Stevenson Station road, improvement of,  
166.
- Stockton, N. Allen, 219, 529.

- Stottlemeyer's mine in Friendsville coal, 448.
- Stoyer, George, section of Bakerstown coal on property of, 446.
- Stoyer,  
 section of Bakerstown coal near, 446.  
 Lower Kittanning coal near, 423.
- Stoyer Run Coal Co., 611.
- Stratigraphy of Maryland Coal District, 241.
- Strikes in coal region, 524.
- Structure of Maryland Coal Measures, 259.
- Stupart, R. F., 28.
- Sulphur, definition of, 621.  
 determination of, 622.
- Swallow Falls,  
 section of Bakerstown coal near, 495.  
 Lower Kittanning coal near, 480.  
 Mt. Savage coal near, 478.  
 Pottsville formation at, 246.  
 Upper Freeport coal near, 491.
- Swanton, horizontal intensity at, 87.  
 magnetic inclination at, 77.  
 magnetic station at, 58.  
 section of Bakerstown near, 442.  
 Upper Kittanning near, 430.
- Swanton mine, 598.
- Swanton Mining Co., 521.
- Swanton plane, 251.
- Sykesville, horizontal intensity at, 87.  
 magnetic inclination at, 77.  
 magnetic station at, 58.  
 road improvements to, 177.
- Syncline, Castelman, 265.
- Systems of mining, 532.
- T**
- Table showing magnetic elements and components in Maryland, 91-95.  
 showing proximate analyses of coal, 628.  
 showing production of coal in Northern Appalachian field, 234-237.  
 showing world's production of coal, 229.
- Tacoma mine, 598.
- Taff, J. A., 259, 261, 262.
- Tali-rope system of haulage, 542.
- Talbot county, road expenditures in, 158.
- Taneytown, horizontal intensity at, 87.  
 magnetic inclination at, 77.  
 magnetic station at, 58.
- Tasker corner,  
 section of Bakerstown coal near, 445.  
 Lower Kittanning coal near, 421.
- Tasker's,  
 section of Bakerstown coal at, 443.  
 Brush Creek coal at, 439.  
 Mahoning coal at, 439.  
 Upper Freeport coal at, 431.  
 Upper Kittanning in, 430.
- Taylor's Hill, horizontal intensity at, 87.  
 magnetic inclination at, 77.  
 magnetic station on, 61.
- T B road, improvements to, 182.
- Tests on concrete bars, 194.  
 of macadam materials, 187.  
 paving brick, 190.  
 showing wear of brick, 190.  
 on wearing quality of stone and brick, 199.
- Third District Road League, 146.
- Thomas,  
 section of Lower Kittanning coal at, 428, 429.  
 Upper Freeport coal near, 437.
- Thomas coal discussed, 319, 320, 341, 432.  
 sections of, 437, 438.
- Thomas Run, horizontal intensity at, 86.  
 magnetic inclination at, 76.  
 magnetic station at, 58.
- "Three-foot" coal discussed, 305, 341, 432.
- Three-fork creek,  
 section of Clarion coal on, 411.  
 Lower Kittanning coal on, 417.  
 Bakerstown coal on, 441.
- Tiehnel, Geo. W., section of Bakerstown coal in mine of, 441.
- Tilghman's Island, horizontal intensity at, 86.  
 magnetic inclination at, 76.  
 magnetic station at, 58.
- Tipple commonly used in Georges Creek region, 553.
- Tittmann, O. H., 25.
- Tobacco House Hill road, improvements to, 179.
- Tolchester, horizontal intensity at, 86.  
 magnetic inclination at, 76.  
 magnetic station at, 58.
- Towson, horizontal intensity at, 86.  
 magnetic inclination at, 76.  
 magnetic station at, 58.
- Transportation of coal, early methods, 514.
- Trimble farm,  
 section of Franklin coal on, 372.  
 Lonaconing coal on, 369, 370.
- Trotters Run, section of Bakerstown coal near, 351.



Trout Run, section of Upper Freeport coal on, 435.  
 "Two-foot" vein, 325.  
 Tyson, P. T., Jr., 256, 258.  
 Tyson coal, 311, 319, 320, 399.

## U

Umbel, Wm., section of Upper Freeport coal in mine of, 506.  
 U. S. Coast and Geodetic Survey, 104.  
   magnetic stations of, 61.  
 U. S. Geological Survey, 105.  
 United States, production of coal in, 232.  
 Unlty, horizontal intensity at, 86.  
   magnetic inclination at, 76.  
   magnetic station at, 59.  
 Union Mining Co., 573.  
   section of Mahoning coal on property of, 344.  
     Mt. Savage coal in tunnel of, 326.  
     Pittsburg coal in mine of, 394.  
 Unlontown coal, 256, 312, 404.  
   sections in, 404.  
 Unlontown limestone, 311.  
 Unlontown sandstone, 312.  
 Upper Barren Coal Measures, 313.  
 Upper Cambridge limestone, 305.  
 Upper Connoquenessing sandstone described, 295, 325.  
 Upper Freeport coal, 300, 319, 320, 322, 341, 432, 460, 491, 504, 505.  
   sections of 341-344, 431-438, 461, 491-494, 505-507.  
 Upper Freeport limestone, 300.  
 Upper Freeport or Roaring Creek sandstone, 300.  
 Upper Kittanning coal discussed, 248, 299, 319, 320, 339.  
   sections of, 430.  
 Upper Mercer coal discussed, 324, 325, 478.  
 Upper Mahoning sandstone, 303.  
 Upper Marlboro, horizontal intensity at, 85.  
   magnetic inclination at, 75.  
   magnetic station at, 59.  
 Upper Potomac Basin, 407.  
 Upper Potomac Mining Co., 610.  
 Upper Productive Measures, 379.  
 Upper Sewickley coal, 256, 311, 319, 320, 399.  
   sections of, 400-404.  
 Upper Sewickley mines of Consolidation Coal Co., 572.  
 Upper Sharon coal, 319, 320, 324.  
   sections near Westport, 324.  
 Upper Sykesville road, improvements to, 177.

Upper Youghiogheny Basin discussed, 317, 477.  
   Allegheny coals of, 479.  
   Conemaugh coals of, 498.  
   Pottsville coals of, 477.  
 Upper Youghiogheny syncline, 267.  
 Upper Washington limestone, 314.

## V

Vale Summit, opening at, 514.  
 Vanpost limestone described, 298.  
 Vansville Farmer's Club, 146.  
 Van Werth's mine, section of Lower Kittanning coal in, 485.  
 Ventilation in coal mines, 545.  
 Vertical intensity, diurnal variation of, 68, 69.  
 Virginia, magnetic stations in, 61, 62.  
 Volatile Carbon, definition of, 621.  
   determination of, 621.  
 Von Boyneburk's opening in Bakerstown coal, 366.

## W

Walker, W. Irving, 184.  
 Wallis, W. F., 98.  
 Wallman, section of Lower Kittanning coal near, 423.  
 Warfield, Edwin, v, ix.  
 Warnick's, section of Clarion coal near, 410.  
 Waring, horizontal intensity at, 88.  
   magnetic declination at, 44.  
   magnetic inclination at, 78.  
   magnetic station at, 59.  
 Warrior Run, section of Brookville coal on, 330.  
 Washington and Baltimore road, improvements to, 176, 182.  
 Washington coal, 314, 319, 320.  
   section of, 407, 517.  
 Washington mines, 598.  
 "Washington county group," 313.  
 Washington county, road expenditures in, 158.  
 Watson-Loy Coal Co., 607.  
 Waynesburg "A" coal, 314, 319, 320.  
 Waynesburg coal discussed, 256, 312, 319, 320, 404.  
   sections of, 405, 406.  
 Waynesburg limestone, 312.  
 Waynesburg sandstone, 314.  
 Wearing test of stone and brick, 199.  
 Webb, horizontal intensity at, 86.  
   magnetic inclination at, 76.  
   magnetic station at, 59.  
 Wellersburg syncline, 261.  
 West Virginia, magnetic stations in, 63.



- Westernport, horizontal intensity at, 86.  
 magnetic inclination at, 76.  
 magnetic station at, 59.  
 sections of Bakerstown coal near, 364,  
 367.  
   Clarion coal near, 332.  
   Lower Sharon coal near, 323.  
   Pittsburg coal near, 397, 398.  
   Pottsville formation near, 245.  
   Quakertown coal near, 325.  
   Upper Sharon coal near, 324.  
 Westernport coal, 319, 320, 325.  
 Westminster, horizontal intensity at, 85.  
 magnetic inclination at, 75.  
 magnetic station at, 59.  
 Weston, W. Va., magnetic station at, 64.  
 White, David, 279, 294, 295.  
 White, I. C., 286, 295, 300, 303, 304,  
 308, 310, 311, 315, 408, 478.  
 "White Rock" coal discussed, 497.  
 White Rock Run, section of "Split-six"  
 coal on, 497.  
 White Rock mine, section of Lower Kit-  
 tanning coal in, 500, 503.  
 Wicomico county, road expenditures in,  
 158.  
 Wild coal, 534.  
 Willey, John, section of Friendsville coal  
 in mine of, 476.  
 Willis, Bailey, 259, 275.  
 Wilson, E.,  
   section of Bakerstown coal in mine  
   of, 445.  
 Wilson,  
   section of Lower Kittanning coal near,  
   424.  
   Upper Freeport coal near, 436.  
 Wilson, H. M., 120.  
 Wilson, W. B., 525.  
 Windom, section of Lower Kittanning  
 coal near, 413, 414.  
 Winter opening in Brookville coal sec-  
 tion, 329.  
 Wire rope haulage, 542.  
 Withers Mining Co., 518, 521.  
   section of Pittsburg coal in opening  
   of, 380.  
 Withers tract, section of Upper Scwick-  
 ley coal on, 400.  
 Witmer's tramroad, section of Lower  
 Kittanning near, 423.  
 Woodstock, Va., horizontal intensity at,  
 86.  
   magnetic station at, 59, 62.  
 Worcester county, road expenditures in,  
 158.  
 World's production of coal, 229.  
 Wright farm, 521.
- Y
- Yommer, Henry, section of Lower Free-  
 port coal in opening of, 459.  
 Yommer, L., section of Maynadler coal  
 in opening of, 475.  
 Youghiogheny River,  
   section of Lower Kittanning coal on,  
   484.  
   Upper Freeport coal on, 491, 493.